

DIM Design & Installation Manual

Largo | Carat, Avera, Vintago, Reflex, Vintago-Reflex, Nobilis, Terra, Planea, Zenor



General information, Program		Remarks, system, validity, ordering material, rain screen cladding	3
	Panel sizes	Overview panel sizes	4
		Application cutting	5
	Reflex, Vintago,	Appearance Reflex, Vintago and Vintago - Reflex, arrows to rear face	6
	Vintago - Reflex	Ordering material, Software support, Positioning, Cutting from CAD	6-7
	Adhesive	Adhesive application	7
	Bending radius	Portrait / Landscape	8
	Accessories	Fasteners	9
		Joint material	10
		Terminology	11
Design	General remarks	Corner zone, Application, Windload	12
		Insulation, Rear ventilation, Open joints	12
		Ventilation openings, building dilatation	12
		Panel support, Compatibility, Sub-frame	13-14
		Distances to panel edge, joints, fixed and sliding points	15
	Metal panel support	Aluminum, steel sub-frame	16-17
		Drilling and riveting, fixed point, sliding point, fastener distances	18
		Windload guidelines	19-22
		Single span panel	23
		Largo portrait/landscape	24-26
		Fastening layout stripes	27-28
	Details	Outer corner, Inner corner, Window jamb, window sill	29-31
		Window head, bottom detail, coping detail	32-34
	Timber panel supports	Distances to panel edge, panel joints	35
		Timber quality, screws, ventilation cavity	36
		Horizontal section, vertical joints at windows, fastener distances	37-38
		Windload guidelines	39-42
Single span panels, Installation		43	
Installation		Largo portrait/landscape	44
		Fastening layout stripes	45-46
	Details	Outer corner, Inner corner, Window jamb, window sill	47-49
		Window head, bottom detail, coping detail	50-52
	Storage on site	On site storage, Guideline, Stacking	53
	Cutting, Tools	Fabrication, Cut outs, Sealer, tools	54
	Cleaning	Cleaning procedures, Masking tape	55

Remarks

This DIM (Design + Installation Manual) provides technical information regarding design and installation. Refer to area manager and local distributor for further information such as:

- Terms of delivery
- Pricing
- Products and colors
- Lead time, etc.

More general information available on swisspearl.com

8867 Niederurnen, Switzerland
+41 55 617 11 60
info@swisspearl.com

Validity of DIM

Please consult your local distributor and or the Technical Advisor prior to the commencement of shop drawings or installation for the most current DIM guide. The current DIM can always be found at swisspearl.com. All previous DIM guides should be disregarded and are no longer valid.

Product warranty

Warranty conditions are available on request from your local Swisspearl office or dealer.

Maritime conditions

Maritime conditions call the use for stainless steel rivets. Those may be used on steel or anodized aluminum sub frame. Maritime conditions are considered 50m to 1km (0.03 to 0.6 miles) from the sea. Material specification for sub frame, fasteners and accessories to cater for maritime conditions according to local standards.

Advantages of fiber cement products

- Maximum protection against weather
- Excellent longevity
- Easy installation in any climate
- Almost no maintenance required
- Proven details
- No cracks, paint or sealant problems
- High sustainability
- Non combustible

Project specific ordering

Subtle visual differences may occur between product batches. Therefore we recommend ordering by job or specific elevation if ordering in phases.

Disclaimer

The information and recommendations contained in this Design & Installation Manual ("DIM") are offered as a service to architects, constructors, installer and other persons involved with our products and are not intended to relieve them from their own responsibility. The information and recommendations provided herein are believed by Swisspearl Group to be accurate at the time of preparation of this DIM, or obtained from sources believed to be generally reliable. Swisspearl Group makes no warranty concerning the accuracy of the content of this DIM and shall not be liable for claims relating to any use regardless of whether it is claimed that the information or recommendations are inaccurate, incomplete, or otherwise misleading. The information and recommendations herein are intended to be used with the judgment and experience of professional personnel competent to evaluate the significance and limitations of the material contained. Swisspearl Group expressly disclaims any guarantees or warranties, expressed or implied, for anything described or illustrated herein and assumes no responsibility or liability for damages of any kind, including – without limitation – bodily harm, injury or damage to property inferred from this DIM or the use of the materials described herein.

Overview panel sizes

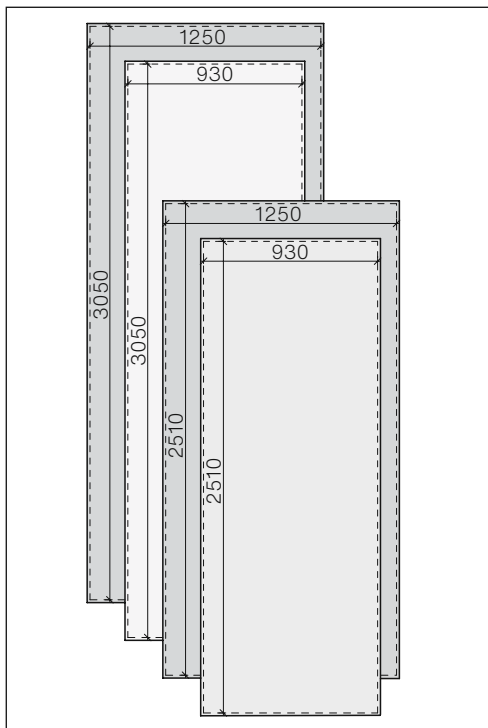

8 mm & 12 mm thick panels – max. net panel sizes

Overview

Largo		Nobilis Terra Planea	Zenor	Carat Reflex Vintago Vintago - Reflex Avera	Carat Reflex
Thickness	mm	8/12	8	8	12
Weight	ca.kg/m ²	15.7/24.6	15.7	15.7	24.6
Format	mm				
Untrimmed panels	max. net panel sizes				
3070×1270	3050×1250	■*	■	■	■
2530×1270	2510×1250	■	■	■	■
3070×950	3050×930	■			
2530×950	2510×930	■			

* Nobilis and Terra 12 mm panels are only available in size 2510 × 1250 mm.

Product data

- Density > 1.75g/cm³
- Modulus of elasticity ca. 15'000 MPa
- Design resistance for bending ca. 8.0 MPa
- Thermal expansion coefficient 0.01 mm / m / °K
- Fire classification according to NFPA 285 EN 13 501-1 & A2-s1, d0
- Frostresistance and durability under EN 12467
- Thermal range – 40°C to + 80°C

HR coating

Special coating with increased scratch and UV resistance that allows removal of graffiti using Acetone. Availability as per Program and Colors.

F-coating for facade

For inclined cladding, panels with F-coating cater for increased exposure to weathering. It is opaque and matched to standard finishes, and has higher UV resistance.

R-coating for roof

Roofing panels must have minimum fall of 6° (10.5%). R-coating is opaque and matched to standard finishes, and has higher UV resistance. The panels in the color ranges Amber and Onyx are supplied with standard grey panel core.

Application

Largo panels can be attached to vertical timber or metal profiles. Suitable for new facades or existing cladding renovations.

Untrimmed full size panels

Untrimmed panels will only be provided to approved fabricators. Untrimmed Largo panels must be trimmed 10mm on all four sides.

Signage, light fittings, etc.

Provide structural attachment points behind the panel as required. Leave generally min. 6 mm (¼") free gap between panel edge and installation – so as not to constraint the panel movement.

Sealed cut edges

All panel edges cut on site or at fabricators workshop must be sealed by LUKO sealer, provided by Swisspearl.

Installation Reflex, Vintago, Vintago - Reflex

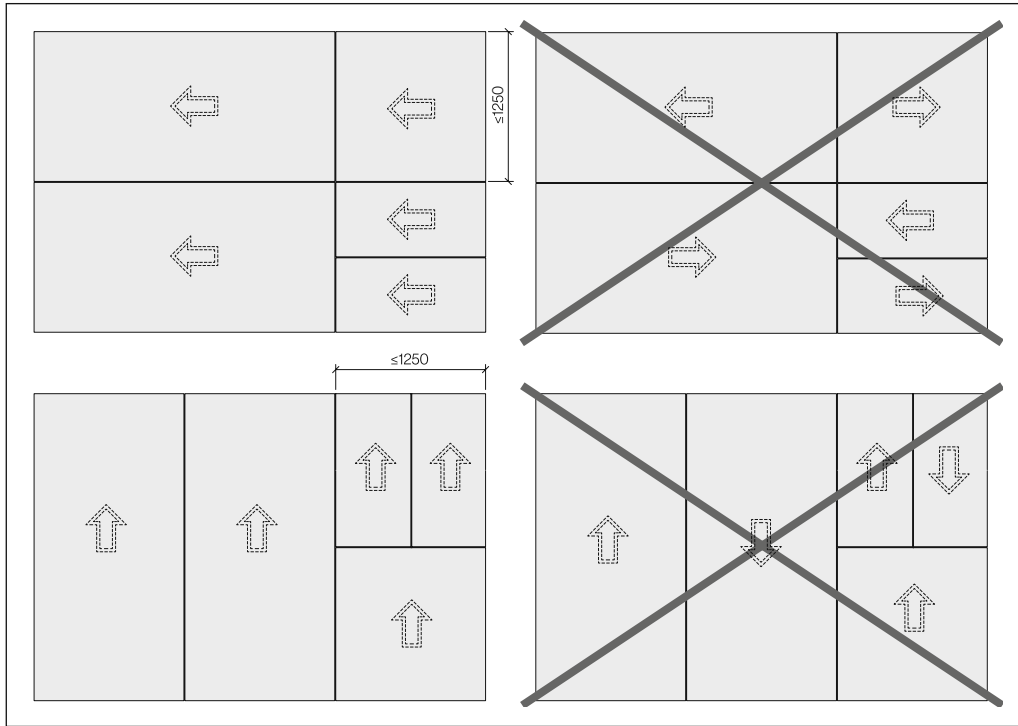

When installed, all the arrows on the backside of the Reflex, Vintago and Vintago - Reflex panels must point in the same direction.

Landscape orientation
All arrows to the left

Portrait orientation
All arrows up

Cutting CAD drawing
 Regarding panel fabrication at the factory based upon CAD drawings as for odd panel shapes, perforations etc.: Arrows must be indicated on the drawings to all panels. Panels always shown as seen on building elevation (finished face).

Panels are shown as on building elevation (finished face).

Adhesive application

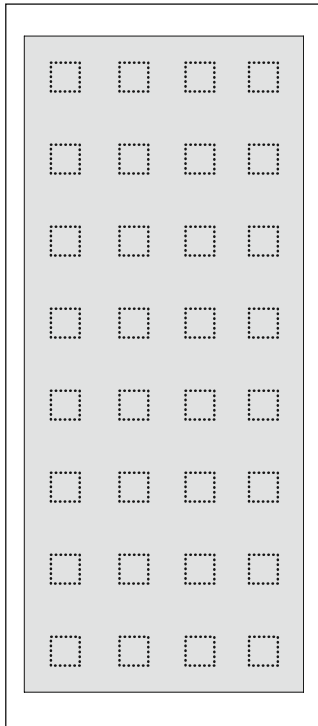

Adhesive technology

Specially ordered ARSB panels are signified by printed squares on the backside of the panel. Please consult with your adhesive manufacture prior to installation. Zenor panels are available for an adhesive application with the exception of white cement panels, Zenor 11006, 11115, 15015, 23048, 23057, 41054 and 41055 which are only available for face fastened system.

General requirements

Glue manufacturer's instructions for use must be strictly followed regarding all aspects, including:

- Cleanliness of panels and support profiles
- Panel and air temperature
- Air moisture content
- Etc.

Support profiles

- For exterior application the panels may be glued to aluminium supports only.
- Sub framing to be approved by glue manufacturer prior to stating the installation.

Panel ordering

Panels ordered for adhesive application are called ARSB and are available upon request at time of order. Standard Swisspearl panels cannot be used for adhesive application.

Warranty

Panel manufacturer provides functional warranty for the panels only. Warranty for the attachment of the panels to be obtained by glue manufacturer.

Largo 8 mm portrait

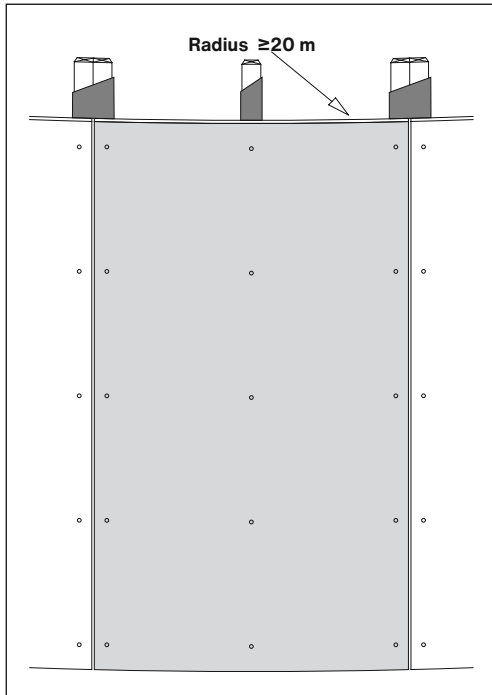

Portrait panels, attached to vertical supports.
Minimum radius = 20 m.
Fix the battens with 2 screws per fixing point.

Largo 8 mm landscape

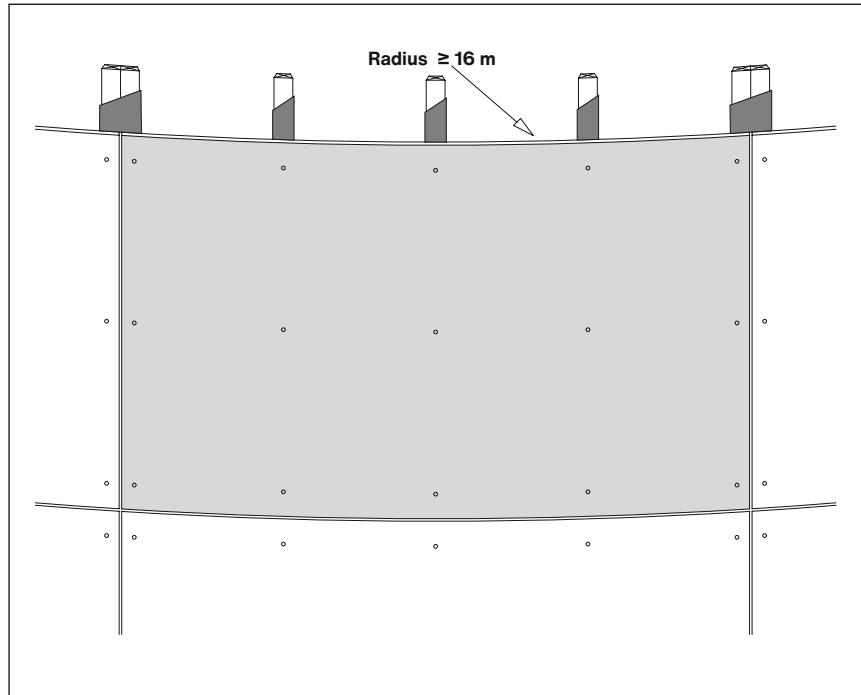

Landscape panels, attached to vertical supports at max. 600 mm centers.
Minimum radius = 16 m. Fix the battens with 2 screws per fixing point.

Fasteners

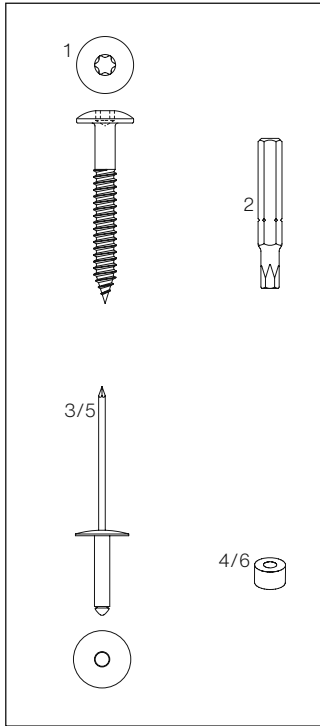

To timber battens

1. Swisspearl Screw, inox, saucer head Ø 12 mm, T20 drive, blank or powder coated (Red Horse)
 - 4.8×30 mm
 - 4.8×38 mm
 - 4.8×44 mm
 - 4.8×60 mm

Screws (former Cembrit), inox, saucer head Ø 12 mm, T20 drive, blank or powder coated

- 4.5×30 mm SCR-W 4.5×30 mm A2
- 4.5×36 mm SCR-W 4.5×36 mm A2
- 4.5×41 mm SCR-W 4.5×41 mm A2
- 4.9×38 mm SCR-W 4.5×38 mm A2 DC
- 4.8×40 mm SCR-W 4.5×40 mm A4

2. Torx bit T 20 W

To aluminium profiles

3. Swisspearl aluminium rivet head Ø 15 mm, blank or powder coated (SFS and MBE)
 - 4.0×18-K15, 8-13 mm grip range
 - 4.0×24-K15, 13-18 mm grip range
 - 4.0×30-K15, 18-23 mm grip range
 Rivets (former Cembrit), head Ø14 mm, RIV-A EPDM washer 4.0×20 mm, 10-14 mm grip range (Red Horse)
4. Fixed point sleeve aluminum type 8

To steel profiles

5. Swisspearl stainless steel rivet for Planea and Zenor panels, head Ø 15 mm, blank or powder coated (MBE)
 - 4.0×16-K15, 10-12 mm grip range
 - 4.0×18-K15, 12-14 mm grip range
 - 4.0×20-K15, 14-16 mm grip range
 - 4.0×22-K15, 16-18 mm grip range

Swisspearl stainless steel rivet all Swisspearl panels expect Planea and Zenor panels head Ø 15 mm, blank or powder coated (SFS)

- 4.0×18-K15, 9-14 mm grip range
 - 4.0×23-K15, 14-19 mm grip range
- Rivets (former Cembrit), head Ø 14 mm, RIV-S EPDM washer 4.8×20 mm, 9-13 mm grip range (Red Horse)

6. Fixed point sleeve aluminum type 8

Maritime conditions

Maritime conditions call the use for stainless steel rivets. Those may be used on steel or anodized aluminum sub frame. Maritime conditions are considered within a distance of 1 km (0.6 miles) from the sea. Material specification for sub frame, fasteners and accessories to cater for maritime conditions according to local standards. Ensure that the performance of the support system and accessories used, complies with country specific standards, approvals and regulations.

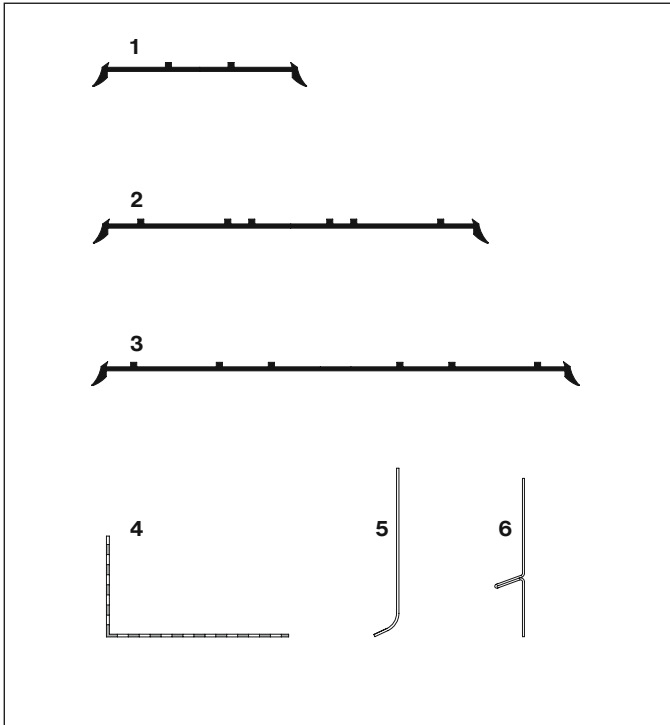
Joint material

1. EPDM band, black, 60 mm wide for intermediate supports with side lips, in 50 m rolls
Local alternativ version 30 mm or 50 mm
2. EPDM band, black, 120 mm wide for butt joints with side lips, in 50m rolls
Local alternativ version 90 mm or 100 mm
3. EPDM band, black, 150 mm wide for inner and outer corners with side lips, in 25m rolls
4. Ventilation profile, raw aluminum or standard colors, 50x30 mm, 70x30 mm, 100x40 mm.
2500 mm long, 0.6 mm thick
5. L-flashing, stainless steel, millor powder coated, 0.5 mm thick
2510 / 3050 mm long
6. Horizontal joint flashing, aluminium, powder coated black, 0.5 mm thick 2510 / 3050 mm long

Profiles are just for illustration purposes. Differences in the local profile portfolio will occur.

Terminology

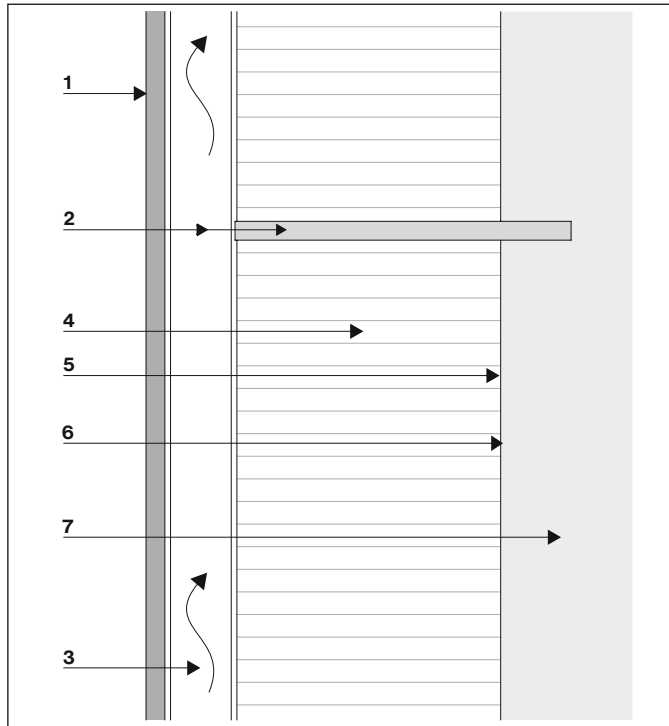

Vertical section

Rear ventilated cladding

The design principle involves the deflection (screening) of the rain water. As the panel joints are not sealed, minimal amounts of water can gain access into the air cavity behind the panel. The cavity is naturally ventilated by vent gaps at bottom and top, so that any moisture will evaporate naturally by thermal action.

Cladding (1)

Panels with open or closed joints, in one plane or lapped.

Sub framing (2)

To support the cladding dead and wind load generally vertical panel supports in timber or metal.

Ventilation cavity (3)

Cavity behind panel with ventilation gaps at bottom and top.

Thermal insulation layer (4)

To increase the thermal insulation capacity of the exterior wall.

Substrate (5)

Face of exterior wall, such as plaster, concrete, exterior sheating, wind proofing layer, etc.

Moisture barrier (6)

To be in compliance with regional codes, the use of a WRB is needed in a rainscreen assembly in order to prevent the penetration of water or moisture into the building.

Exterior wall (7)

Brick, concrete, wood and steel studs

Corner zone

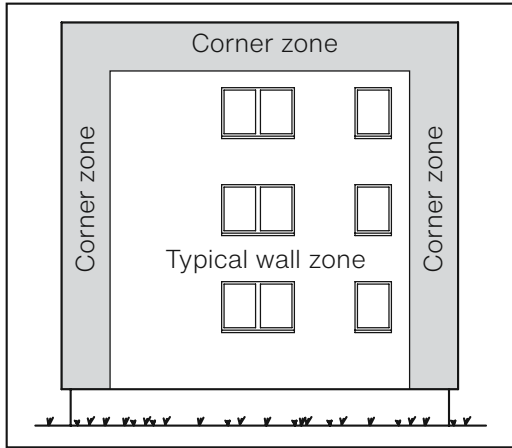

Wind load zones
 As per scheme there are two wind load zones: The corner zones generally are subject to increased negative wind load (suction) due to turbulence at the edges of the building. The applicable wind load values must be determined in the cladding specification.

Min. manufacturer cavity depth:

Mandatory for issuance of the warranty letter.

Cladding height	min. cavity
< 6 m	20 mm
6 - 30 m	30 mm
> 30 m	40 mm

Application

Swisspearl cladding panels can be attached to vertical supports made of timber, aluminium or steel.

Windload

Always consider local standards when determining panel fastener differences. This is especially important for tall buildings, for buildings with special shapes and for high wind exposure areas.

Ventilation cavity

Building tolerances must be allowed for. The cavity may not be reduced by horizontal profiles or any stray objects such as loose insulation and other materials.

Building expansion joints

The buildings structural expansion joints should be considered when designing subframe systems. Structural expansion joints must be applied to sub frame and cladding as provided to the building structure.

Ventilation cavity

Minimum airflow at the back-side of the panels should be 100% free of obstructions with no less than 200cm² of vertical airflow (Min 20mm System depth) behind panels. Minimum air flow at base and top of walls is required to have at least 60% unobstructed ventilation if using ventilated profiles.

Ventilation cavity with perforated horizontal subframe components

Min ventilation gap to be 40 mm. Horizontal profiles should allow min. 75% airflow. In advance please contact your Technical Service for approval.

Panel support

Panel must be supported on an even surface. If perforated angles are placed between the panel and batten/vertical profile the closure piece must not exceed 0.8 mm. Perforated angles have to allow ventilation entrance with a min. perforation of 60%. The use of an aluminium mesh is possible. It has a high ventilation ratio, thin material thickness (no push out of panel) and is easy to install.

Material compatibility

Untreated aluminum material such as Window sills, frames, etc. is not compatible with cement and must be protected against dust from drilling panels, etc. Aluminum components are to be used in anodized or powder-coated or Kynar Coated for exterior applications with protective films.

- 1 Largo
- 2 Fastener
- 3 Panel support
- 4 Perforated angle
- 5 Recess

Timber battens

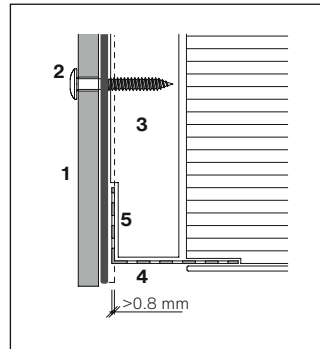

Metal profile

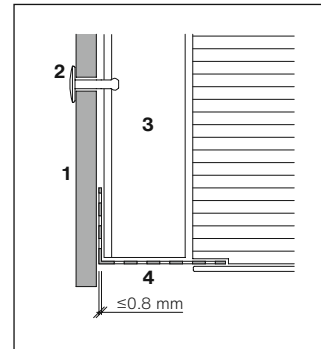
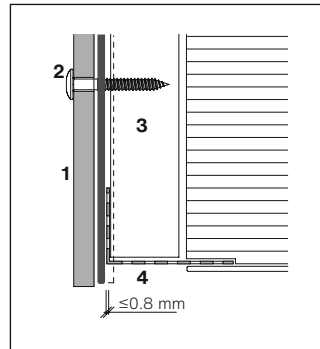
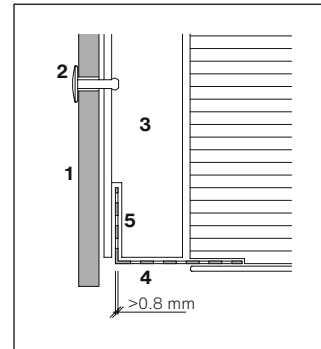

Sealant material

Generally to keep the cladding maintenance free the use of sealants should be avoided. Where the use of sealant is unavoidable Polyurethane, Acrylic or Hybrid Polymer products would be best suitable. Before applying any sealant to fiber cement material the compatibility must be checked as certain materials leave permanent staining on panel surface.

Sub frame types

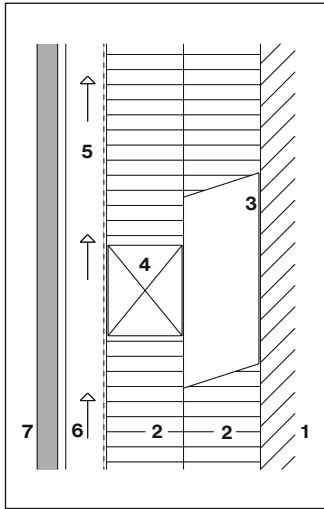

Timber / timber

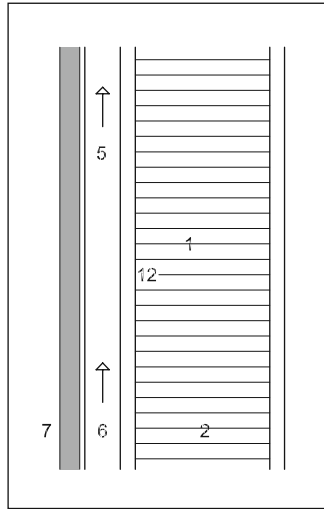

Timber / Windstopper on a light wall system

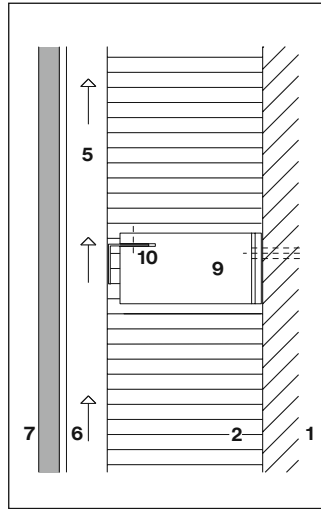

Metal / timber verticals

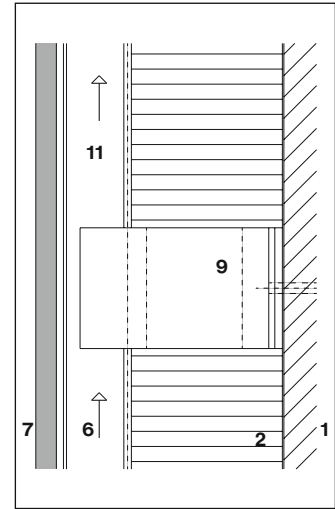

Metal

- 1 Substrate
- 2 Thermal insulation
- 3 Vertical batten
- 4 Horizontal batten
- 5 Panel support
- 6 Vent cavity
- 7 Largo panel

- 8 Spacer screw
- 9 Bracket
- 10 Horizontal batten
- 11 Vertical batten
- 12 Windstopper

Swisspearl rivet

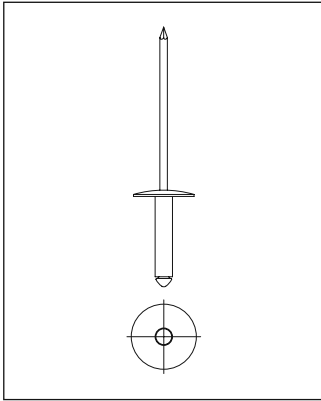

Swisspearl rivet \varnothing 15 mm 4.0x18-K15

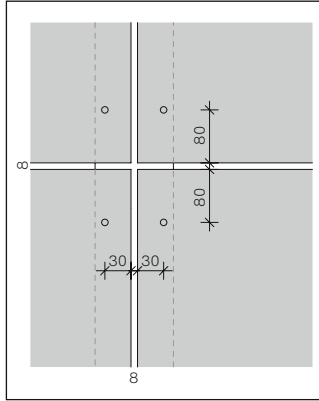

Panel edge distances

Holes in panel for rivets

Diameter 9.5 mm

Standard edge distances

Horizontally 30 mm

Vertically 80 mm

Minimum edge distances

Horizontally 30 mm

Vertically 60 mm

Maximum edge distance

Horizontally and vertically 100 mm

mm

Panel joints

Typical panel joint is 8 mm, this allows panel scraps to be used as spacers. Wider joints will make any inaccuracies in the installation less noticeable.

Fixed, sliding points

Each panel must be fastened by 2 fixed points in the panels center to support the panels deadload. All other rivets are sliding points.

Drill holes \varnothing 4.1 mm to metal profiles

Use centering drill gauge so the holes will be concentric to the \varnothing 9.5 mm hole in the panel. Use drill bit type A for aluminum profiles and type S for steel.

Sub-frame engineering

Engineer / contractor is responsible for the design and installation of all sub frame parts including all pertaining fasteners.

The sliding point connection is **NOT** meant to accommodate building drift or seismic movement.

Aluminium profiles

Aluminum thickness should be a min. of 2 mm. Profiles should not exceed 3 m and profile breaks should coincide with panel joints.

Aluminium rivet

Use Swisspearl rivets powder coated or blank. See page 9 for more information.

Staggered horizontal panel joints

Use two vertical profiles to vertical panel joint so that each can be broken on its horizontal panel joint level.

Black panel joints

Panel joints read as shadow lines. It is recommended to blacken the metal where visible, with paint or PVC paint tape.

Steel profiles

Steel panel supports to be min. gauge 18 (1.27 mm / 0.05") to obtain nominal pull out value. Profiles should not be longer than 6 m (20').

Stainless steel rivet

Use Swisspearl rivets powder coated or blank. See page 9 for more information.

Sub-frame engineering

Engineer / contractor is responsible for the design and installation of all sub frame parts including all pertaining fasteners.

Horizontal joint

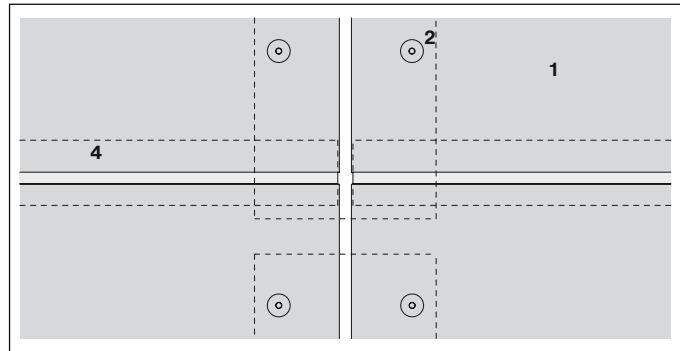
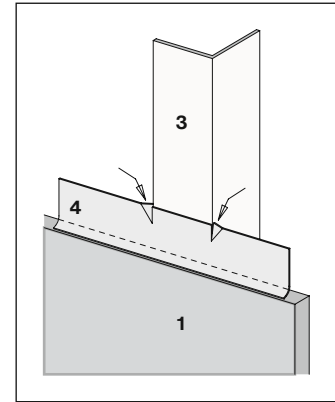
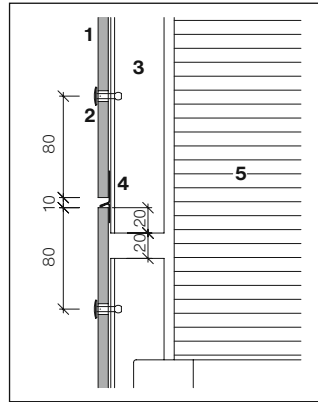

- 1 Largo 8 mm
- 2 Rivet
- 3 Panel support profile
- 4 Joint flashing (optional).
L = panel width - 2 mm.
- 5 Thermal insulation

Any breaks to panel support profiles must be located at panel joints as shown. Flashing cut at one vertical as shown to prevent lateral dislocation of flashing.

Horizontal section

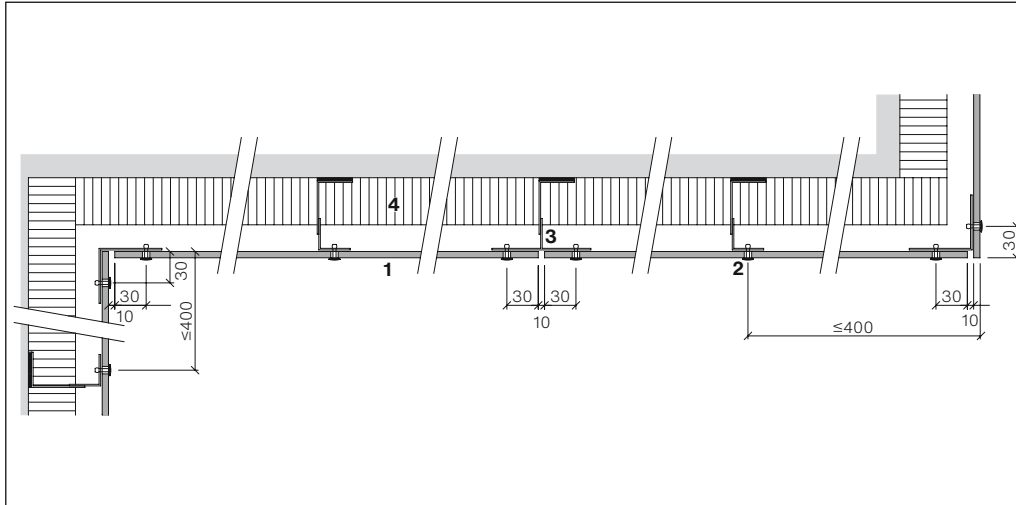

Panel may be cantilevered
max. 400 mm.

- 1 Largo 8 mm
- 2 Rivet
- 3 Aluminum profile
- 4 Thermal insulation

Rivet installation

Use rivet gun GESIPA AC-CUBIRD or similar. Do not use pneumatic equipment. Use centering drill gauge with drill bit Ø4.1 mm to obtain concentric hole [A/5].

Fixed point for Aluminum Sub-frame

Fixed point for Aluminum, Type 8 Ø9.4 mm [B/4]
 • Rivet head Ø15 mm 4.0×18-K15, blank or powder coated, grip range 8-13 mm

Fixed point for Steel Sub-frame

Fixed point steel A2, Type 8, Ø9.4 mm [B/4]
 • SS Rivet, head Ø15 mm, 4.0×18-K15, blank or powder coated, grip range 9-14 mm

Each panel must be fastened by 2 fixed fastening points in the panel center, installed first. All the others are sliding points.

Sliding points for Aluminum Sub-frame

Use centering drill gauge with drill bit Ø4.1 mm to obtain concentric hole [C/5]
 • Alu Rivet, head Ø15 mm 4.0×18-K15, blank or powder coated, grip range 8-13 mm. Sliding points for Steel Sub-frame use center drill gauge with drill bit Ø4.1 mm to obtain concentric hole [C/5]

Sliding points for Steel Sub-frame

• Sliding points for Steel Subframe. Use centering drill gauge with drill bit Ø4.1 mm to obtain concentric hole [C/5]
 • SS Rivet, head Ø15 mm, 4.0×18-K15, blank or powder coated, grip range 9-14 mm

- 1 Support profile
- 2 Largo 8 mm
- 3 Concenter drill gauge
- 4 Fixed point sleeve, type 8
- 5 Rivet 4.0 x 18 - K15

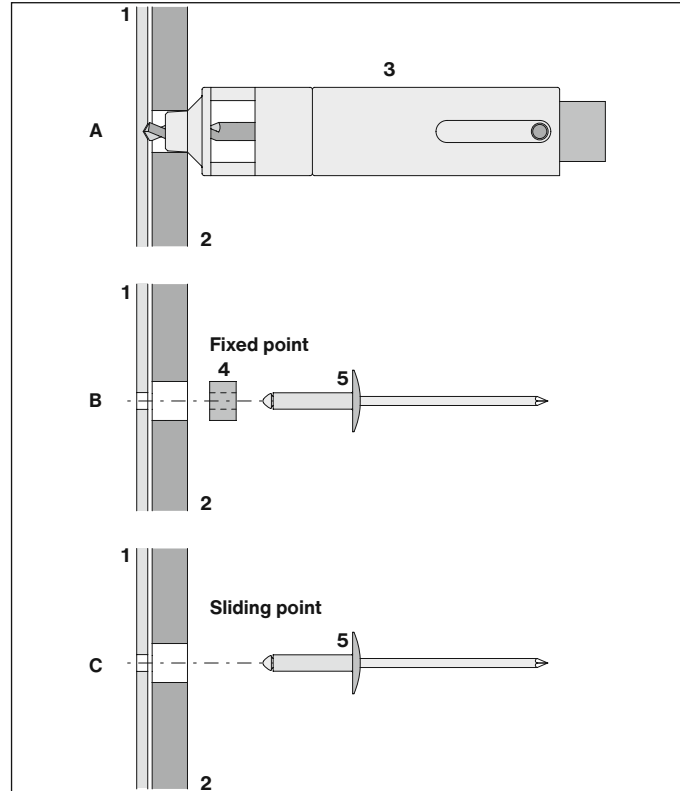

Metal sub frame – 8 mm facade panels – rivet distances

Characteristic value of wind suction (according to European standards)		Design value of wind suction (including a chosen safety coefficient of 1.5)		Recommendation for maximal spacing d (distance between rivets or screws)			
kN/m ²	psf	kN/m ²	psf	Vertical panel (portrait)		Horizontal panel (landscape)	
				horizontally mm	vertically mm	horizontally mm	vertically mm
- 0.70	- 13.90	- 1.0	- 20.90	600	725	725	530
- 1.00	- 20.90	- 1.5	- 31.30	600	590	675	530
- 1.30	- 26.50	- 1.9	- 39.70	600	490	520	530
- 1.80	- 37.60	- 2.7	- 56.40	400	490	430	370
- 2.30	- 48.70	- 3.5	- 73.10	400	420	400	370
- 2.70	- 55.70	- 4.0	- 83.50	400	330	370	370
- 3.30	- 69.60	- 5.0	- 104.40	300	370	370	280
- 4.00	- 83.50	- 6.0	- 125.30	300	330	330	220

Above table is a guide line for 2 or more fasteners in vertical and horizontal direction and only applicable for Swisspearl rivets and screws. The spacings originate from 1250x3050 mm full size panels with equal distances between rivets. Data may be interpolated.

Metal sub frame – 8 mm facade panels – rivet distances**Engineering responsibility**

The spacings in above table are provided as indication. For the actual cladding design a locally licensed engineer shall assume responsibility for calculation and verification.

Panel data

- Modulus of elasticity
MOE ca. 15'000 MPa
- Modulus of rupture
(characteristic)
MOR (average) > 22 MPa
- Design value bending
resistance 8.0 MPa
(2.5 safety factor)
- Density > 1.75g/cm³

Characteristic values**Resistance of aluminum and steel rivets 4.0x18 K15**

Position	Distance between fasteners (spacing)
	600 mm
Middle	2000 N
Edge	1200 N
Corner	950 N

The data was evaluated according to ETAG 034 using 8 mm panel, and includes no safety factor. Diameter of panel hole must be 9.5 mm, and rivet head must be 15 mm.
Min. thickness for steel profiles to be 1.27 mm, and 2 mm for aluminum.
Edge distances 30 mm horizontally, 80 mm vertically. The data may be interpolated.

Metal sub frame – 12 mm facade panels – rivet distances

Characteristic value of wind suction (according to European standards)		Design value of wind suction (including a chosen safety coefficient of 1.5)		Recommendation for maximal spacing d (distance between rivets or screws)			
kN/m ²	psf	kN/m ²	psf	Vertical panel (portrait) horizontally	vertically	Horizontal panel (landscape) horizontally	vertically
				mm	mm	mm	mm
2.08	43.44	3.12	65.16	570	725	725	570
- 2.31	- 48.31	- 3.47	- 72.47	570	670	670	570
- 2.88	- 60.15	- 4.32	- 90.22	570	565	565	570
- 3.39	- 70.73	- 5.08	- 106.09	570	480	480	570
- 4.22	- 88.13	- 6.33	- 132.20	570	385	385	570
- 5.10	- 106.51	- 7.65	- 159.77	380	725	725	380
- 7.09	- 148.00	- 10.63	- 222.00	380	375	375	380
- 8.86	- 185.04	- 13.29	- 277.56	380	300	300	380

Above table is a guide line for 2 or more fasteners in vertical and horizontal direction and only applicable for Swisspearl rivets and screws. The spacings originate from 1250x3050 mm full size panels with equal distances between rivets. Data may be interpolated.

Metal sub frame – 12 mm facade panels – rivet distances**Engineering responsibility**

The spacings in above table are provided as indication. For the actual cladding design a locally licensed engineer shall assume responsibility for calculation and verification.

Panel data

- Modulus of elasticity
MOE ca. 15'000 MPa
- Modulus of rupture
(characteristic)
MOR (average) > 22 MPa
- Design value bending
resistance 8.0 MPa
(2.5 safety factor)
- Density > 1.75g/cm³

Characteristic values**Resistance of aluminum and steel rivets 4.0x24 K15**

Position	Distance between fasteners (spacing)
	600 mm
Middle	1950 N
Edge	1450 N
Corner	1350 N

The data was evaluated according to ETAG 034 using 12 mm panel, and includes no safety factor.

Diameter of panel hole must be 9.5 mm, and rivet head must be 15 mm.

Min. thickness for steel profiles to be 1.27 mm, and 2 mm for aluminum.

Edge distances 30 mm horizontally, 80 mm vertically. The data may be interpolated.

Single span no intermediate support

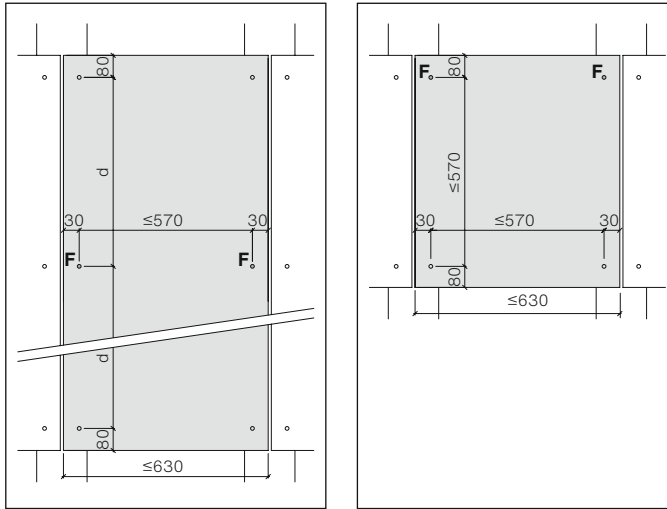

Max. distance between fasteners for single span panels 570 mm, unless smaller distances is required by high wind load as per table of fastener distances.

If more than 3m single span panels are horizontally adjoining each other – the chain of vertical T-profiles must be interrupted with 2 L-profiles

Consult with technical advisor.

Single span

Fixed point \varnothing 9.5 mm [F]
Sliding point \varnothing 9.5 mm

Soffit panels

Fastener distances for soffit panels and suspended ceilings not to exceed 500 mm.

- Fixed point \varnothing 9.5 mm [F]
- Sliding point \varnothing 9.5 mm

Sample rivet layouts, final layout to be determined by a local structural engineer.

Largo vertical panel (portrait)

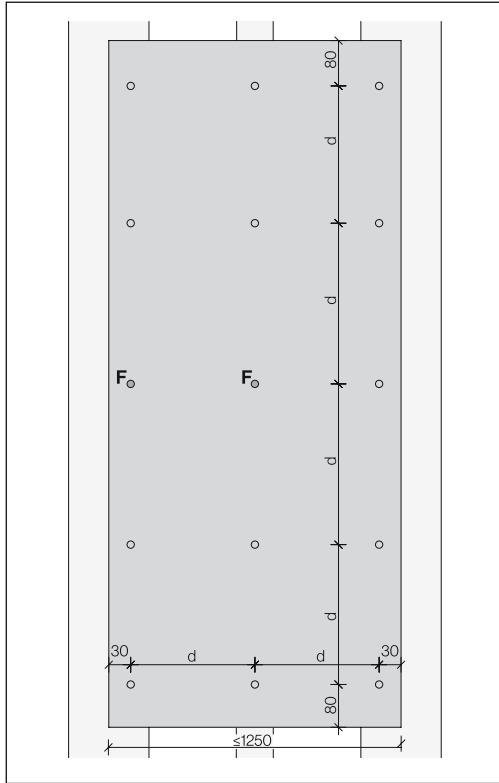

Fixed points [F] center and left.

Largo vertical panel (portrait)

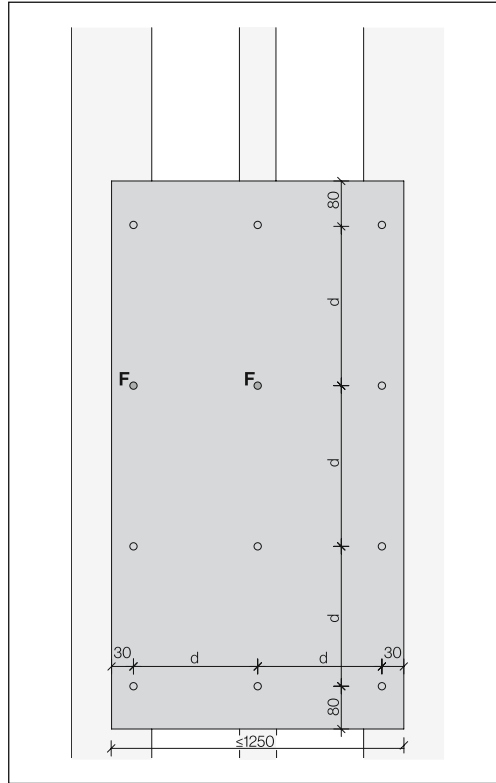

If no rivet at half height go with [F] to row above.

- Fixed point Ø9.5 mm [F]
- Sliding point Ø9.5 mm

Design I Metal supports

Sample rivet layouts, final layout to be determined by a local structural engineer.

Large horizontal panel for odd number of rivets

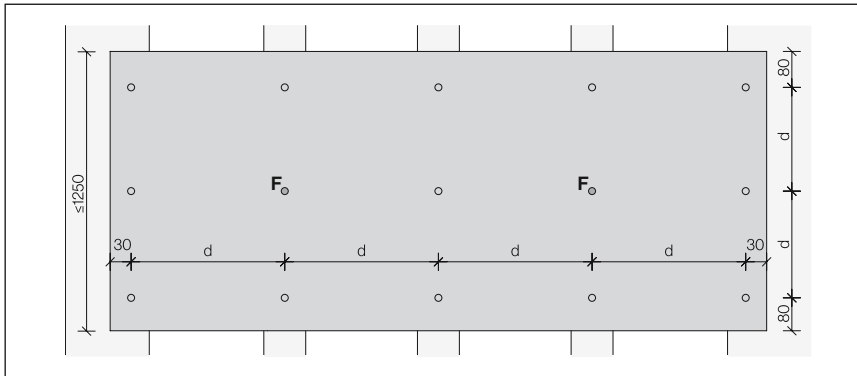

Between fixed points, the max. distance can be 1 sliding point

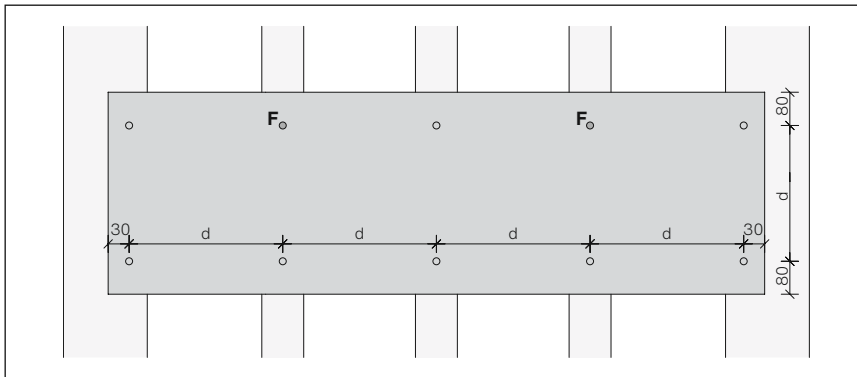

- Fixed point Ø9.5 mm [F]
- Sliding point Ø9.5 mm

Sample rivet layouts, final layout to be determined by a local structural engineer.

Largo horizontal panel (landscape) for even number of rivets

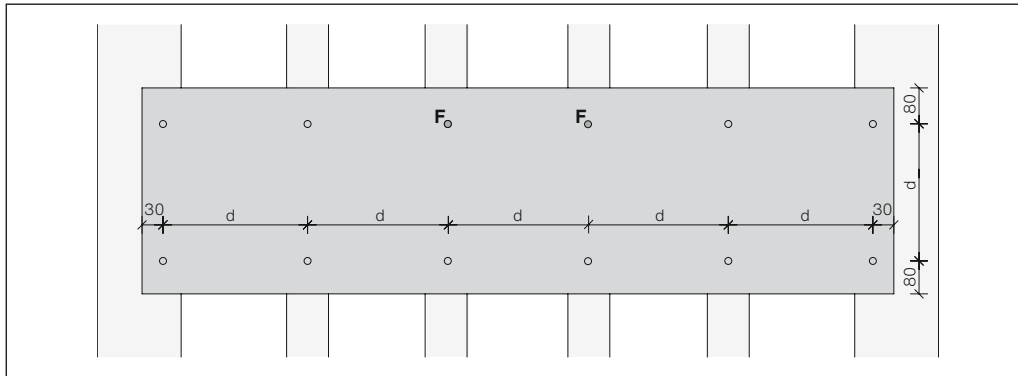
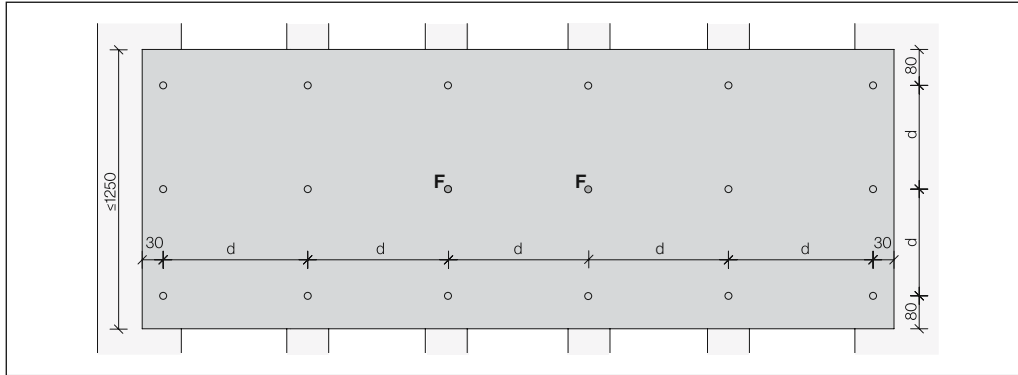

- Fixed point Ø9.5 mm [F]
- Sliding point Ø9.5 mm

Design I Metal supports

Sample rivet layouts, final layout to be determined by a local structural engineer.

Largo stripes

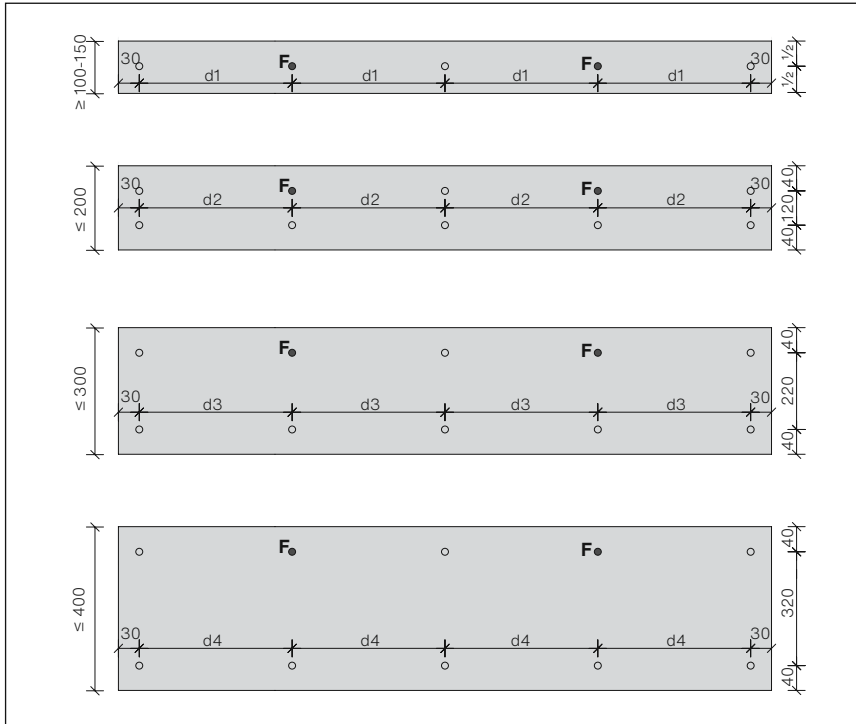

Panel height ≤ 400 mm, the vertical edge distance might be reduced to a min. 40 mm.

Fastener distances [d1-d4]

Wind load	$\leq 0.45 \text{ kN/m}^2$
Building height up to (m)	≤ 10
Strip width 100-150 mm [d1]	400
Strip width ≤ 200 [d2]	450
Strip width ≤ 300 [d3]	500
Strip width ≤ 400 [d]	see page 19

- Fixed point $\varnothing 9.5 \text{ mm [F]}$
- Sliding point $\varnothing 9.5 \text{ mm}$

Holes in panel for rivets

Fastener holes to be done at the jobsite. Diameter 9.5 mm.

Installation Reflex, Vintago and Vintago – Reflex

When installed, all the arrows on the backside of the Reflex, Vintago and Vintago-Reflex panels must point in the same direction.

Fixed point for Aluminum Sub-frame

Fixed point for Aluminum, Type 8 diameter 9.4 mm [B/4]

- Rivet head diameter 15 mm 4.0×18-K15, blank or powder coated, grip range 8-13 mm.

Fixed point for Steel Sub-frame

Fixed point steel A2, Type 8, diameter 9.4 mm [B/4]

- SS Rivet, head diameter 15 mm, 4.0×18-K15, blank or powder coated, grip range 9-14 mm.

Drill holes diameter 4.1 mm to metal profiles

Use concenter drill gauge so that the holes will be concentric to the diameter 9.5 mm hole in the panel. Use drill bit type A for aluminum profiles and type S for steel.

Details

Installation details as per this DIM are applicable.

Example outer corner

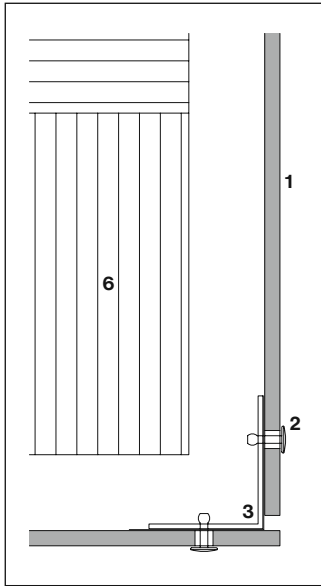

Example inner corner

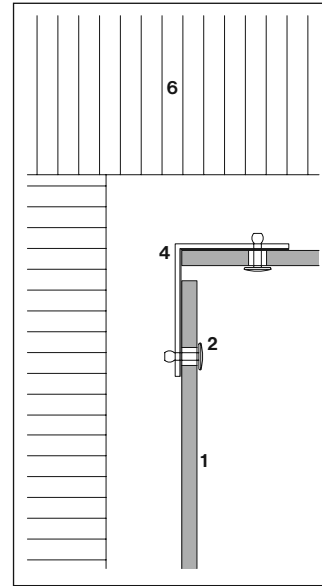
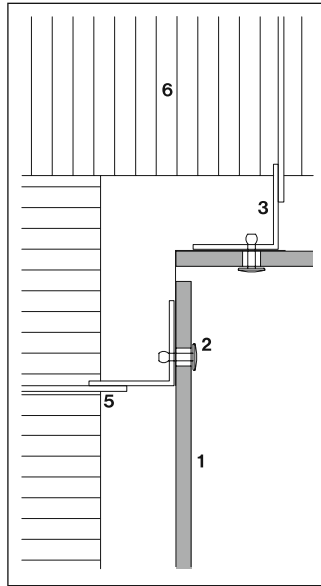

- 1 Largo 8 mm
- 2 Rivet 4.0x18-K15
- 3 Min. angle 60 x 60 mm
- 4 Min. angle 70 x 60 mm
- 5 Bracket
- 6 Thermal insulation

Corner angle not attached back to building as shown can be cantilevered up to 400 mm

Example window jamb

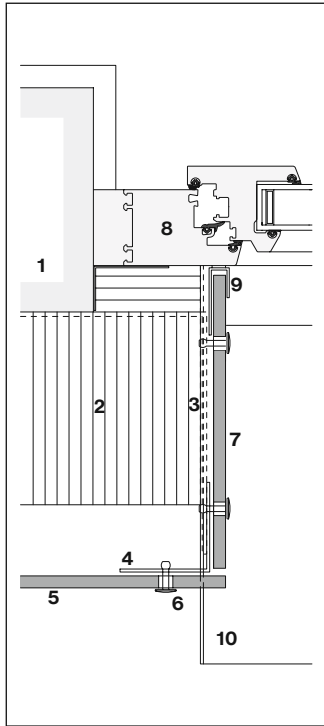

Jamb with 8 mm panel

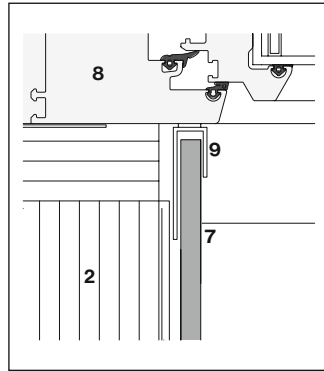

Window jamb with metal frame

- 1 Exterior wall
- 2 Thermal insulation
- 3 Horizontal support
- 4 Vertical support
- 5 Largo 8 mm
- 6 Rivet 4.0 x 18 K15
- 7 Largo jamb board 8 mm
- 8 Window frame
- 9 U or F-profile with sealant
- 10 Window sill

Example window sill

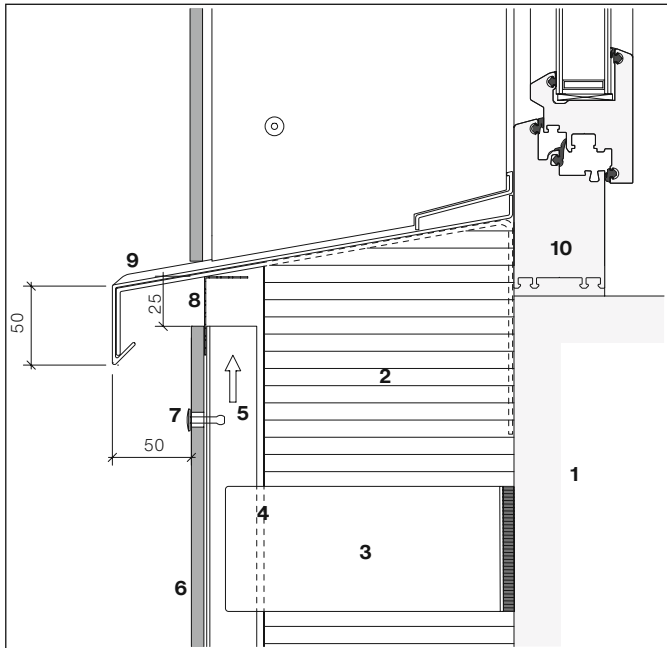

Window sill made of metal

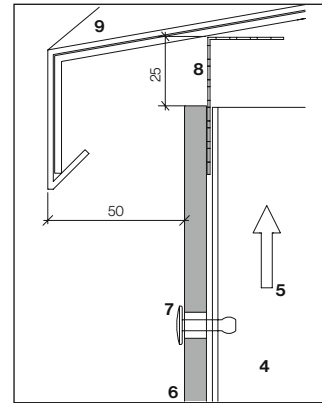

Sill detail

- 1 Exterior wall
- 2 Thermal insulation
- 3 Bracket
- 4 Vertical support
- 5 Ventilation cavity
- 6 Largo 8 mm
- 7 Rivet 4.0×18-K15
- 8 Perforated angle
- 9 Window sill
- 10 Window frame

Example window head

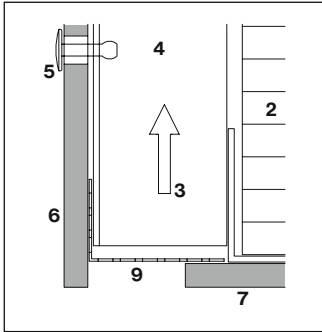

Perforated angle

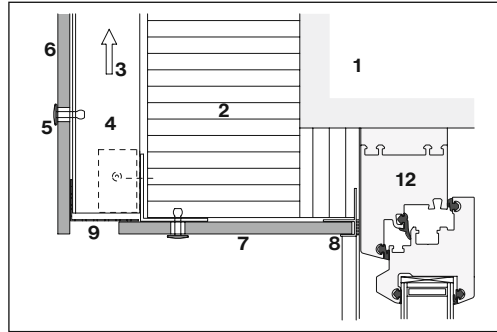

Metal framing around whole window

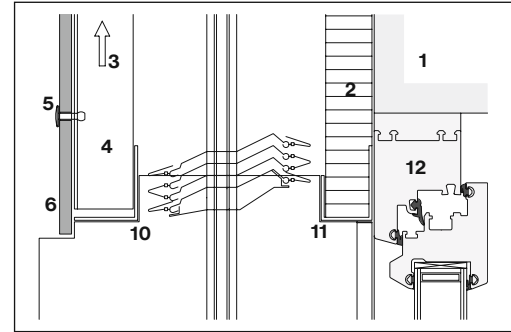

Head detail sun shutter

- 1 Exterior wall
- 2 Thermal insulation
- 3 Ventilation cavity
- 4 Vertical support
- 5 Rivet 4.0x18-K15
- 6 Largo 8 mm
- 7 Largo 8 mm

- 8 U or F-profile
- 9 Perforated angle
- 10 Reinforcing profile
- 11 Angle profile insulation
- 12 Window frame

Example bottom detail

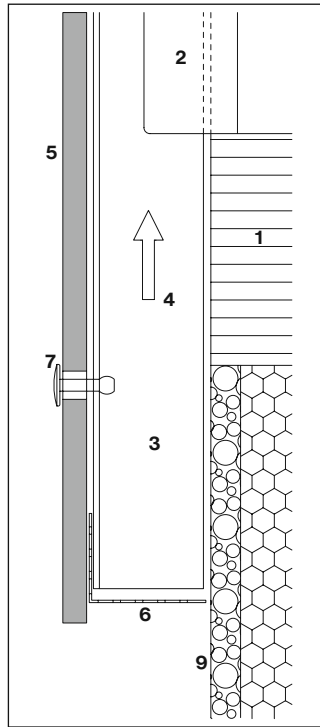
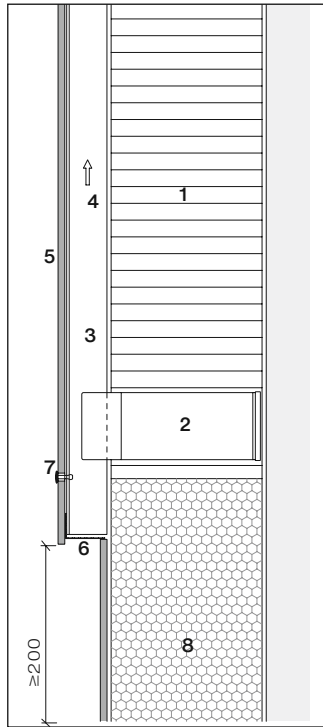

- 1 Thermal insulation
- 2 Bracket
- 3 Vertical support
- 4 Ventilated cavity
- 5 Largo 8 mm
- 6 Perforated angle
- 7 Rivet 4.0×18-K15
- 8 Thermal insulation
- 9 Thermal insulation water resistant

In order to avoid damages its advised to keep a minimum distance of 200mm from bottom of the panel to the ground

Swisspearl screw

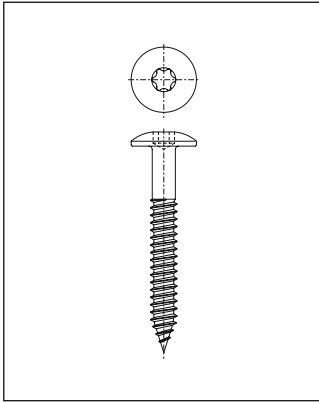

Swisspearl screw, stainless steel, saucer head \varnothing 12 mm, T20 drive

Distances to panel edge

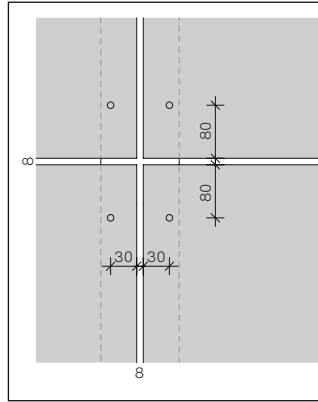

Panel hole

Diameter 5.5 mm

Standard edge distances

Horizontally 30 mm

Vertically 80 mm

Minimum edge distances

Horizontally 25 mm

Vertically 60 mm

Maximum edge distance

Horizontally and vertically max. 100 mm

Panel joints

Typical panel joint is 8 mm, this allows panel scraps to be used as spacers. Wider joints will make any inaccuracies in the installation less noticeable.

Installation

The screws must be installed with depth stop at 90 degrees set to the panel. The screw head must rest even to the panel.

Sub-frame engineering

Engineer / contractor are responsible for the design and installation of all sub framing parts including all pertaining fasteners.

Timber battens

The standard and moisture content for timber battens used as substructure should follow local rules and regulations.

Timber battens

Installation over timber battens is allowed provided the design meets local engineered codes and standards.

Timber quality

Battens must be thickness gauged to 1 face:

- Thickness min. 27 mm (min. 3/4")
- Always use planed surface timber
- Solidity class II (FK II/C24)
- Recommended only using kiln-dried lumber
- Moisture content max. 20-%
- Timber must be of equal of higher quality

Vertical battens

At panel joints:
 2x27x60 mm or
 1x27x120 mm
 Intermediate supports:
 27x60 mm

Timber battens for boards installed on windstopper

Installation over timber battens is allowed provided the design local engineered codes and standards.

Timber quality

Thickness min 20mm

Country specific thickness:

- Always use plane surface wood
- Use treated wood of high quality
- If untreated wood is used then it is recommended that the wood is fully covered by EPDM

Vertical battens

At panel joints:
 Min. 20x98 mm
 Country specific thickness:

Intermediante supports:
 Min 20x45mm
 Country specific thickness:

Engineering

Battens including their attachment to be engineered per local standards. For battens wider than 60 mm then it is recommended to use two screws per point of attachment.

Joint flashing

Horizontal joint and L-flashing should be 2 mm shorter than panel and thus not visible in vertical joints. If required butt joint the flashings on any batten, do not overlap flashing.

As L-flashings and horizontal joint flashing are not always 100% waterproof! Then it is highly recommended that all timber battens must be fully covered by EPDM bands to protect them against moisture and to prevent rotting and the growth of fungi and mold.

EPDM strips

All untreated timber battens should be fully covered by EPDM backing strips stapled to the battens. This may vary from country to country in certain cases see local regulations. For treated battens this is not a demand, it is highly recommended to also have the treated wood fully covered by EPDM backing strips. Stapled at the edges of the bands. EPDM strips to be in one single piece top to bottom or overlapped as per diagram.

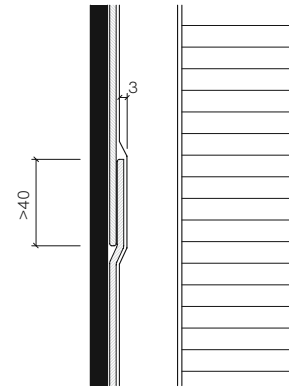

EPDM strip overlap

Horizontal panel joint

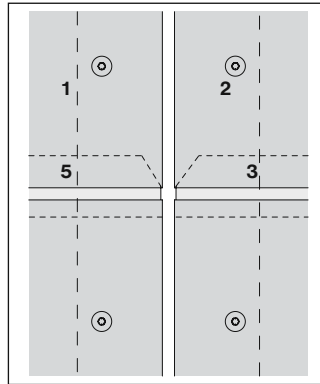
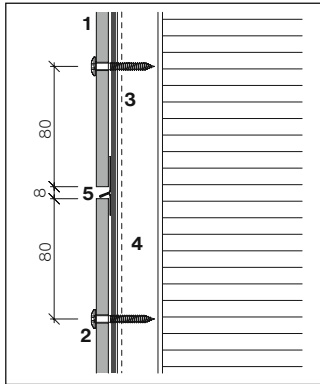

- 1 Largo 8 mm
- 2 Screw
- 3a EPDM band 60 mm
- 3b EPDM band 120 mm
- 3c EPDM band 150 mm
- 4 Batten 27×60, 27×120 mm
- 5 Joint flashing

Horizontal section through vertical battens

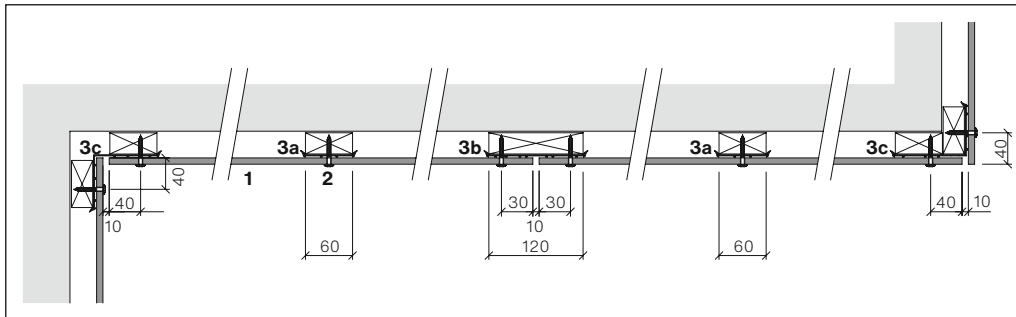

Vertical joint at window

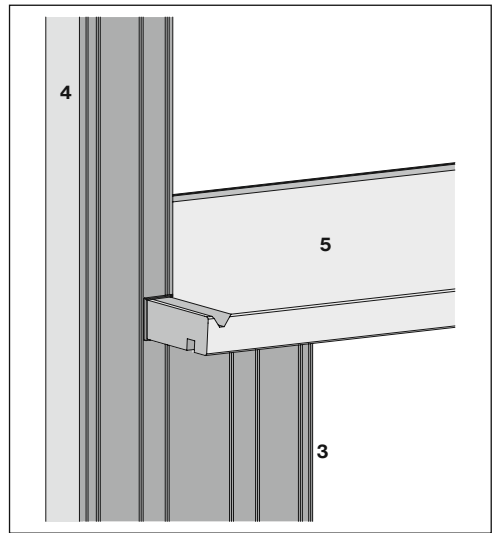
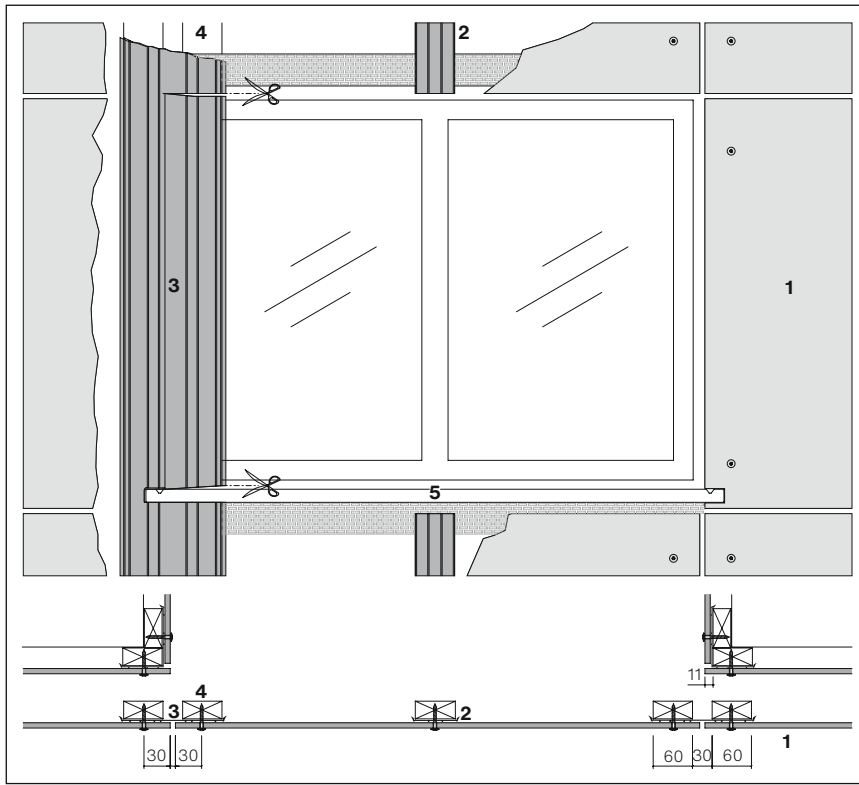

- 1 Largo 8 mm
- 2 EPDM band 60 mm
- 3 EPDM band 150 mm
- 4 Batten 27×60 mm
- 5 Swisspearl window sill

Timber battens – 8 mm facade panels – screw distances

Characteristic value of wind suction (according to European standards) kN/m ² psf		Design value of wind suction (including a chosen safety coefficient of 1.5) kN/m ² psf		Recommendation for maximal spacing d (distance between rivets or screws)			
				Vertical panel (portrait)		Horizontal panel (landscape)	
				horizontally mm	vertically mm	horizontally mm	vertically mm
- 0.70	- 13.90	- 1.00	- 20.90	600	725	725	530
- 1.00	- 20.90	- 1.50	- 31.30	600	590	675	530
- 1.30	- 26.50	- 1.90	- 39.70	600	490	520	530
- 1.80	- 37.60	- 2.70	- 56.40	400	490	430	370
- 2.30	- 48.70	- 3.50	- 73.10	400	420	400	370
- 2.70	- 55.70	- 4.00	- 83.50	400	330	370	370
- 3.30	- 69.60	- 5.00	- 104.40	300	370	370	280
- 4.00	- 83.50	- 6.00	- 125.30	300	330	330	220

Above table is a guide line for 2 or more fasteners in vertical and horizontal direction and only applicable for Swisspearl rivets and screws. The spacings originate from 1250x3050 mm full size panels with equal distances between screws. Data may be interpolated.

Engineering responsibility

The spacings in above table are provided as indication. For the actual cladding design a locally licensed engineer shall assume responsibility for calculation and verification.

Panel data

- Modulus of elasticity
MOE ca. 15'000 MPa
- Modulus of rupture
(characteristic)
MOR (average) > 22 MPa
- Design value bending
resistance 8.0 MPa
(2.5 safety factor)
- Density > 1.75g/cm3

Characteristic values

Resistance of screws 4.8x38 Ø 12 mm

Position	Distance between fasteners (spacing)
	600 mm
Middle	2000 N
Edge	1100 N
Corner	700 N

The data was evaluated according to ETAG 034 using 8 mm panel, and includes no safety factor. Diameter of panel hole must be 5.5 mm, and screw head must be 12 mm. Minimum screw engagement in timber to be 27 mm. Edge distances 30 mm horizontally, 80 mm vertically. The data may be interpolated.

Timber battens – 12 mm facade panels – screw distances

Characteristic value of wind suction (according to European standards)		Design value of wind suction (with a safety coefficient of 1.5)		Recommendation for maximal spacing d (distance between rivets or screws)			
kN/m ²	psf	kN/m ²	psf	Vertical panel (portrait)		Horizontal panel (landscape)	
				horizontally mm	vertically mm	horizontally mm	vertically mm
2.23	46.64	3.35	69.97	530	725	725	530
- 3.00	- 62.65	- 4.50	- 93.99	530	580	580	530
- 3.83	- 80.05	- 5.75	- 120.10	530	465	465	530
- 4.24	- 88.55	- 6.36	- 132.84	530	420	420	530
- 5.97	- 124.74	- 8.96	- 187.14	350	465	465	350
- 6.95	- 145.07	- 10.42	- 217.64	350	410	410	350
- 7.96	- 166.23	- 11.94	- 249.39	350	365	365	350
- 9.00	- 187.95	- 13.50	- 281.97	350	325	325	350

Above table is a guide line for 2 or more fasteners in vertical and horizontal direction and only applicable for Swisspearl rivets and screws. The spacings originate from 1250x3050 mm full size panels with equal distances between screws. Data may be interpolated.

Engineering responsibility

The spacings in above table are provided as indication. For the actual cladding design a locally licensed engineer shall assume responsibility for calculation and verification.

Panel data

- Modulus of elasticity
MOE ca. 15'000 MPa
- Modulus of rupture
(characteristic)
MOR (average) > 22 MPa
- Design value bending
resistance 8.0 MPa
(2.5 safety factor)
- Density > 1.75g/cm³

Characteristic values

Resistance of screws 4.8x44 Ø 12 mm

Position	Distance between fasteners (spacing)
	600 mm
Middle	4000 N
Edge	1450 N
Corner	1350 N

The data was evaluated according to ETAG 034 using 12 mm panel, and includes no safety factor. Diameter of panel hole must be 5.5 mm, and screw head must be 12 mm. Minimum screw engagement in timber to be 27 mm. Edge distances 30 mm horizontally, 80 mm vertically.

The data may be interpolated.

Single span panel (no intermediate support)

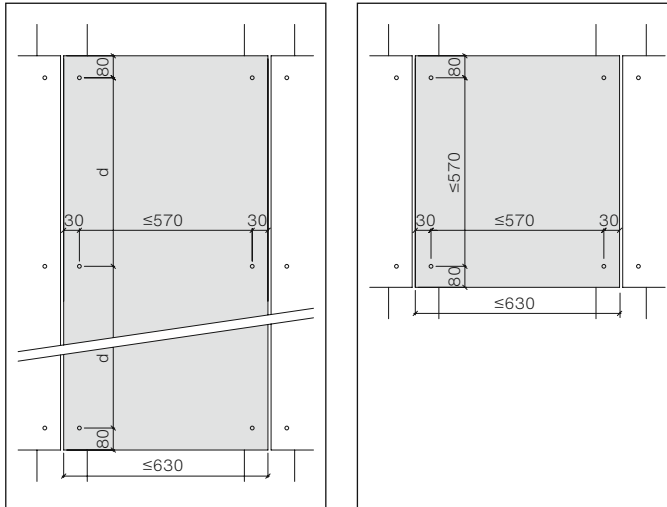

Soffit panels

Fastener distances for soffit panels and suspended ceilings not to exceed 500mm.

Max. distance between fasteners for single span panels 570 mm, unless smaller distance is required by high wind load as per table of fastener distances.

Sample screw layouts, final layout to be determined by a local structural engineer.

Largo vertical panel (portrait)

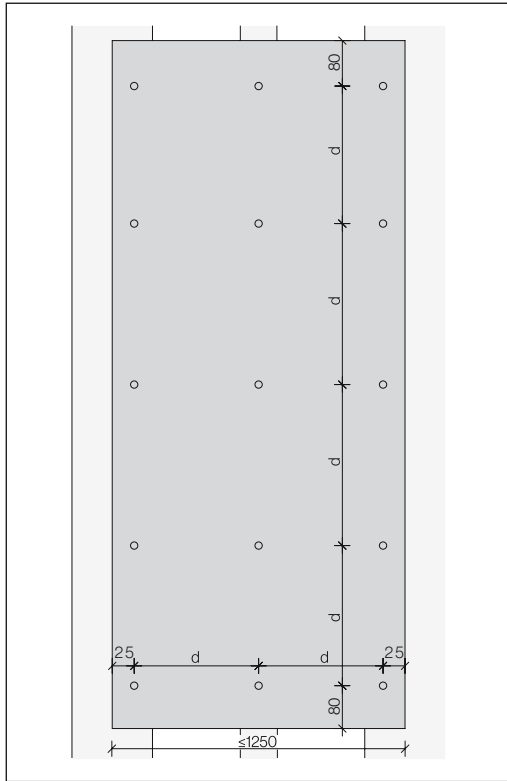

Largo horizontal panel (landscape)

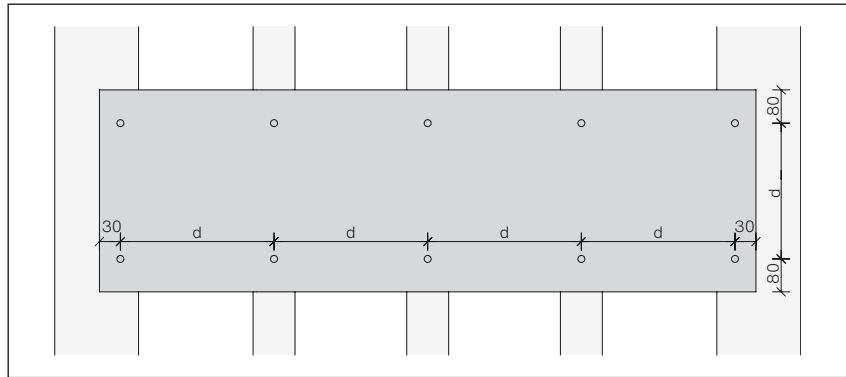
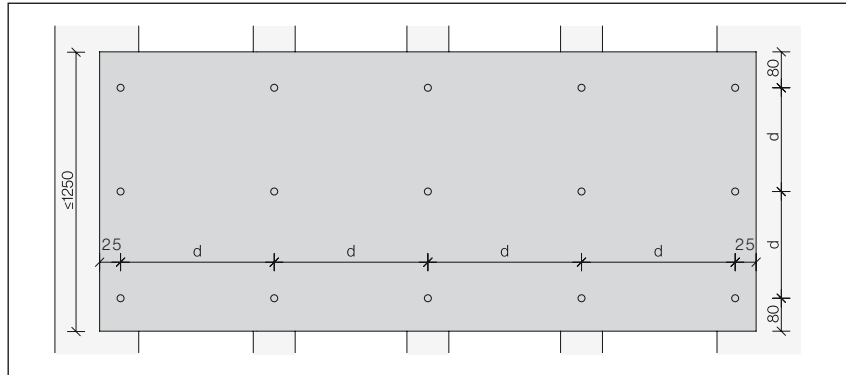

Drill holes \varnothing 5.5 mm

Largo strips

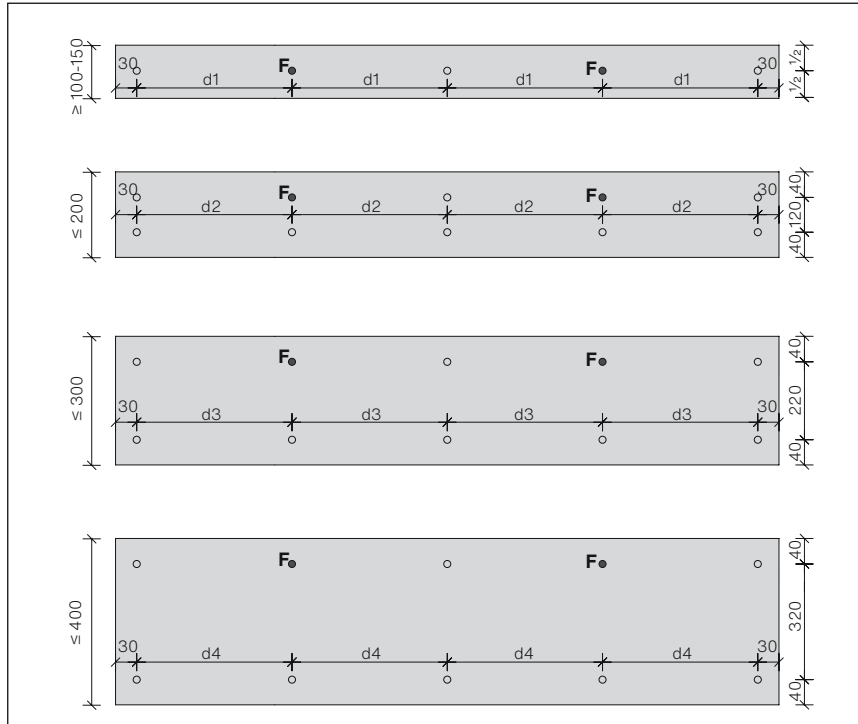

Panel height ≤ 400 mm, the vertical edge distance might be reduced to a min. 40 mm.

Fastener distances [d1-d4]

Wind load	$\leq 0.45 \text{ kN/m}^2$
Building height up to (m)	≤ 10
Strip width 100-150 mm [d1]	400
Strip width ≤ 200 [d2]	450
Strip width ≤ 300 [d3]	500
Strip width ≤ 400 [d]	see page 40

Holes in panel for screws

Fastener holes to be done at the jobsite. Diameter 5.5 mm.

Installation Reflex, Vintago and Vintago - Reflex

When installed, all the arrows on the backside of the Reflex, Vintago and Vintago - Reflex panels must point in the same direction.

Timber battens

Installation over timber battens is allowed provided the design meets local engineered codes and standards.

EPDM strips

All untreated timber battens Should be fully covered by EPDM backing strips stapled to the battens. This may vary from country to country in certain cases see local regulations. For treated battens this is not a demand, it is higley recomened to also have the treated wood fully covered by EPDM backing strips. Stapled at the edges of the bands.

Mandatory the use of Swisspearl EPDM bands with side lips.

Details

Installation details as per this DIM are applicable.

Timber battens

Installation over timber battens is allowed the design meets local engineered codes and standards.

Timber quality

Battens must be thickness gauged to 1 face:

- Thickness min. 27mm (min. 3/4")
- Always use planed surface timber
- Solidity class II (FK II/24)
- Recommended only using kiln-dried lumber
- Moisture content max. 20-%
- Timber must be of equal of higher quality

Vertical battens

At panel joints:
2×27×60 mm or
1×27×120 mm
Intermediate supports:
27×60 mm

Timber battens for boards installed on windstopper

Installation over timber battens is allowed provided the design local engineered codes and standards.

Timber quality

Thickness min 20mm

Country specific thickness:

- Always use plane surface wood
- Use treated wood of high quality
- If untreated wood is used then it is recommended that the wood is fully covered by EPDM

Vertical battens

At panel joints:
Min. 20×98 mm
Country specific thickness:

Intermediante supports:

Min 20×45mm
Country specific thickness:

Largo example outer corner

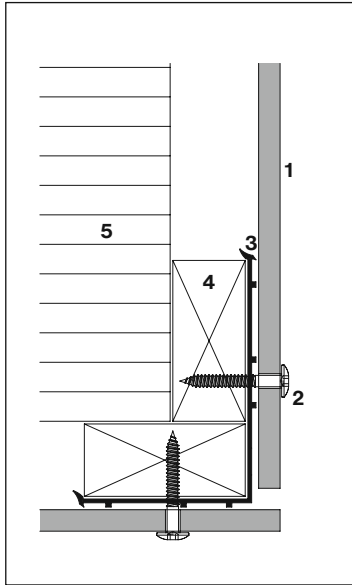

Largo example inner corner

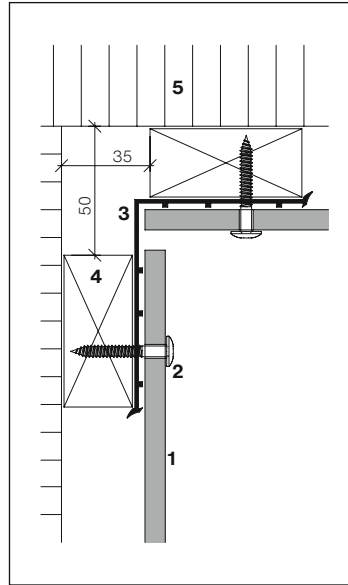

- 1 Largo 8 mm
- 2 Swisspearl Screw 4.8×38 mm
- 3 EPDM band 150 mm
- 4 Batten 27×60 mm
- 5 Thermal insulation

Batten configuration to building corner as shown above with the use of 150 mm EPDM.

Example window jamb

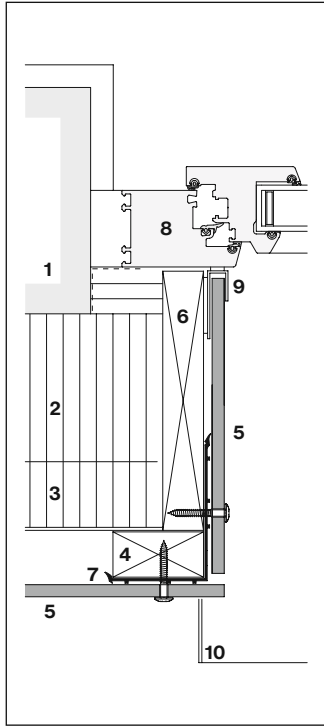

Jamb with 8 mm panels

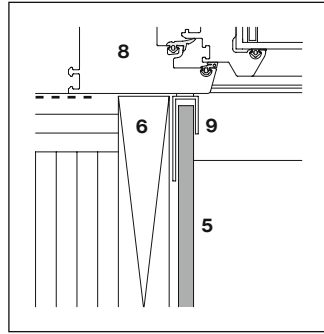

Window detail

- 1 Exterior wall
- 2 Thermal insulation
- 3 Horizontal support
- 4 Vertical support
- 5 Largo 8 mm
- 6 Jamb board
- 7 EPDM band 150 mm
- 8 Window frame
- 9 U or F-profile
- 10 Window sill

Example window head

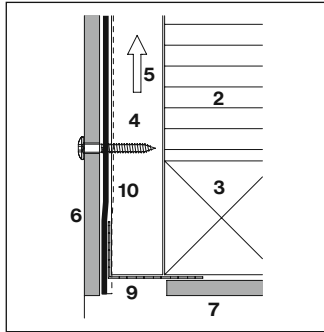

Perforated angle

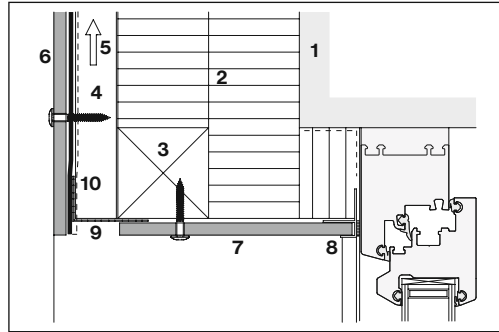

Metal framing around whole window

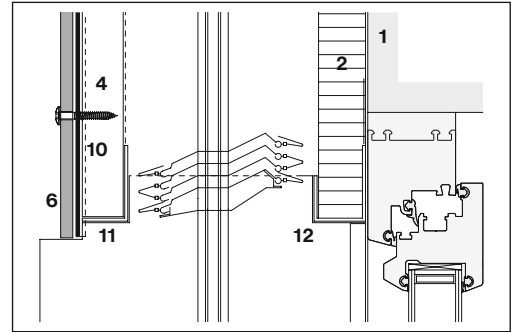

Head detail sun shutter

- 1 Exterior wall
- 2 Thermal insulation
- 3 Horizontal support
- 4 Vertical support
- 5 Ventilation cavity
- 6 Largo 8 mm
- 7 Largo 8 mm

- 8 U or F-profile with sealant
- 9 Perforated angle
- 10 EPDM band
- 11 Angle profile
- 12 Angle profile insulation

Example bottom detail

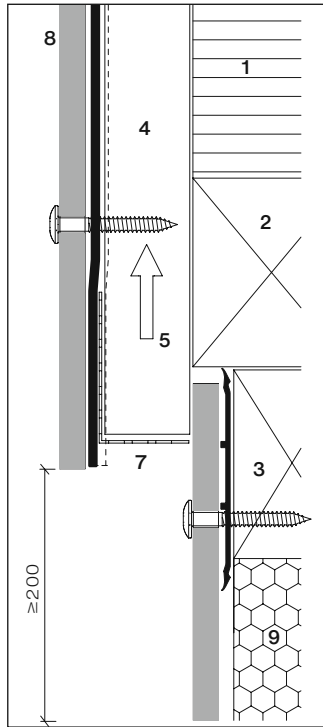

Timber / timber

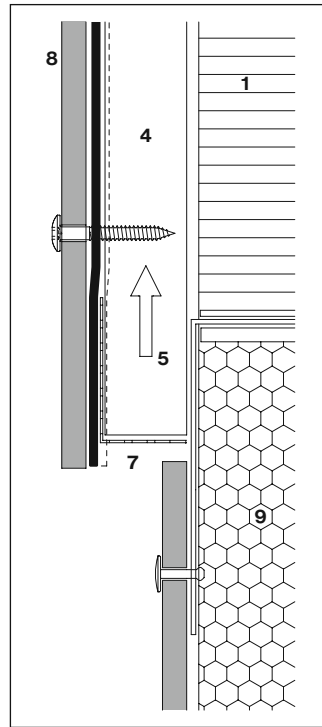

Timber / metal

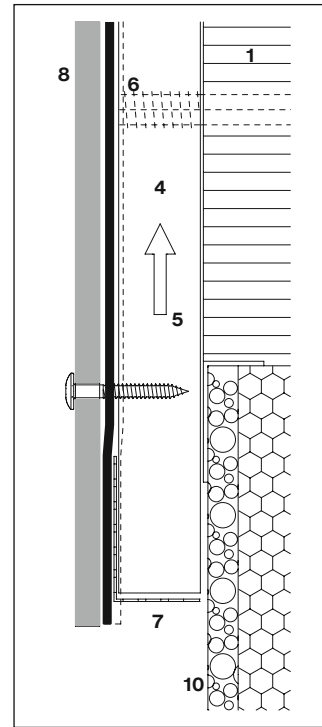

Timber verticals with spacer screw

- 1 Thermal insulation
- 2 Horizontal batten
- 3 Horizontal support
- 4 Vertical support
- 5 Ventilated cavity
- 6 Spacer screw
- 7 Perforated angle
- 8 Largo 8 mm
- 9 Thermal insulation water resistant
- 10 Thermal insulation

Example coping detail

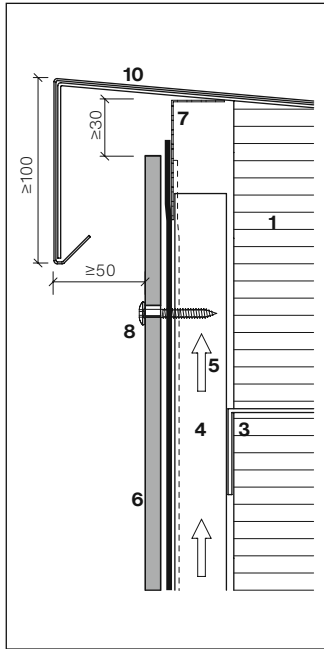

Coping detail

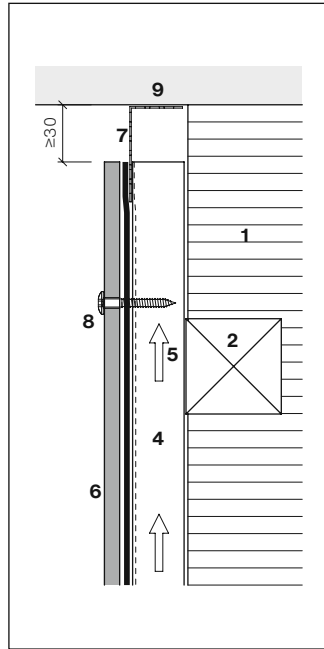

Detail under slab

- 1 Thermal insulation
- 2 Horizontal batten
- 3 Horizontal support
- 4 Vertical support
- 5 Ventilated cavity
- 6 Largo 8 mm
- 7 Perforated angle
- 8 Screw
- 9 Soffit
- 10 Coping

On site storage

Pallets must be stored under cover i.e. out of rainfall and direct sunlight. Where this is not possible, store under tarp. Ingress of water into stacked panels will cause permanent staining to panel surface. Excess heat to stacked panels can cause damage to panel surface. Overseas pallets can be stacked several above another.

Provisional roofing or tarp covers are to be used in a manner that allows cross ventilation as shown.

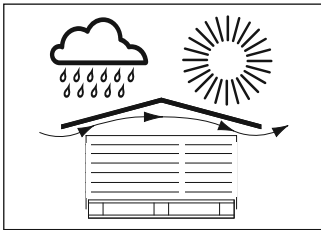

Fabricating panels at local fabricators or on site

Always work out of the weather. Cutting panels to size:

- Use industrial vertical panel saw for large quantities
- For small quantities use circular hand saw with straight edge and dust extraction
- Panel cut outs, etc. use jig saw
- Cutting blade supplied by factory or procured locally; considering cutting quality, performance, costs
- Dust from fabricating on site must be removed immediately
- Avoid tools which produce fine dust

Stacking panels on site

- Always stack the panels horizontally on pallet base
- Each stack should not be more than 500 mm high (1' 18")
- Use foam protection layer between the panels (as supplied by factory)
- 4 stacks on top of each other

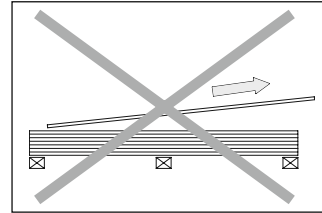

Do not pull panel across...

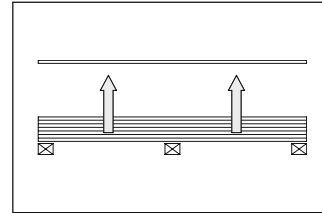

...but lift up vertically

Pallet sequence

It is recommended to order the panels cut and pre-drill according to their sequence in the order to save time while installing.

Panel fabrication on site

For long cuts use multifunction table with circular hand saw, guide rail and dust extractor. Saw blade supplied by panel manufacturer or at own choice.

Cut outs

For smaller cut outs or odd shapes use pendular jig saw. For drilling use spiral drill bits on site storage $\varnothing 9.5$ / $\varnothing 5.5$ mm (metal / timber supports) with carbide metal tips supplied by panel manufacturer or procured locally.

Protective foil Swisspearl Largo Zenor and Planea

Swisspearl Largo Zenor and Planea come with a protective foil applied to the surfaces. The foil is referred to as a sticky foil as it remains on the surface when handling the boards. Mark the foil for pre-drilling holes for the screws and rivets and pre-drill through the foil. The foil can also be used for marking for cutting. In the same way as drilling, leave the foil on while cutting the board.

The protective foil can also be used for edge sealing, but it is crucial that it adheres completely to the surface to prevent sealant from getting underneath the foil. Excess edge sealant must be removed immediately after application, and it should be avoided getting the edge sealant on the front of the board, as this could cause visible stains.

Remove the foil just before installation to make sure there are no damages or flaws on the board. **DO NOT** wait until screws or rivets are fitted.

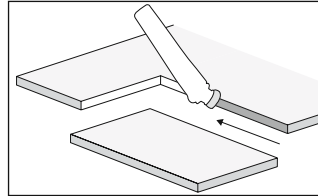
Sealer to cut edges

All cut edges must be sealed with impregnation liquid LUKO. Immediately wipe LUKO off the face of the material.

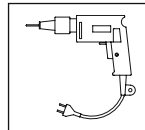
Tools

Drill

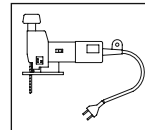

Jig saw

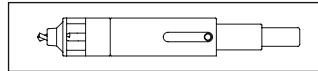

Center drill gauge

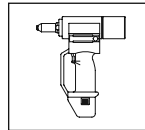

Rivet gun

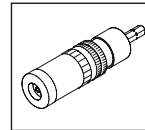
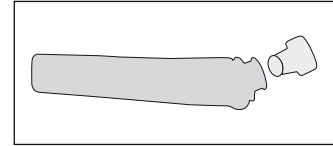
Depth stop
(mandatory for
timber sub-frame)**LUKO hand applicator**

LUKO filled in hand applicators is frost proof to -8°C (18°F). LUKO supplied in 1 liter bottles is not frost proof but dries faster (for fabrication in work shop).

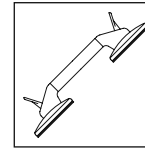

Vacuum handle with silicone cups. (Keep silicone cups clean during installation to prevent scratching panels).

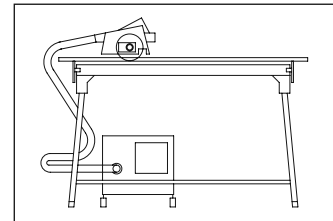

Circular hand saw with guide rail and dust extraction

Swisspearl panels including

Carat, Avera, Reflex, Vintago, Vintago - Reflex, Nobilis, Terra, Planea and Zenor including those panels with an added Facade and or Roof coatings fall into these categories.

Cleaning procedures

Remove dust immediately after fabricating panels.

Dry dust

To be removed with a vacuum cleaner, or with a clean, dry and soft cloth or brush.

Wet dust

Results in staining the panel surface. It must be removed immediately, using plenty of water and a sponge or soft brush.

Cleaning of completed claddings

Non calcium based stains:

- Use high pressure cold water at max. 80 bars (minimum distance from panel 25 cm/10"). Use flat fan spray nozzle, dirt blasters are not allowed. Prior do test on inconspicuous part of cladding
- If required use mild soap or dish-washing liquid. Do not use abrasive or solvent containing cleaning agents
- Do not use glass cleaning detergents!
- Never wash claddings in direct sun light with alkaline or acid cleaners, as the detergent may cause irreversible stains

Calcium based stains:

- Apply a mist spray of a solution of 9.5% acetic acid and water
- Allow to react a few minutes but do not let dry out
- Use high pressure cold water to rinse cladding

Repeat steps 1 to 3 on difficult stains.

Cleaning during service life

Normally no cleaning will be needed since the rain will periodically wash away dust, environmental dirt, etc. However, if particular environmental conditions lead to a dirty surface, wash with garden hose or high pressure cold water.

Cleaning of HR panels

Clean the surface with a soft cloth, remove with Acetone using a different soft cloth. Apply 2-3 times treatment if necessary. If the surface is not acceptable after the 3rd time, a change of the panel is recommended.

Do not clean the surface in direct sun light, and always use appropriate safety equipment. For detailed specifications on HR panels please contact your Technical Advisor.

Organic growth

Remove algae / fungii with a 5% solution of hydrogen peroxide (H₂O₂) to eliminate all spores.

Masking tape

For the use of masking tape on panels it should be noted that most common masking tapes are not resistant to UV rays. Such tapes leave behind residues, that cannot be removed without causing damage to panel surface or detaching the panel surface directly. However the use of the following masking tapes is recommended:

- Masking tape 3M Blue 2090 for temporary application (1 - 2 weeks)
- Masking tape 3M Gold 244 for longer term application.



[swisspearl.com](https://www.swisspearl.com)