

DIM Design & Installation Manual

Sigma 8 Pro – Facade system



Notes, Miscellaneous		Remarks, Validity, Advantages, Project Related Material Orders	3
System description		Character, System, System configuration	4
Program	Panel sizes	Overview panel sizes, Technical specifications	5
	Installation information	Appearance and panel direction, Planning and assembly	6-7
	Accessories	System accessories	8
		Accessories for Wood sub-construction and Metal sub-construction	9
		Accessories for additional holes	10
Planning	Installation details	Planning, Fabrication, Suspension parts, cleats, Joints, Rear ventilation	11
		Air Intake and exhaust openings, Scaffolding, Joint compounds, Back of panel	11
		Back pressure, Wind load, Building height, Measurements	12
		Positioning, Edge area	12
		Sub-construction types, Axis dimensions determination, Conciliation	13-15
		Cleat layout	16- 18
		Suspension track, Migration protection, Axes on components	19-23
		Mounting distances, Examples Sigma 8 Pro Vertical, Horizontal	24-25
		Single-plate panel, Mounting distances strips, Installation	26-27
		Notes on installation, Horizontal joint sheet	28-29
Design	Timber panel supports	Support panels, Fasteners, Joints, Attachment	30
		Assembly U-cleats, Omega cleats	31-33
		Outer corner, Inner corner, Windows, Roof edge, Facade base	34-43
	Metal panel supports	Light metal and steel panel support, Attachment	44
		Assembly U-cleats, Omega cleats	44-47
		Outer corner, Inner corner, Windows, Roof edge, Facade base	48-57
	Scaffolding anchor,	Retrofitting	58
	Replacing panels	Setting up the work site	59
Installation	Construction site equip- ment	Construction site interim storage, Guidelines, Transportation	60
	Specifications	Edge impregnating, Cut outs and blanks, tools	61
	Processing, Tools	Masking tape, Cleaning	62
	Cover work, Cleaning		

Remarks

This DIM (Design + Installation Manual) provides technical information regarding design and installation. Refer to area manager and local distributor for further information such as:

- Terms of delivery
- Pricing
- Products and colors
- Lead time, etc.

More general information available on swisspearl.com

CH- 8867 Niederurnen
+41 55 617 11 60
info@swisspearl.com

Validity:

At the time of Installation the most recent documentations are applicable; they are available at swisspearl.com

Advantages

The suspended, ventilated facade with Largo panels offers the following advantages:

- Optimal weather protection
- Ideal in terms of structural engineering
- Installation possible in any season (dry mortarless construction)
- High quality of living due to a healthy indoor climate in winter and summer
- Easy assembly with tried and proven technology
- Sophisticated detail solutions
- Problem-free handling of building tolerances
- Sustainable, durable and stable in value

Project-related

Materials ordering
The unique material character of the Largo fiber cement panels is characterized, among other things, by its natural raw material components. These can vary in appearance, or color nuance for the different production batches. Please note: In order to ensure that production for connected facade areas is coordinated, material orders for a project must be issued in full or, depending on the size, in corresponding subunits such as facade sides or building stages etc.

Disclaimer

The information and recommendations contained in this Design & Installation Manual ("DIM") are offered as a service to architects, contractors, installers, and other persons involved with our products and are not intended to relieve them from their own responsibility. The information and recommendations provided herein are believed by Swisspearl Group to be accurate at the time of preparation of this DIM, or obtained from sources believed to be generally reliable. Swisspearl Group makes no warranty concerning the accuracy of the content of this DIM and shall not be liable for claims relating to any use regardless of whether it is claimed that the information or recommendations are inaccurate, incomplete, or otherwise misleading. The information and recommendations herein are intended to be used with the judgment and experience of professional personnel competent to evaluate the significance and limitations of the material contained. SWISSPEARL GROUP EXPRESSLY DISCLAIMS ANY GUARANTEES AND WARRANTIES, EXPRESSED OR IMPLIED, INCLUDING, BUT NOT LIMITED TO ANY EXPRESS OR IMPLIED WARRANTIES OF MERCHANTABILITY OR FITNESS FOR A PARTICULAR PURPOSE, FOR ANYTHING DESCRIBED OR ILLUSTRATED HEREIN, AND ASSUMES NO RESPONSIBILITY OR LIABILITY FOR DAMAGES OF ANY KIND, INCLUDING - WITHOUT LIMITATION - BODILY HARM, INJURY OR DAMAGE TO PROPERTY INCURRED FROM (1) THIS DIM, (2) THE USE OF THE INSTRUCTIONS IN THIS DIM, OR (3) THE INSTALLATION OR USE OF THE MATERIALS DESCRIBED HEREIN.

Character

Large-format Largo fiber cement facade panels, invisibly mounted, for a high-quality design of impressive building envelopes according to the principles of the suspended, ventilated facade.

System

The Sigma 8 Pro facade system consists of Largo facade panels with a nominal thickness of 8 mm, the dimensions of which can be project-related freely determined keeping in mind the maximum useful format of 3050×1250 mm. The invisible attachment is done with specific, optimally coordinated system components. The fiber cement panels are cut to specifications for each project at the Swisspearl plant and provided with the routed system undercuts on the back. This is done according to the customer's dimension specifications. The hook-in fasteners belonging to the system, available from Swisspearl, are mounted at the construction site at the fix points.

The well-designed system concept of the hook-in cleats enables the installation of Sigma 8 Pro on standard spacer screws, wood-metal, metal and thermal bridge optimized sub-constructions.

- 1 Largo panel 8 mm
- 2 Omega cleat S8 Pro
- 3 Hook-in cleat S8 Pro
- 4 U-cleat S8
- 5 SR2 S8 stainl. screws, Inox, 4.8×30 mm, powder-coated black
- 6 Threaded anchors S8 Pro
- 7 Spacer S8 Pro
- 8 Hex nut with flange and locking tothing
- 9 Migration protection K S8, bare stainless steel

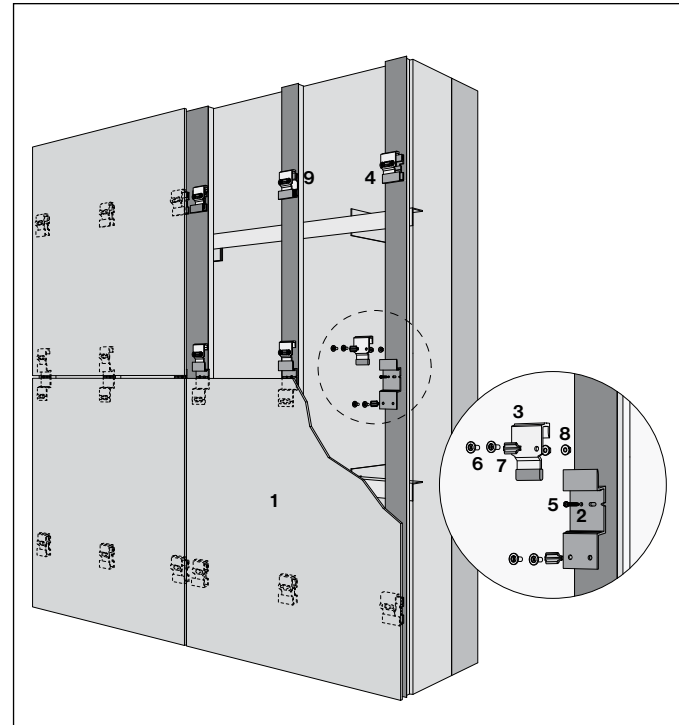
Sigma 8 Pro system

Overview

Largo		Nobilis Nobilis HR Planea Terra	Carat Carar HR Reflex Avera Vintago
Thickness	mm	8	8
Surface mass	approx. weight kg/m ²	15.7	15.7
Format	mm		
Original panels	max. usable format		
3070 × 1270	3050 × 1250	■	■
2530 × 1270	2510 × 1250	■	■
2030 × 1270	2010 × 1250	■	
3070 × 950	3050 × 930	■	
2530 × 950	2510 × 930	■	

Nobilis- and Carat-HR for Largo large formats
 The HR panels have a one-sided, factory-applied special coating for the Nobilis and Carat colors with protective effect against heavy contamination and graffiti.

Overview panel sizes

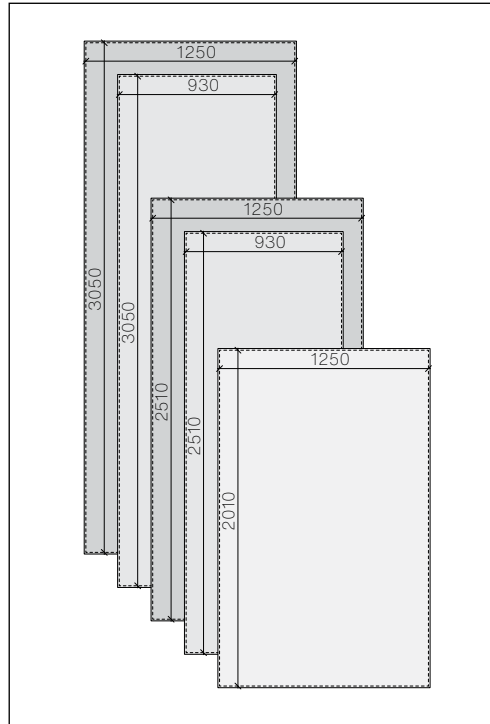

Panel thickness 8 mm: Maximum usable formats [mm]

Product data

- Density 1.8 g/cm³
- Modulus of elasticity ca. 15000 MPa
- Design resistance for bending ca. 8.0 MPa
- Thermal expansion coefficient 0.01 mm/mK
- Fire classification according to NFPA 285 EN 13 501-1 & A2-s1, d0
- Frost resistance and durability under EN 12467
- Thermal range -40°C to +80°C

Overview of the colors and panels available depending on the format
 For window jamb and header under-sides, see: «The facade, program and colors».

Surface, appearance and panel direction

The iridescent reflex surface as well as Vintago are perceived differently depending on the light and the viewing angle. This exciting effect originates in the Reflex's special surface finish and the production direction of the panels. In the Vintago model, this effect is created by a linear grinding pattern. The Reflex and Vintago panels must always be laid in the same orientation, to create a uniform color aspect in the facade surface area.

Planning, Assembly

The installation direction of the Reflex, Vintago and Vintago - Reflex surfaces are important during planning and installation. Always follow the directional arrows on the back of the panels.

Identification

The Reflex and Vintago panels are marked on the back with arrows indicating the manufacturing direction. They always run parallel to the long side of the uncut original panel.

Order

When ordering, the parts list form must be enclosed with details about the arrow directions. The Reflex and Vintago panels are cut according to these binding specifications.

Support program

A coverage & optimization tool with special Reflex and Vintago support is available to assist you when ordering Largo panels.

The tool can be found at swisspearl.com

Positioning

It is recommended to order the panels by their positions, in the order of their assembly sequence.

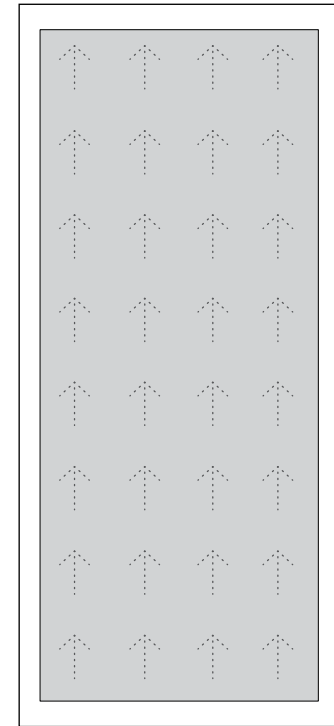
Panel back for Reflex, Vintago

A grid of small arrows has been placed on the back side for better recognition.

Planning, assembly Reflex, Vintago

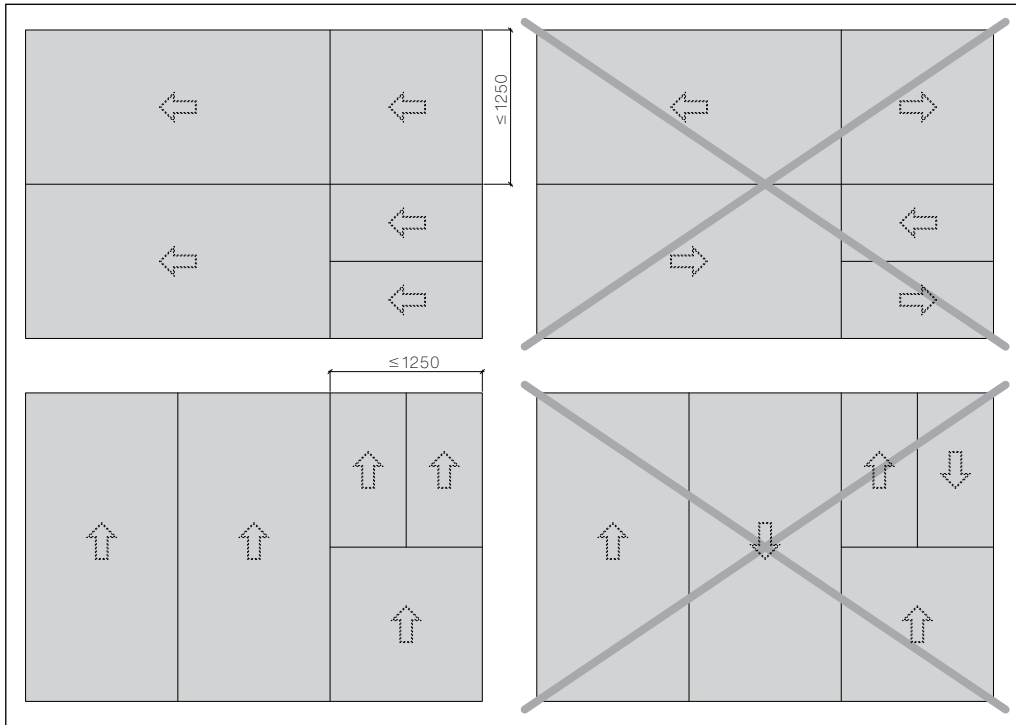

Facade view (colored side)

The arrow marks on the back of the Reflex, Vintago and Vintago - Reflex panels must be arranged in the same direction. To avoid assembly errors, observe the direction of the arrow as follows:

Arrow direction of the horizontally installed panels:
From right to left

Arrow direction of the vertically installed panels:
From bottom to top

Cutting per CAD drawing

When ordering panels with slanted cuts, cutouts or perforations, the drawings must provide arrows to identify the installation direction, with the visible side (colored side) always facing forward.

System accessories

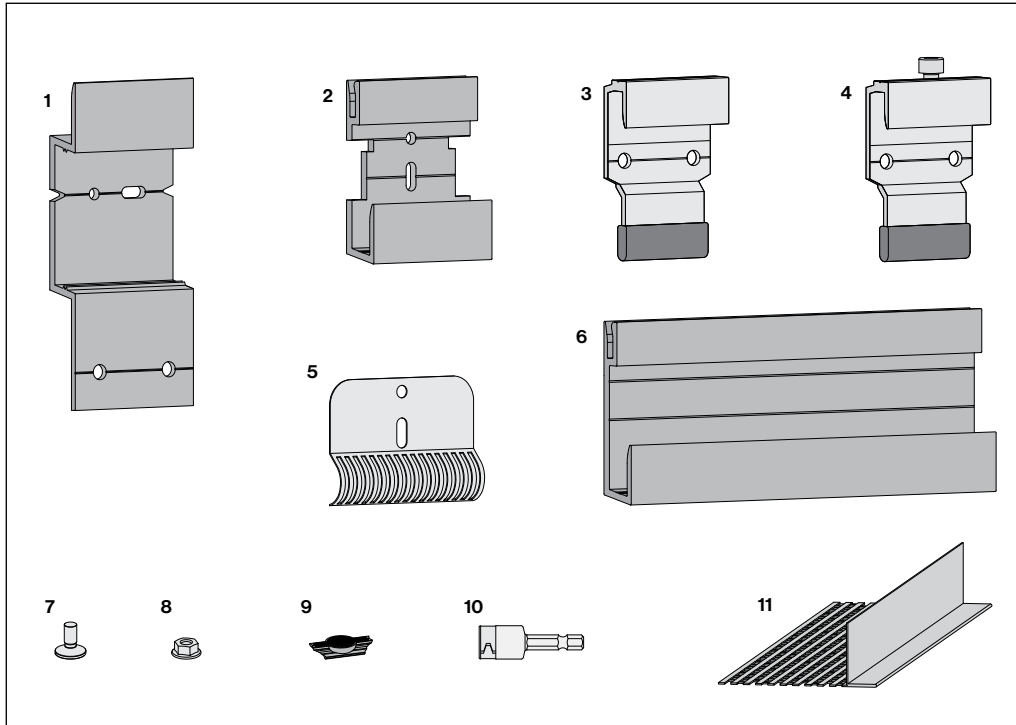

- 1 Omega cleat S8 Pro, aluminum, black anodized
- 2 U-cleat S8, black anodized aluminum
- 3 Hook-in cleat S8 Pro, Alu with TPE
- 4 Hook-in cleat S8 Pro with adjustment (Allen 5)
- 5 Migration protection K S8, bare stainless steel
- 6 U-profile rod S8, aluminum, black anodized (rods 3 m each, standard product line)
- 7 Threaded anchors S8 Pro
- 8 Hex nut with flange and locking toothing
- 9 Spacer S8 Pro
- 10 Wrench socket M6
- 11 Ventilation profile S8 aluminum 0.8mm blank or in color, partially perforated, length 2500 mm

Accessories for wood sub-constructions

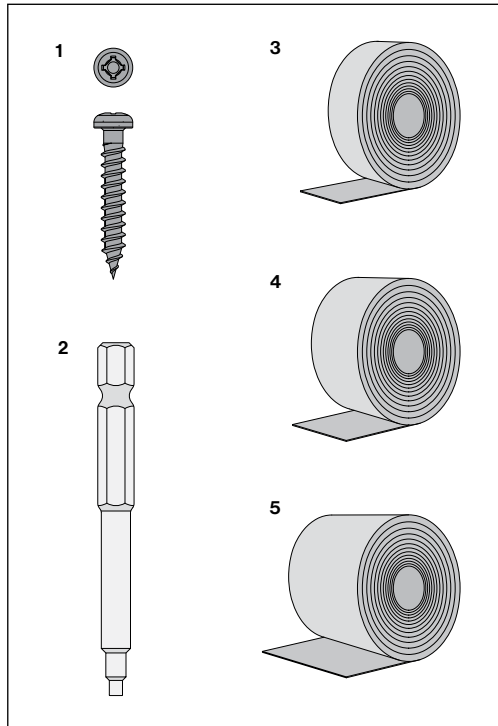

Accessories for metal sub-constructions

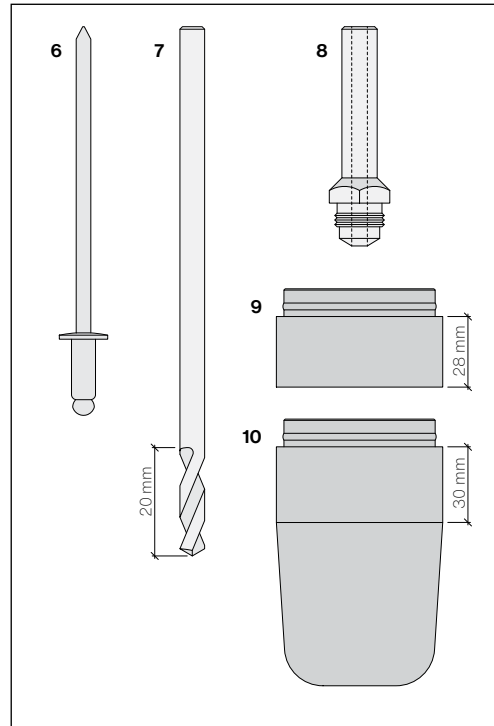

- 1 SR2 S8 screws Inox for wood sub-constructions, screw head $\varnothing 8$ mm SR2 type, 4.8×30 mm, black powder coated
- 2 SR2 insert S8 70 mm
- 3 EPDM tape S8 black, for intermediate support 70 mm width
- 4 EPDM joint tape S8 black, for butt joints, outer and inner corner joints 160 mm width
- 5 EPDM joint tape S8 black, for window axes 180 mm width
- 6 Rivets S8 with special mandrel - Inox for aluminum and steel sub-constructions, Rivet head $\varnothing 9$ mm, 4.8×12 mm, powder-coated black, grip length 5.5 - 8 mm
- 7 Drill bit $\varnothing 4.9$ mm S8 type A for aluminum, type S for steel length 90 mm
- 8 Mouthpiece S8 to Gesipa AccuBird®
- 9 Gesipa-AccuBird®, extension to receiving container 28 mm for rivets S8 with special mandrel
- 10 Gesipa-AccuBird Pro®, extended receiving container 30 mm for rivets S8 with special mandrel

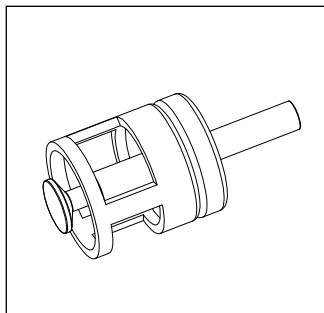
Accessories for added drillings with router (available on request)

System drill S8 Pro

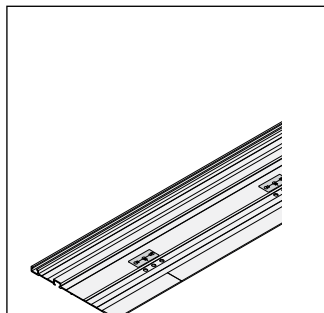

Guide rail S8 Pro

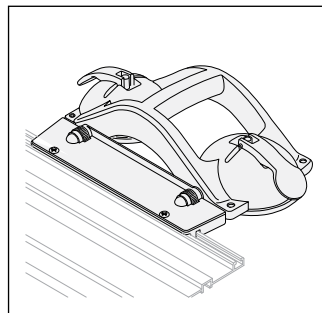

Festool, double suction lifter

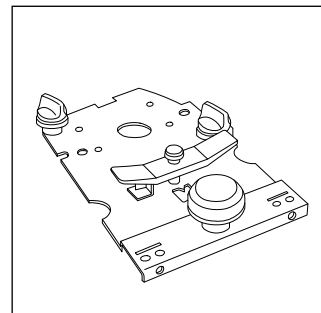

Festool, guide plate FP-LR 32

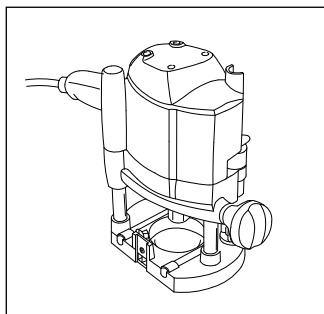

Festool, router, on site

System drill S8 Pro

The system drill S8 Pro is equipped with a calibrated depth stop. The shaft diameter is 8 mm. The maximum permissible rotational speed is 10,000 rpm and must not be exceeded.

Guide rail S8 Pro

The guide rail S8 Pro is specially made for the Sigma 8 Pro bores. The length of the guide rail is 1400 mm.

«GECKO» double suction lifter

The guide rail can be securely fixed to the back of the panel using the «GECKO DOSH double suction lifter.

FP-LR 32 guide plate

The FP-LR 32 guide plate is the connecting element between the guide rail and the router.

Festool, router

The complex Sigma 8 Pro on-site bores can only be milled with Festool routers.

The following compatible routers are commercially available.

- Router OF 1010 R
- Router OF 1400 (optional)

Conditions

In case of dry holes, the maximum allowed is three on-site drillings per panel.

A detailed video guide is available in the QR-Code:



Planning

Facades designed with the Sigma 8 Pro system are technically and aesthetically of superior quality. Early, object-specific facade planning is essential to ensure clear procedures and well-aligned coordination of all building envelope components. The efficient on-site assembly can then be carried out on the basis of these specifications.

Fabrication

The production of Largo facade panels takes place on a project-related basis according to binding customer specifications. The panels are fabricated to project-related dimensions at the Swisspearl plant, the edges are waterproofed and the routed Sigma 8 Pro system undercuts are placed on the back.

Suspension components, cleats

The S8 Pro hook-in cleats, available from Swisspearl, are an integral part of the Sigma 8 Pro system. These parts are mounted on the back of the panel at the construction site.

Joints

Replacing the facade panels must be a guaranteed option. Therefore, a joint width of 10 mm has been designed into the suspension system of the sub-construction. For horizontal joints, unwanted color of the background may filter through. Thermal insulation material consisting of dark glass fiber fleece with UV-resistant color counteracts this effect.

Rear ventilation

The minimum rear ventilation space is 40 mm. Construction tolerances and possible misalignment of the building must be taken into account. Horizontal profiles must not reduce the rear ventilation clearance. Thermal insulation must be secured with mechanical attachments, bonding or both.

Air intake and outlet openings

They must have a cross-section equal to at least half of the rear ventilation cross-section. Reduction of the cross-section due to ventilation profiles or similar must be taken into account.

Scaffolding

To comply with regulations, the scaffold runs must be adapted to each construction phase. Sufficient space for panel mounting must be provided between the scaffold and the facade. Scaffolding with inside brackets is recommended.

Joint putties

Before using putties or sealing compounds on Largo facade panels, the manufacturer must be consulted about their specific suitability. For example, silicone and Thiokol putties can secrete their plasticizers, which leads to contamination that cannot be removed. Swisspearl rejects any liability for such facade contamination.

Compatibility

Bare aluminum profiles (window sills, frames, etc.) are not compatible with fiber cement products. Exposed aluminum parts must be furnished in anodized or powder-coated quality with protective films for outdoor applications. Panel cutting or drilling dust in combination with moisture can cause permanent stains on the anodized surfaces.

Back of panel

The Largo facade panel comes with production and identification data on the back for quality assurance. These data can become visible with certain detail work, for example at lintels, outer corners, etc.

Building expansion

In the case of constructive expansion joints, the facade sub-constructions and cover panels must also be separated by a continuous expansion joint.

Reference values for back pressure

The general zones of the back pressure chart are divided according to the SIA standards as follows:
 0.9 kN/m², 1.1 kN/m² and 1.3 kN/m². Furthermore, the values in the transition zones of the Alps [1.1 - 3.3 kN/m²] and the Cretes and peaks in the Jura mountains [2.4 kN/m²] must be taken into account.

Definitive measurements at the construction site

The dimensions on the drawing and axes are determined in the building shell for the definitive determination of

- Sub-construction divisions
- Definitive final distance
- Window alignments
- Frames, window sills, lintels
- Horizontal and vertical connections and terminations
- Dimensions of the Largo facade panels (transfer in the order form)
- Structural conditions

Positioning

It is recommended to order the panels by their positions, in the order of their assembly sequence.
 The order form can be found at swisspearl.com.

Edge area

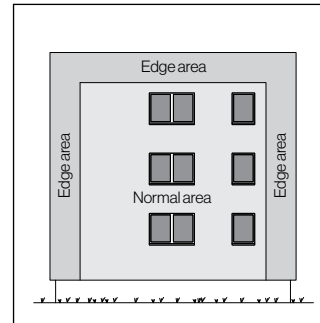

The width of the edge area corresponds to 1/10th of the facade length and facade height (min. 1.0 m max. 2.0 m).

Sub-construction types

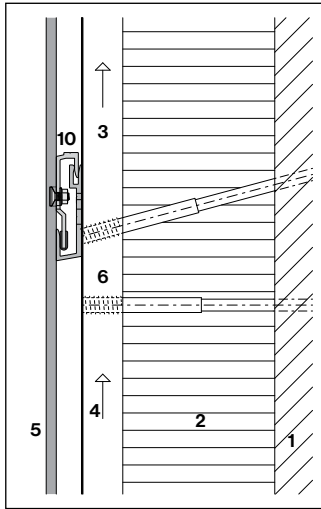

Wood/distance screw

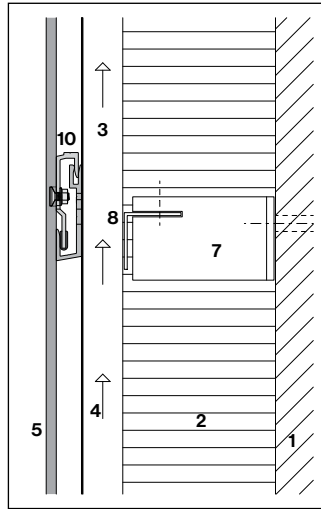

Wood/metal sub-construction
heat bridge optimized sub-construction

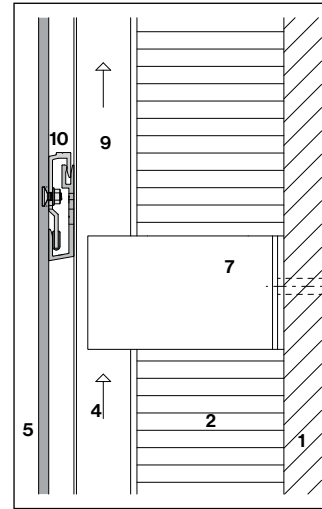

Metal sub-construction
heat bridge optimized sub-construction

- 1 Supporting structure, substrate
- 2 Thermal insulation
- 3 Vertical support slat
- 4 Rear ventilation
- 5 Largo panel 8mm
- 6 Spacer screws

- 7 Bracket with Thermostopp
heat bridge optimized bracket
- 8 Horizontal support profile
- 9 Vertical support profile
- 10 Sigma 8 Pro facade system

The Sigma 8 Pro facade system can be used with wood, spacer screws, wood-metal, light metal or heat bridge optimized sub-constructions. The design and assembly specifications as well as the structural characteristics of the sub-construction supplier must be observed.

Wood sub-construction

Unprotected horizontal wooden constructions must be avoided. In the case of wood sub-constructions or wood-element buildings, a dark facade membrane, which meets the requirements for open joint facades protection, must be installed.

Axes dimensions determination

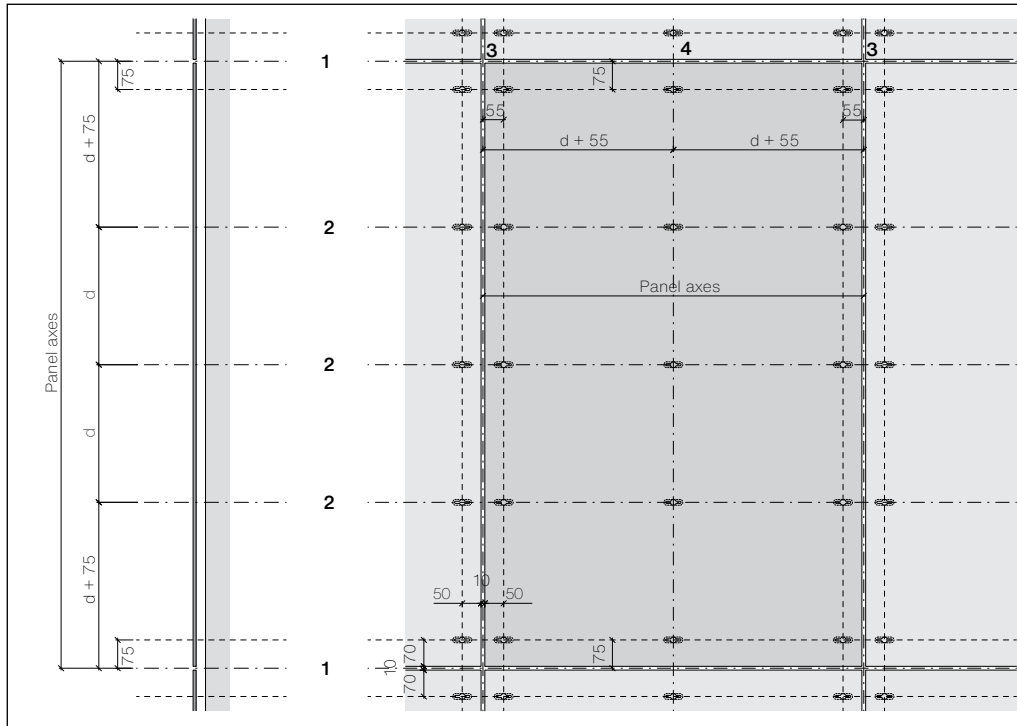

Planning aid, conciliation of horizontal and vertical axes

Edge distances

Horizontal	50 mm
Vertical	70 mm

The maximum edge distance for connections and terminations is 100 mm.

Joint width

The joint width of 10 mm is defined by the suspension system, system-dependent.

- 1 Horizontal panel axis:
Reference line for panel mounting
- 2 Horizontal dividing axes:
These correspond to the center point of the factory-side undercut hole drilling and the mounting axis for the S8 U-cleats
- 3 Vertical panel axis:
For the division of the supporting structure
- 4 Vertical axis for intermediate support

Conciliation and function of the cleat layout

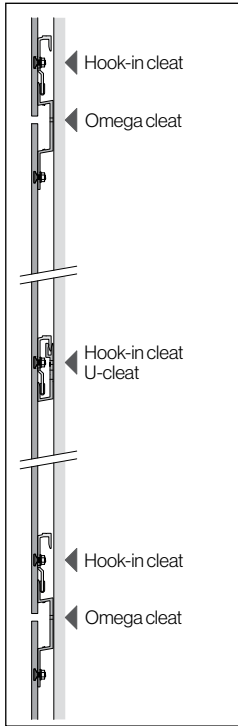

Area section

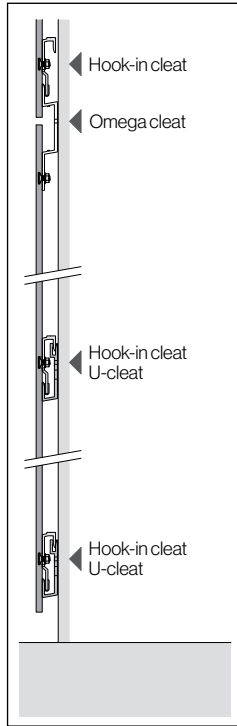

Facade base

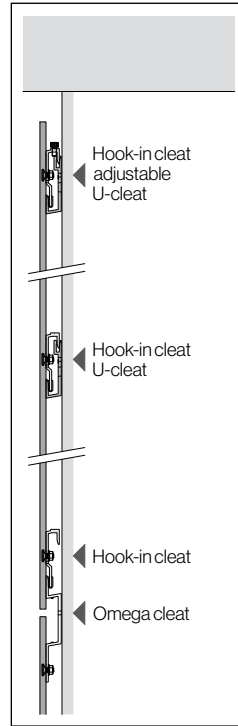

Facade termination

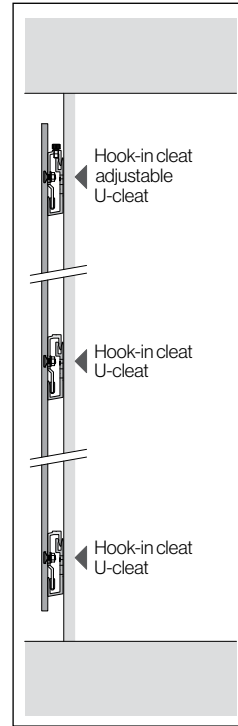

Window parapet or floor

Cleat layout

U-cleats are mounted on the support structure at each hook-in point. Fixing points in the horizontal joint area are excluded from this. At these points the panels are fixed with Omega cleats and do not require U-cleats. The Omega cleats also use the lowest hook-in points of the above-lying panel.

Layout of the suspension and Omega cleats in the facade surface area

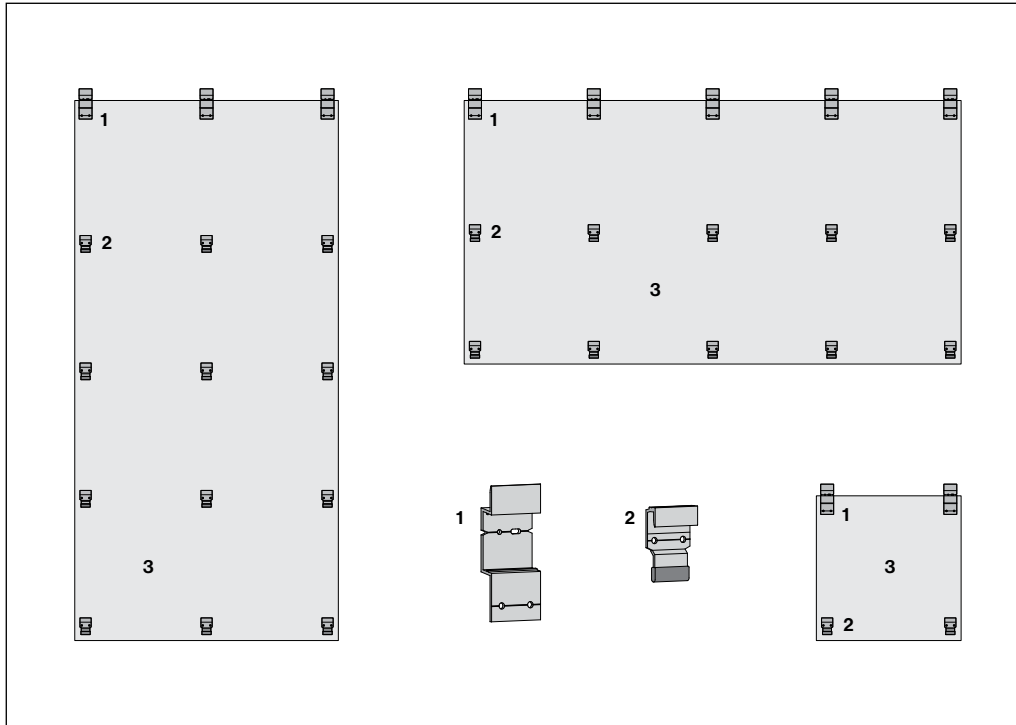

Procedure

On the back of the panels, Omega cleats are mounted on the top row; on the rows below hook-in cleats are used. The Omega cleats carry over the intrinsic loads of the panel into the sub-construction, the hook-in cleats carry the wind and suction forces. This cleat assembly excludes window parapet and facade termination panels.

Example of possible panel formats

- 1 Omega cleat S8 Pro
- 2 Hook-in cleat S8 Pro
- 3 Largo panel, 8mm

Arrangement of the hook-in cleats on the upper facade termination and on the window parapet panels

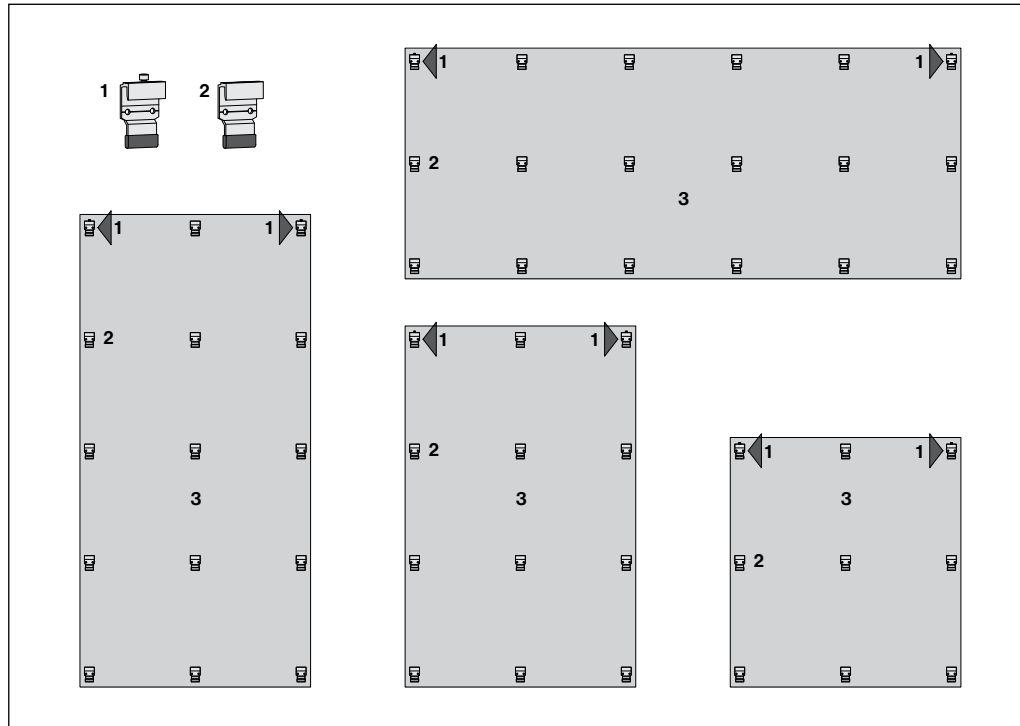

Example of possible panel formats

Procedure

In the case of facade termination and window parapet panels, hook-in cleats are mounted on the back at all fixing points. The mechanical fastening with Omega cleats is no longer possible in these areas. The panel load is carried by two hook-in cleats S8 with adjustment. The arrows mark each hook-in cleat.

- 1 Hook-in cleat S8 Pro with adjustment (arrows)
- 2 Hook-in cleat S8 Pro
- 3 Largo panel, 8mm

U-cleat and hook-in cleat with adjustment

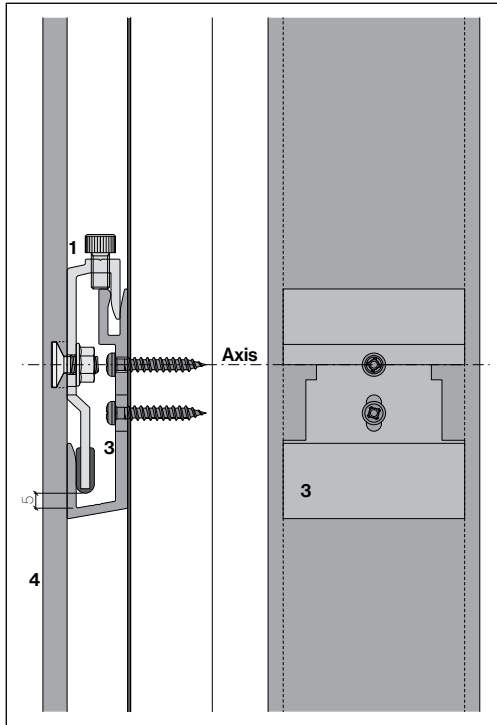

U-cleat and hook-in cleat

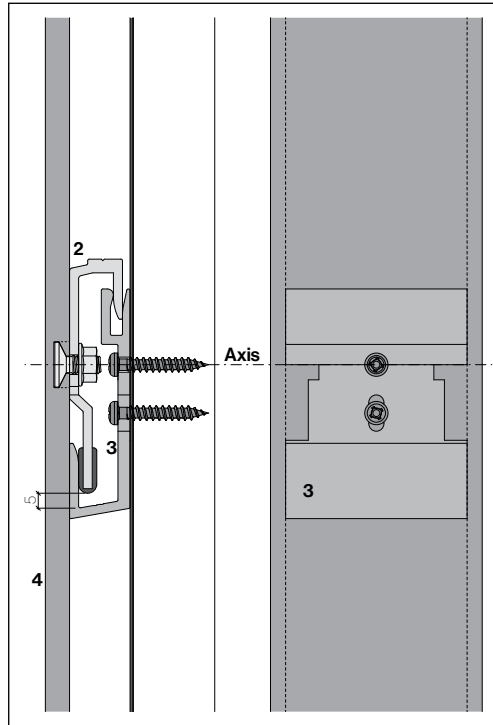

U-cleats are mounted on the support structure at each hook-in point. Fixing points in the horizontal joint area are excluded from this. At these points the panels are fixed with Omega cleats and do not require U-cleats. The horizontal dividing axis refers to the center of the rear undercut anchor / undercut hole drilling.

The hook-in cleats S8 Pro with adjustment carry the panel loads. The adjusting screws are set at the factory to 5 mm and can be adjusted (+3 mm / -4 mm) in case of inaccuracies.

The hook-in cleats S8 Pro mitigate the wind loads acting on the building structure. (wind and suction forces)

- 1 Hook-in cleat S8 Pro with adjustment
- 2 Hook-in cleat S8 Pro
- 3 U-cleat S8
- 4 Largo panel, 8mm

Suspension space

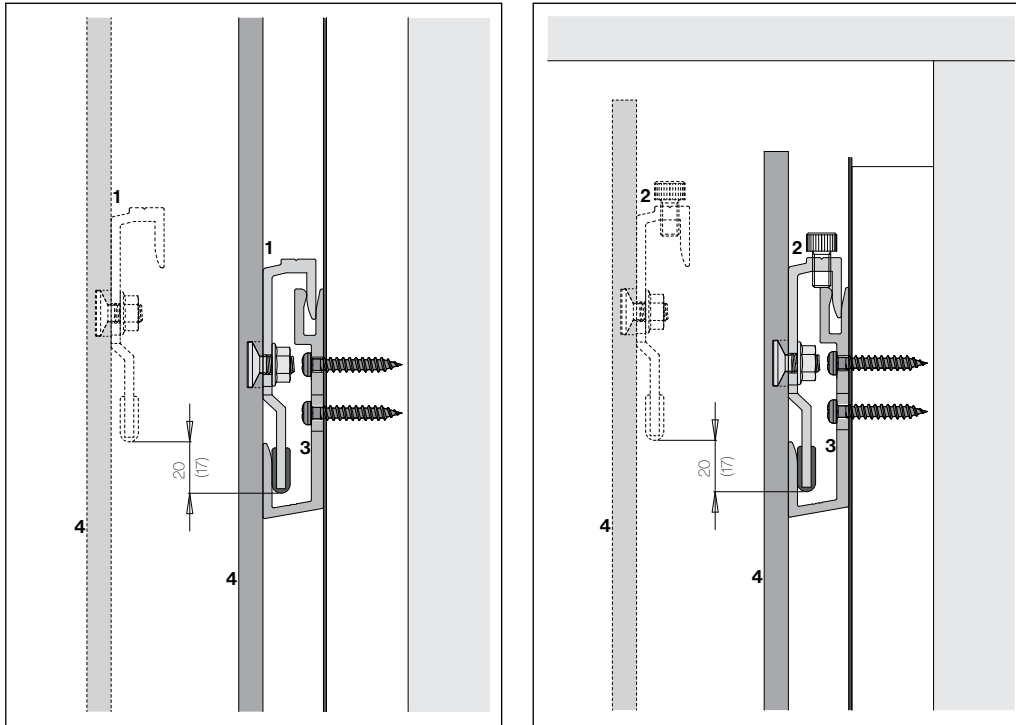

In the case of suspension systems such as Sigma 8 Pro, the suspension space must be taken into account for facade penetrations. Consider this for all cutouts such as window sills, kitchen exhausts, and various other installations, etc.

- 1 Hook-in cleat S8 Pro
- 2 Hook-in cleat S8 Pro with adjustment
- 3 U-cleat S8
- 4 Largo panel, 8 mm

The suspension space is 17 mm. To avoid constraints, 20 mm of horizontal clearance is to be calculated in.

Installation of migration protection K

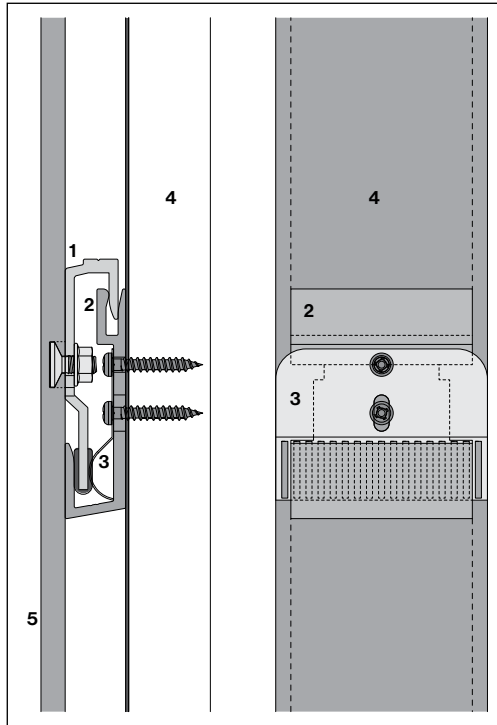
**Migration protection**

The facade termination panels and window parapet panels are not mechanically fastened by the suspensions. Migration protection is added to avoid shifting.

The panels must be aligned into the migration protection prior to mounting. Lateral shifting will then no longer be possible.

Single panel exceptions

Vertically laid single-plate panels in the facade area are mechanically fastened with two Omega cleats. Additional migration protection is applied to the second mounting row on the left or right side to avoid a migration of single-plate panels due to the unfavorable ratio of the panel height to the panel width.

- 1 Hook-in cleat S8 Pro
- 2 U-cleat S8
- 3 Position migration protection K S8
- 4 Vertical support slat
- 5 Largo panel, 8 mm

The migration protection K is mounted together with the U-cleat on the support structure.

Arrangement of the migration protection on the upper facade termination and on the window parapet panels

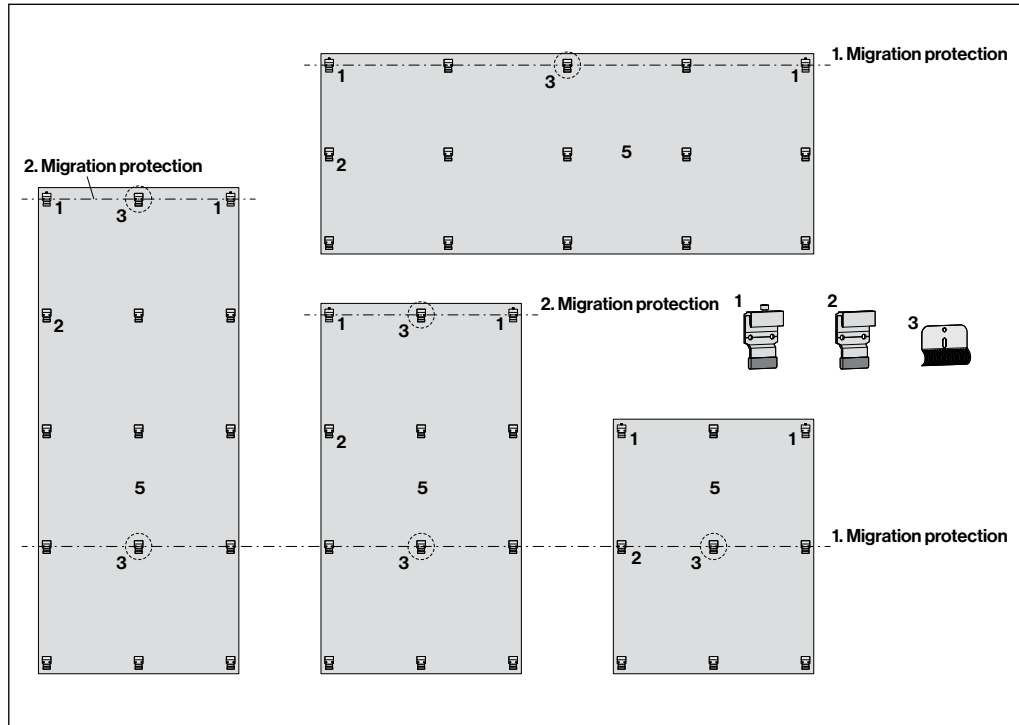

Migration protection is required for panels with two and three horizontal mounting rows.
 With four and more horizontal mounting rows, a second migration protection is required per panel.

In the single-plate panel areas

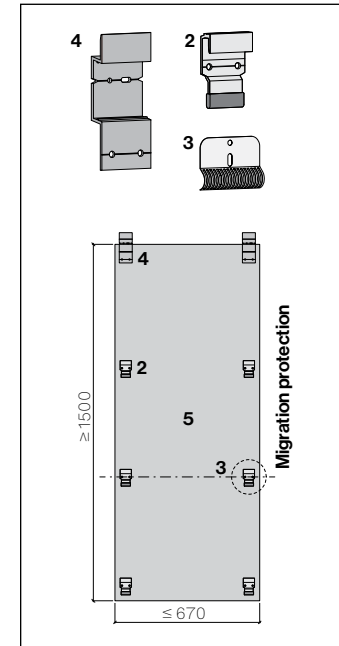

- 1 Hook-in cleat S8 Pro with adjustment
- 2 Hook-in cleat S8 Pro
- 3 Position migration protection K S8
- 4 Omega cleat S8 Pro
- 5 Largo panel, 8 mm

Axis dimensions at the cross joint

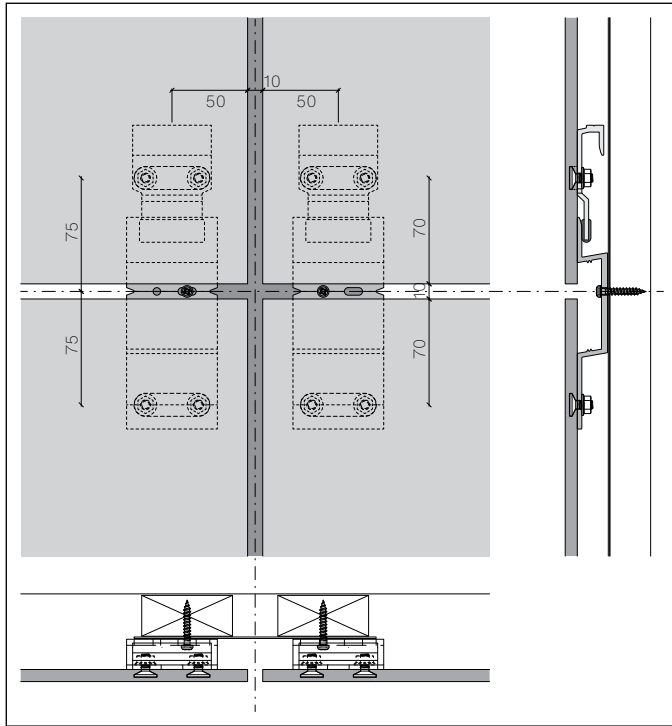

Planning aid, dimensioning of the axes at the cross joint

Axis dimensions at the facade termination

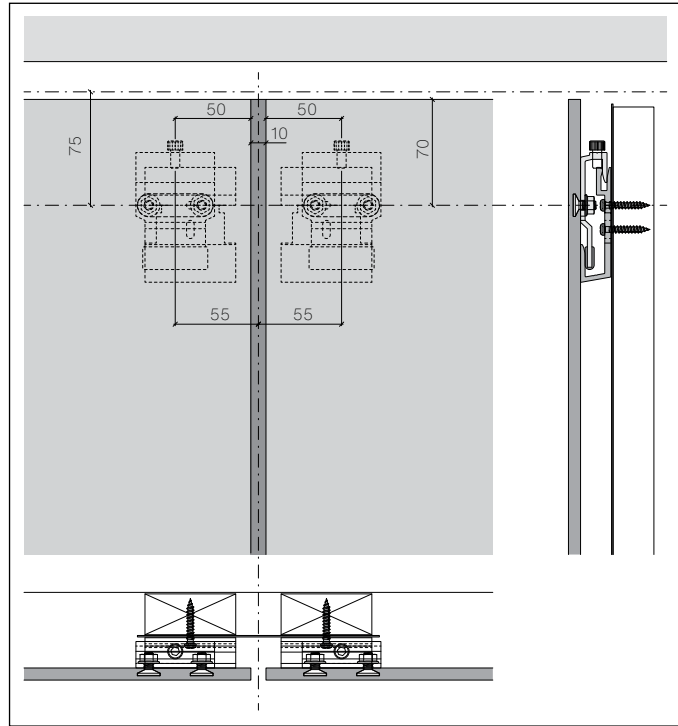

Planning aid, dimensioning of the axes at the facade termination

Axis dimensions, outer corner

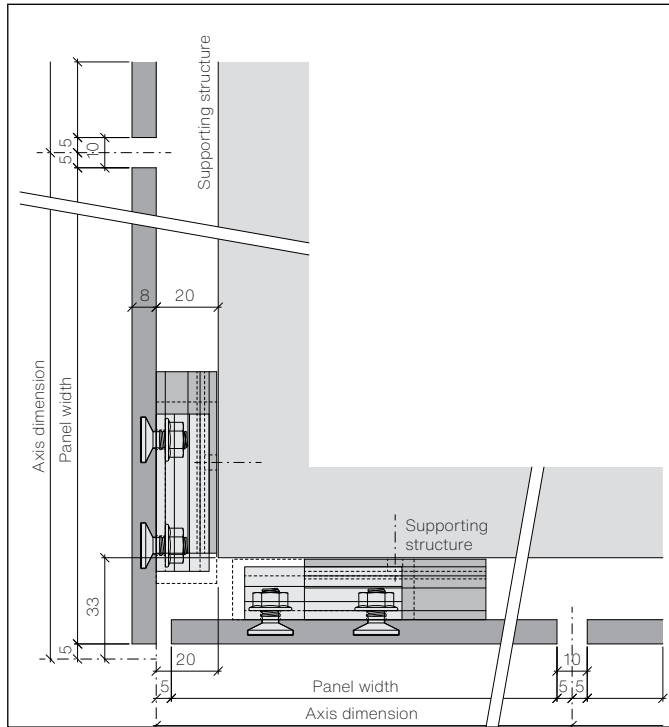

Planning aid, dimensioning of the axes at the outer corners

Axis dimensions at the inner corner

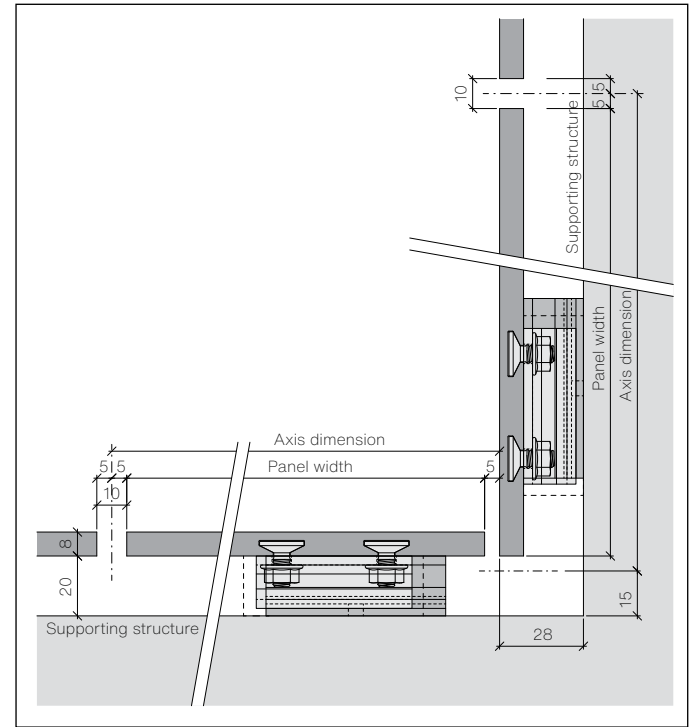

Dimensioning the axes at the inner corners

Metal and Wood sub frame - 8 mm facade panels - anchor distances

Characteristic value of wind suction (according to European standards)		Design value of wind suction (including a chosen safety coefficient of 1.5)		Recommendation for maximal spacing d (distance between anchors)			
				Vertical panel (portrait)		Horizontal panel (landscape)	
kN/m ²	psf	kN/m ²	psf	horizontally mm	vertically mm	horizontally mm	vertically mm
-0.70	-14.62	-1.00	-20.89	570	725	590	550
-1.00	-20.89	-1.50	-31.33	570	580	590	550
-1.10	-22.97	-1.60	-33.42	570	480	490	550
-1.30	-27.15	-1.90	-39.68	570	420	590	380
-1.50	-31.33	-2.20	-45.95	380	580	590	380
-1.80	-37.59	-2.70	-56.39	380	480	490	380
-2.00	-41.77	-3.00	-62.66	380	480	490	380

Metal sub frame - 8 mm facade panels

Engineering responsibility

The spacings in above table are provided as indication. For the actual cladding design a locally licensed engineer shall assume responsibility for calculation and verification.

Panel data

- Modulus of elasticity
MOE ca. 15'000 MPa
- Modulus of rupture (characteristic)
MOR (average) > 22 MPa
- Design value bending resistance 8.0 MPa (2.5 safety factor)
- Density > 1.75 g/cm³

Results after testing according to EAD 330030-00-0601, August 2018 „Fastener of external wall claddings“

Fixation system: Swisspearl Largo, tnom = 8 mm fastened with Sigma 8 Pro

Tensile failure of anchor	Rk	fastener distance
without bending l_{sup} 135 mm	1165 N	340 mm
with bending impact l_{sup} 225 mm	975 N	560 mm
with bending impact l_{sup} 300 mm	565 N	750 mm
Shear loading		
	1965 N	
Combined shear and tension 30°		
	2045 N	

l_{sup} = distance of support to consider bending of panel, corresponds with fastener distance

All values of loadability are determined externally by the test institute MPA Hannover. All values of loadability Rk are provided as 5 % fractile values (sample size: 10 specimens).

The given values of loadability shall not be used in the design. Before using in static calculations the given values of loadability shall be transformed into design values considering the local safety requirements of building object.

Sigma 8 Pro, vertical

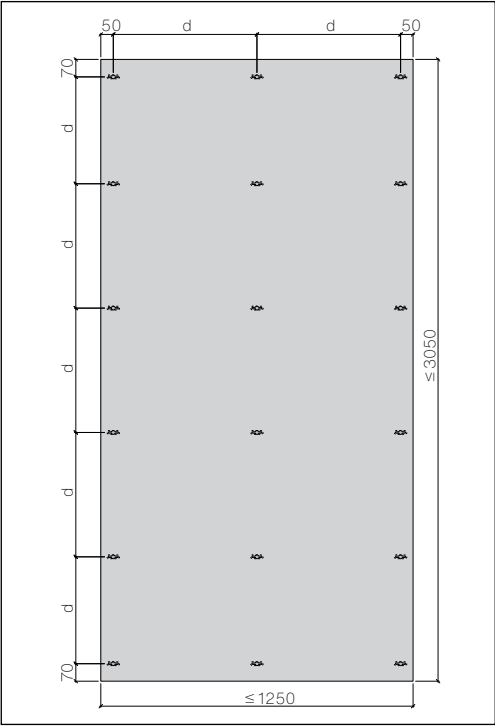

Sigma 8 Pro, horizontal

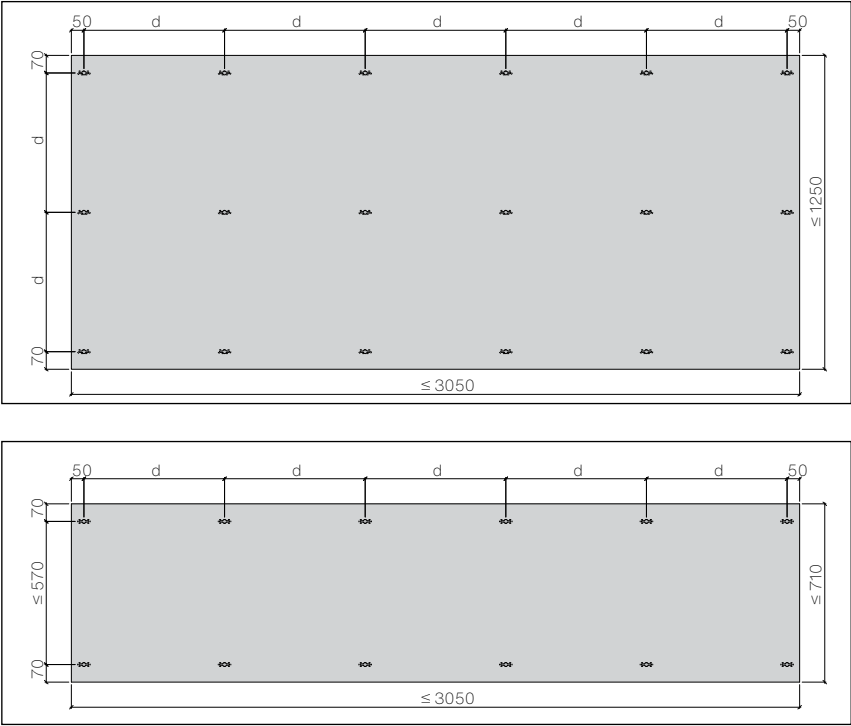

Guide values for maximum mounting distances [d] in mm for two- and multi-plate facade panels.

Single-plate panel

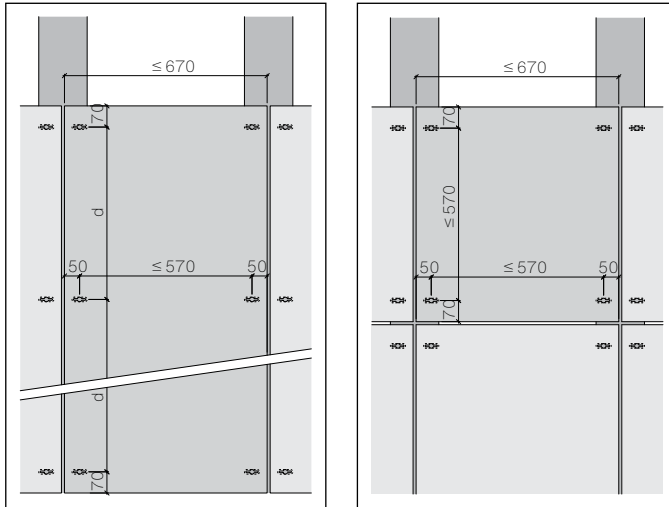

The maximum mounting distance of the single-plate panels is 570 mm. If smaller values result from the determination of the maximum fastening distances, these must be used.

Sigma 8 Pro strips installed horizontally

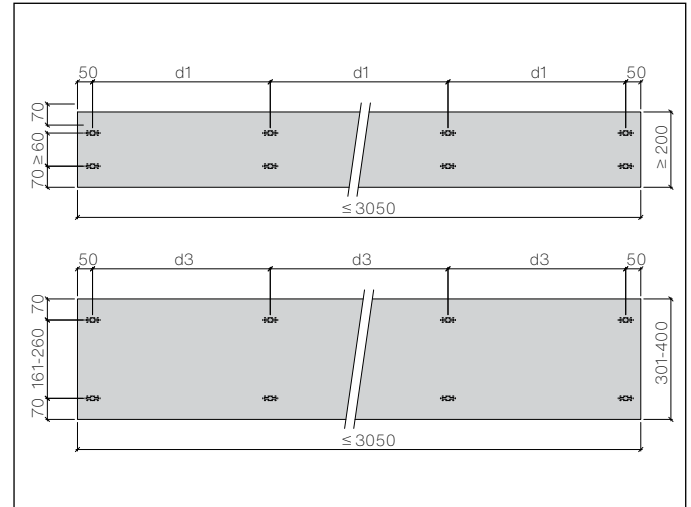

For horizontal strips, the system-based minimum panel height in the area is 200 mm. The minimum panel height for all edge panels, such as at the facade termination or under window sills, is 250 mm.

Sigma 8 Pro strips installed vertically

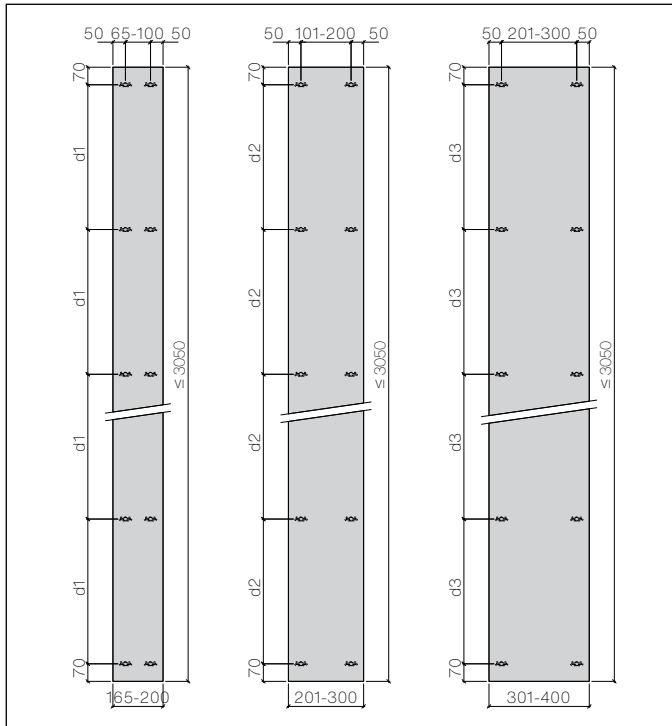

Maximum mounting distances for strips/window jambs

Wind pressure/wind suction q_{po} - Wind speed v .			10.9 kN/m ² - 1.3 kN/m ² 138 km/h - 165 km/h		
Building height in [m]			≤ 8	≤ 15	≤ 30
Strip width [mm]	165-200	d1	500	500	500
	201-300	d2	570	550	500
	301-400	d3	600	550	500

Mounting distances for Largo strips mounted horizontally or vertically.

For vertically installed strips, the system-based min. panel width is 165 mm.

Installation instructions

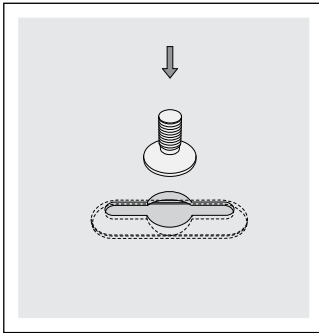

Sigma 8 Pro undercut hole drilling is done at the Swisspearl plant.

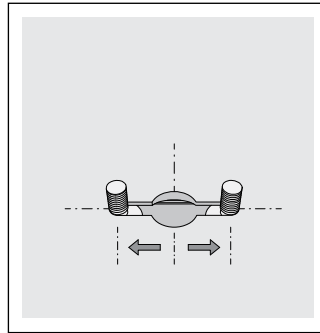

The two threaded S8 Pro anchors are inserted individually into the undercut hole drilling and moved to the side edge.

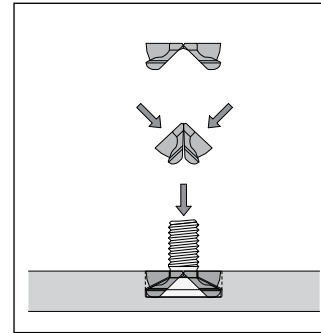

The S8 Pro spacer is pressed together and inserted into the undercut hole drilling, between the two threaded anchors. Press to spread out the S8 Pro spacer again.

Spacer elements shall be inserted manually without impact. The use of hammers or any excessive force during installation is strictly prohibited.

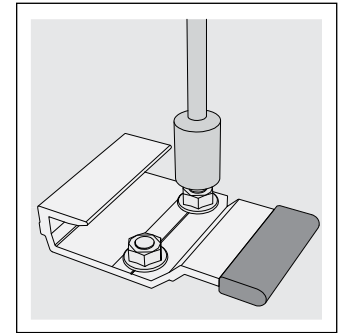

Attach the suspension and/or Omega cleats.

Must be done with a torque wrench
Tightening torque 2.5 Nm.

After the cleat assembly, the panels are immediately suspended and fastened to the sub-construction without any intermediate storage. The installation is done from the bottom to the top.

Horizontal joint sheet (optional)

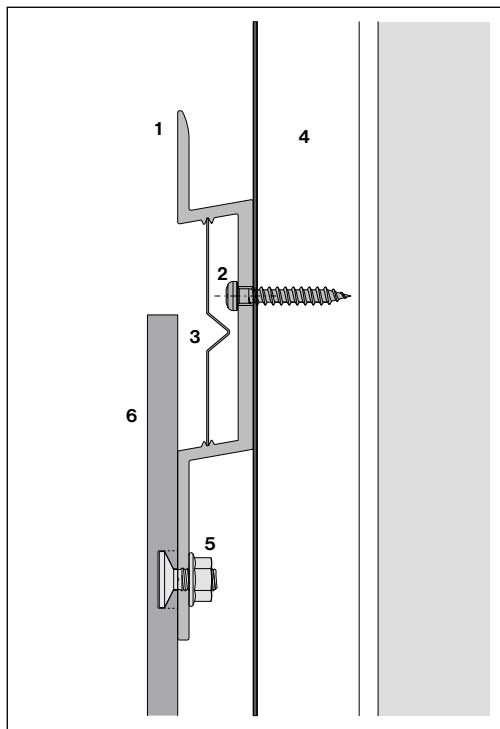

Horizontal joint sheet - aluminum 0.5 mm, black, powder coated.

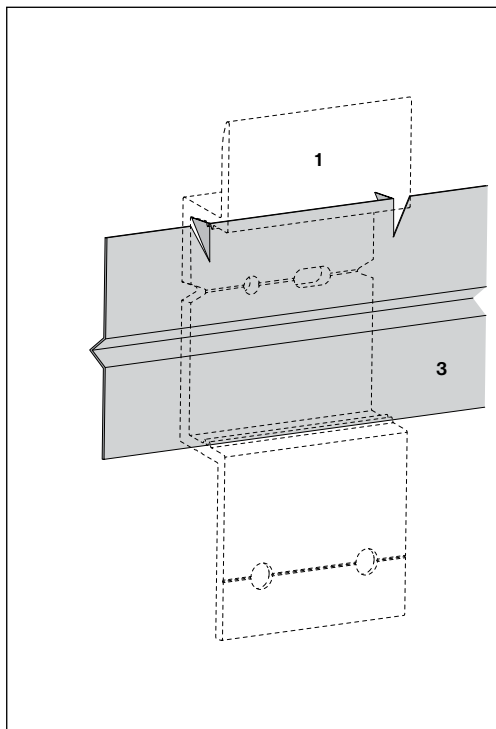

Slitting and bending prevents the horizontal joint sheets from migrating.

The horizontal joint sheet is cut to the panel width minus 2 mm and clicked into the guide grooves of the Omega-cleats. Slitting and bending prevents the horizontal joint sheets from migrating. On-site replacement of defective panels will no longer be possible due to the continuous horizontal joint sheet. Disassembly of several panels will be required.

Special order on request, the item is not in the standard assortment!

- 1 Omega cleat S8 Pro
- 2 Attachment
- 3 Horizontal joint sheet - aluminum 0.5 mm, black, powder coated, lengths 3050 mm and 2510 mm
- 4 Vertical support slat
- 5 Sigma 8 Pro system anchor
- 6 Largo panel 8 mm

Support slats

For the vertical expansion joint:

- Support slats, vertical
2 × 27 × 60 mm, with a distance of 30 mm.

For the intermediate support:

- Support slats 1 × 27 × 60 mm.

All support slats must be planed on one side and meet the following requirements:

- Thickness min. 27 mm
- Strength class II (FK II/C24)
- Wood moisture max. 20 m-%

Fasteners

For a slat width of 60 mm one screw is required for each mounting location.

Vertical joints

In the case of vertical expansion joints, inner corners and outer corners, the wooden sub-construction, including intermediate supports, must be protected against moisture by means of EPDM tape over the entire width of the slats. The lateral overhang is 5 mm.

Attaching the cleats

SR2 S8 stainless screws, Inox for wood sub-constructions, screw head Ø 8.0 mm, 4.8 × 30 mm, black, powder-coated

Mounting U-cleat on intermediate support

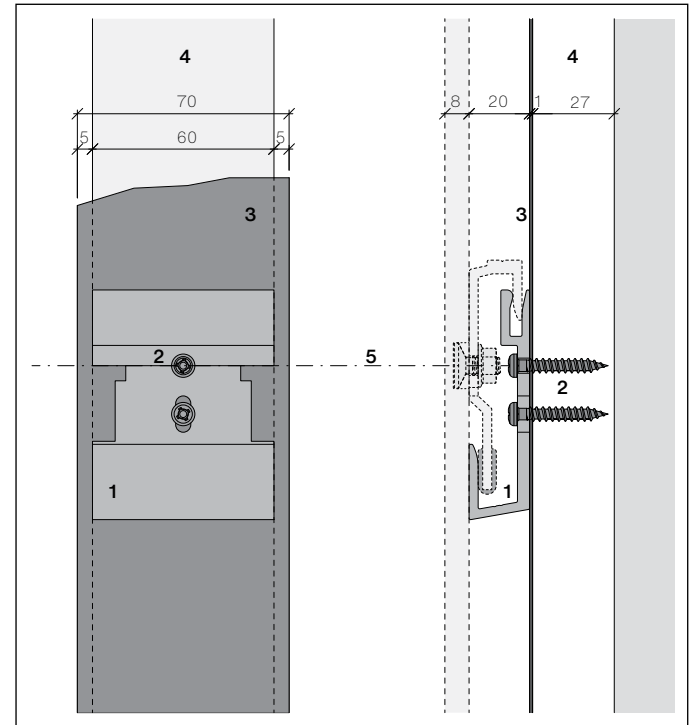

- 1 U-cleat S8
- 2 SR2 S8 screws, 4.8 × 30 mm
- 3 EPDM tape S8 70 mm
- 4 Support slat, vertical, 27 × 60 mm
- 5 Horizontal axis

Attachment: 2 SR2 S8 screws, 4.8 × 30 mm per U-cleat

Assembly of U-cleat at the vertical expansion joint

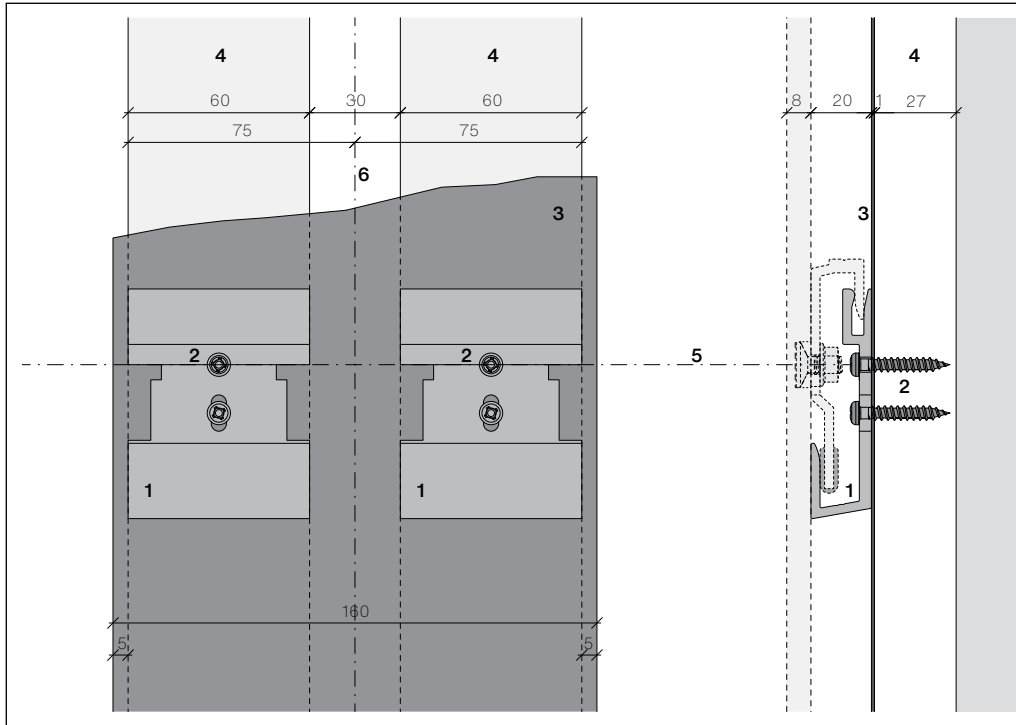

- 1 U-cleat S8
- 2 SR2 S8 screws, 4.8 × 30 mm
- 3 EPDM joint tape S8 160 mm
- 4 Support slat, vertical, 27 × 60 mm
- 5 Horizontal axis
- 6 Vertical axis

Attachment: 2 SR2 S8 screws, 4.8 × 30 mm per U-cleat

Mounting of Omega cleat on intermediate support

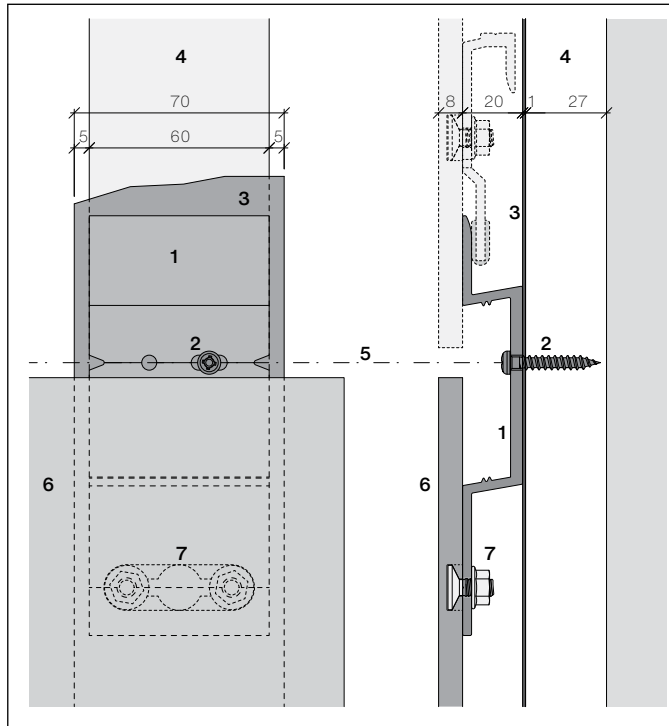

- 1 Omega cleat S8 Pro
- 2 SR2 S8 screws, 4.8×30 mm
- 3 EPDM tape S8 70 mm
- 4 Support slat, vertical, 27×60 mm
- 5 Horizontal axis
- 6 Largo panel 8 mm
- 7 Sigma 8 Pro system anchor

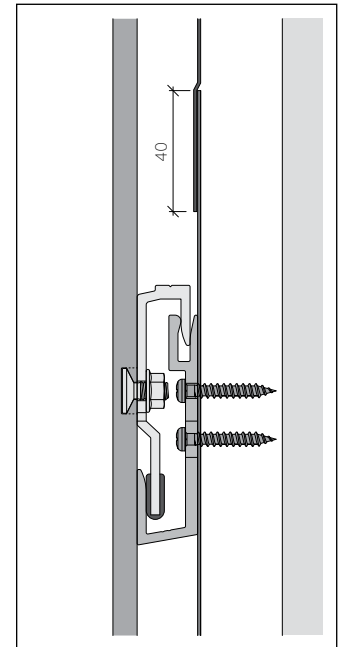

The EPDM joint tapes can be overlapped between the cleats. Minimum overlap length 40 mm.

Attachment: 1 screw SR2 S8, 4.8×30 mm into the slotted hole
[GP=SP=Sliding point]

Assembly of Omega cleat at the vertical expansion joint

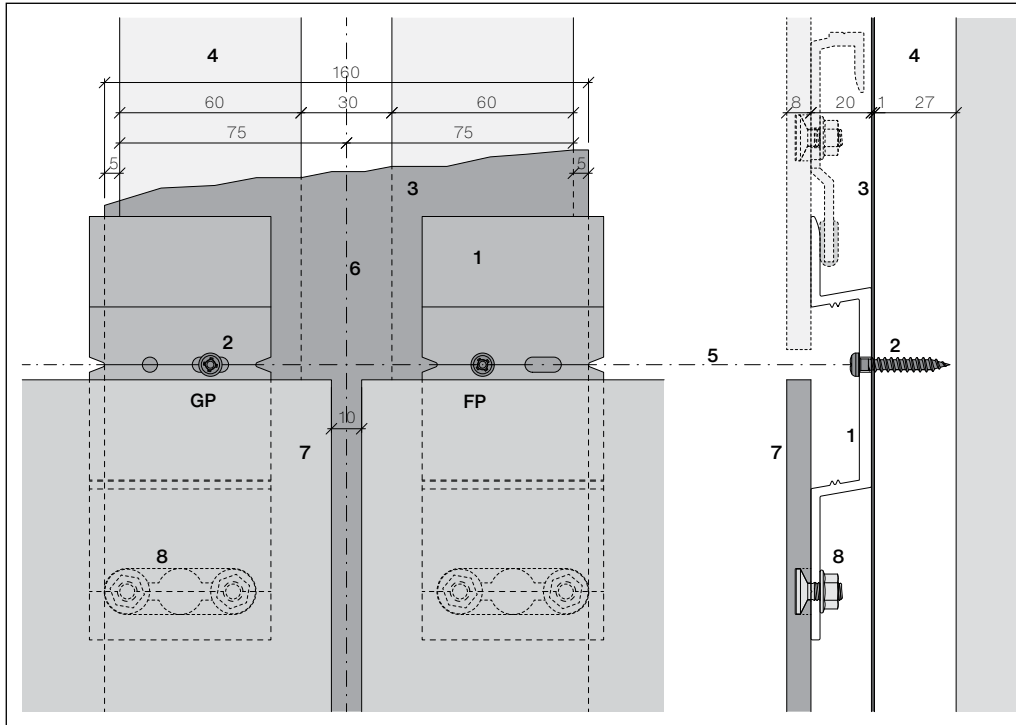

- 1 Omega cleat S8 Pro
- 2 SR2 S8 screws, 4.8×30 mm
- 3 EPDM joint tape S8 160 mm
- 2 Support slat, vertical, 2×27×60 mm
- 5 Horizontal axis
- 6 Vertical axis
- 7 Largo panel 8 mm
- 8 Sigma 8 Pro system anchor

Left Omega cleat attachment: 1 screw SR2 S8, 4.8×30 mm into the slotted hole [GP=SP=Sliding point]

Right Omega cleat attachment: 1 screw SR2 S8, 4.8×30 mm into the round hole [FP=Fix-point]

Outer corner

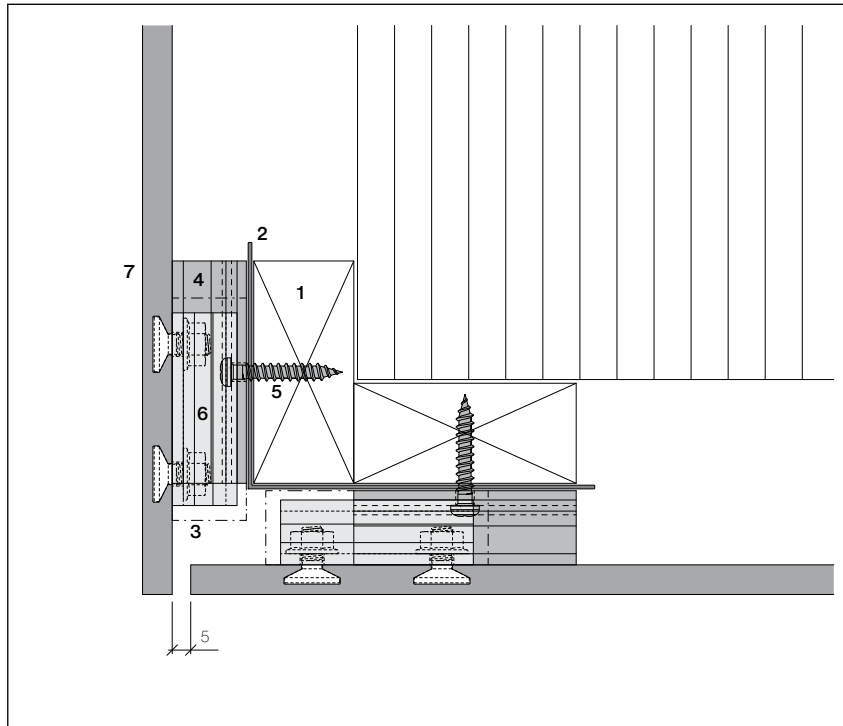

- 1 Support slat, vertical, 27 × 60 mm
- 2 EPDM joint tape S8 160 mm
- 3 Position Omega cleat S8 Pro (dash point line)
- 4 U-clip S8
- 5 SR2 S8 screws, 4.8 × 30 mm
- 6 Hook-in cleat S8 Pro
- 7 Largo panel 8 mm

The arrangement of the corner support slats depends on the vertical joint alignment

Mount U-clip on the slat alignment with two SR2 S8, 4.8 × 30 mm screws each.

Inner corner

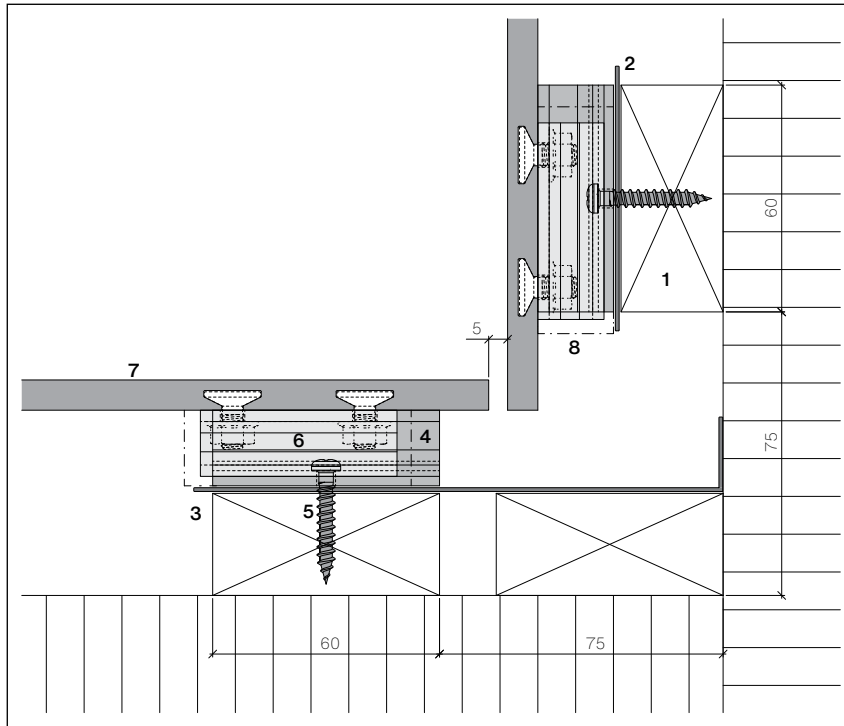

- 1 Support slat, vertical, 27 × 60 mm
- 2 EPDM tape S8 70 mm
- 3 EPDM joint tape S8 160 mm
- 4 U-cleat S8
- 5 SR2 S8 screws, 4,8 × 30 mm
- 6 Hook-in cleat S8 Pro
- 7 Largo panel 8 mm
- 8 Position Omega cleat S8 Pro
(dash point line)

Mount U-cleat on the slat alignment with two SR2 S8, 4,8 × 30 mm screws each.
Place an additional 27 × 60 mm slat in the inner corner.

Window frame, horizontal section

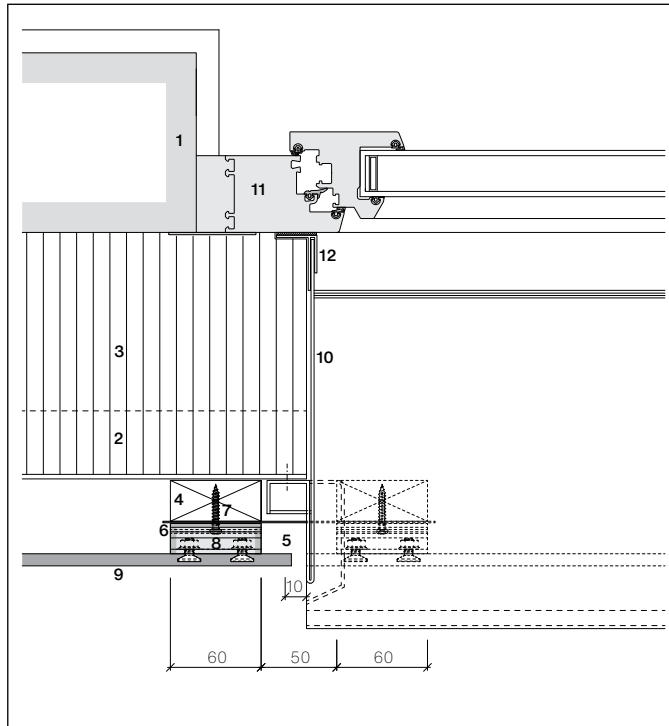

- 1 Substrate, supporting structure
- 2 Sub-construction
- 3 Thermal insulation
- 4 Support slat, vertical, 27 × 60 mm
- 5 EPDM joint tape S8 180 mm
- 6 U-cleat S8

Window frame, vertical section

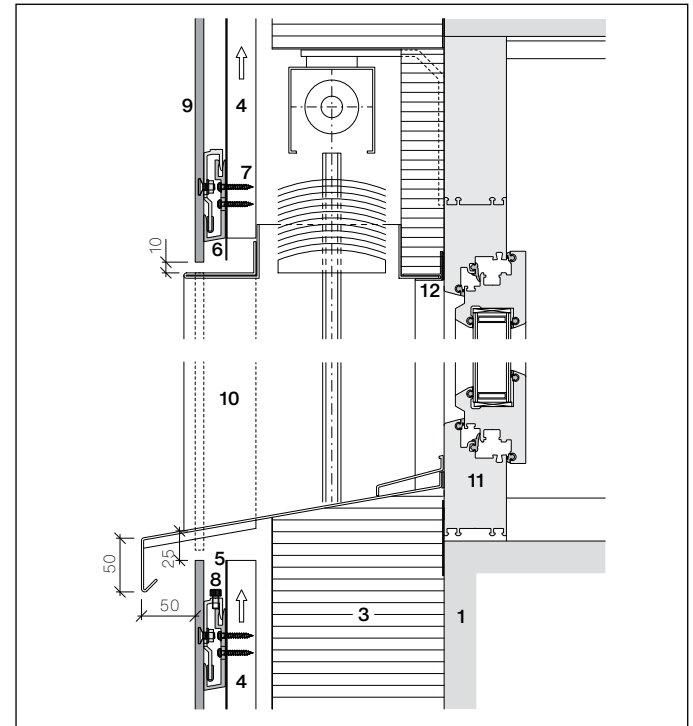

- 7 SR2 S8 screws, 4.8 × 30 mm
- 8 Hook-in cleat S8 Pro (with adjustment)
- 9 Largo panel 8 mm
- 10 Frame
- 11 Window
- 12 F-profile with seal

Window sill

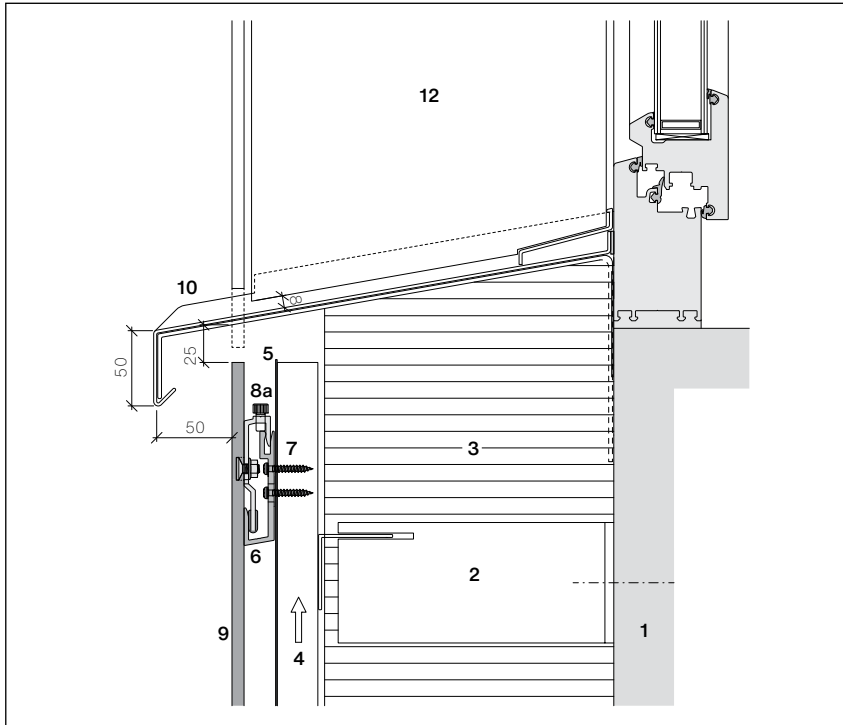

The 20 mm hook-in distance must be strictly observed!
The joint between the window jamb and the window sill is 8 mm.

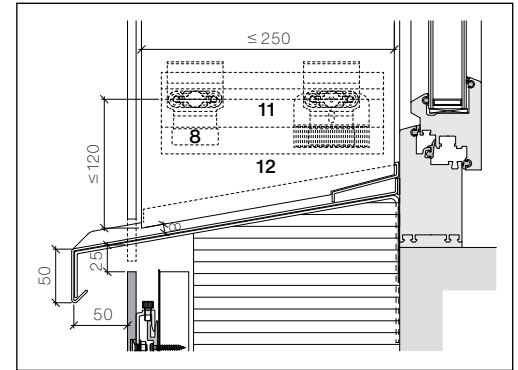

The maximum vertical mounting distance of 100 mm may be increased to 120 mm at the window jamb. For window jamb widths over 250 mm, the lower hook-in points must be offset in height.

- 1 Substrate, supporting structure
- 2 Sub-construction
- 3 Thermal insulation
- 4 Support slat, vertical, 27 × 60 mm
- 5 EPDM joint tape S8
- 6 U-cleat S8
- 7 SR2 S8 screws, 4.8 × 30 mm
- 8 Hook-in cleat S8 Pro(8a with adjustment)
- 9 Largo panel 8 mm
- 10 Window sill
- 11 U-profile rod S8, black anodized,
- 12 Largo window jamb panel

Lintel

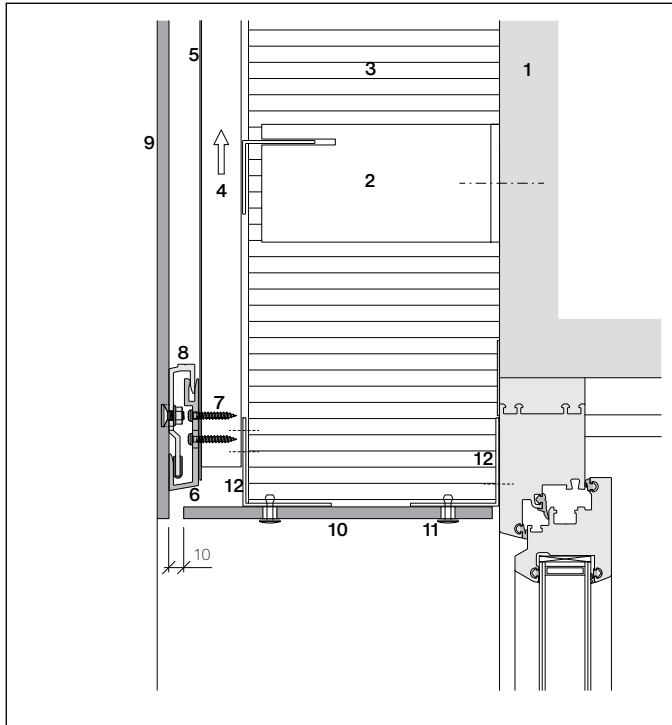

- 1 Substrate, supporting structure
- 2 Sub-construction
- 3 Thermal insulation
- 4 Support slat, vertical, 27 × 60 mm
- 5 EPDM joint tape S8
- 6 U-clip S8
- 7 SR2 S8 screws, 4.8 × 30 mm
- 8 Hook-in cleat S8 Pro
- 9 Largo panel 8 mm
- 10 Largo lintel panel 8 mm, attachment is visible, with fix and sliding points
- 11 Facade rivet AIMg, 4.0 × 18-K15, attachment with anchor and sliding points
- 12 Aluminum angle

Sub-construction for lintel

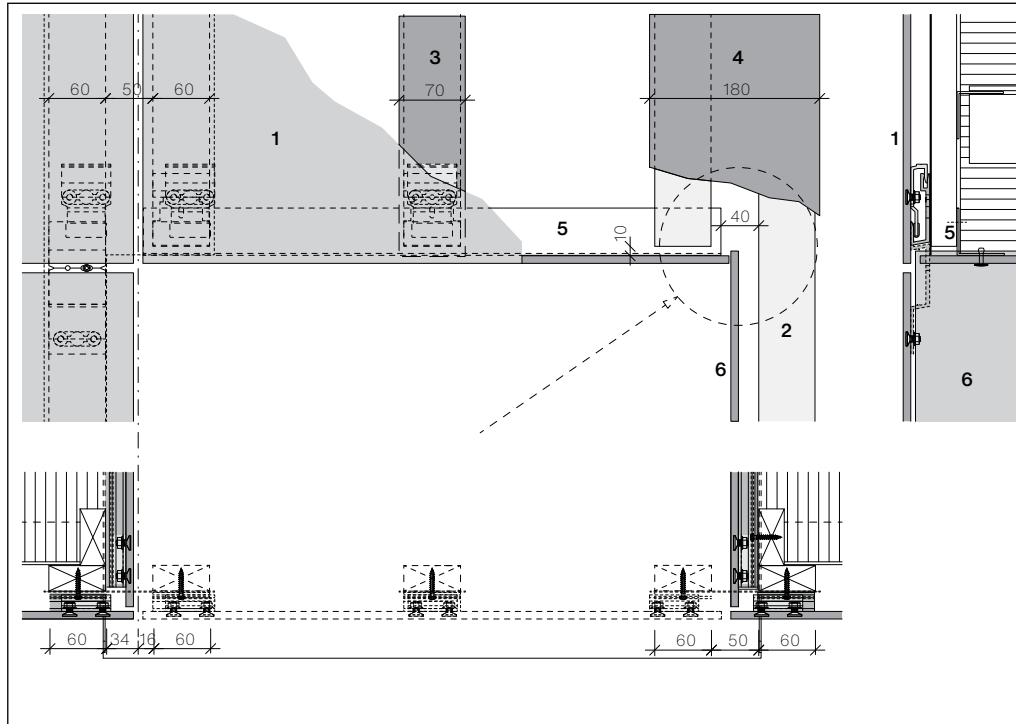

- 1 Largo panel 8 mm
- 2 Support slat, vertical, 27 × 60 mm
- 3 EPDM tape S8 70 mm
- 4 EPDM joint tape S8 180 mm
- 5 Aluminum angle
- 6 Largo window jamb panel 8 mm

In order to allow the window jamb to be suspended, the header sub-construction must have a distance of 40 mm from the window jamb sub-construction.

Lintel with blind casing

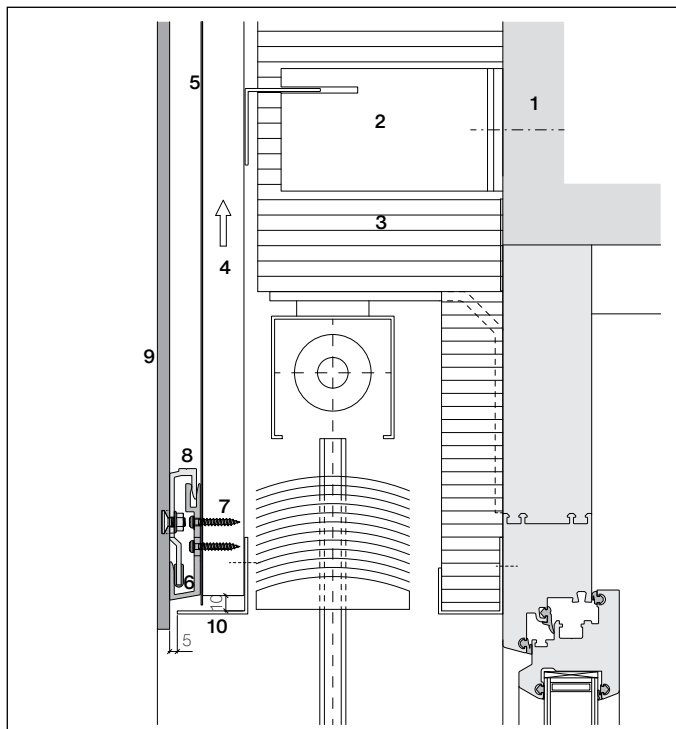

- 1 Substrate, supporting structure
- 2 Sub-construction
- 3 Thermal insulation
- 4 Support slat, vertical, 27 × 60 mm
- 5 EPDM joint tape S8
- 6 U-cleat S8
- 7 SR2 S8 screws, 4.8 × 30 mm
- 8 Hook-in cleat S8 Pro
- 9 Largo panel 8 mm
- 10 Aluminum reinforcement profile, coated

Version with U-cleats, mounted on slatting

Roof edge

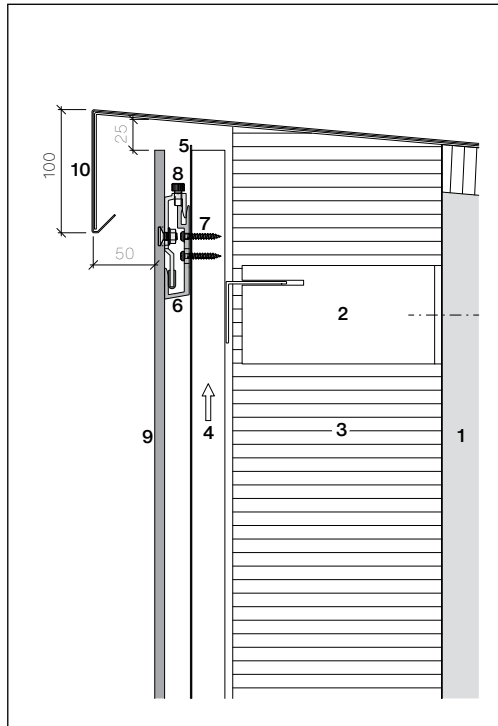

Roof edge termination

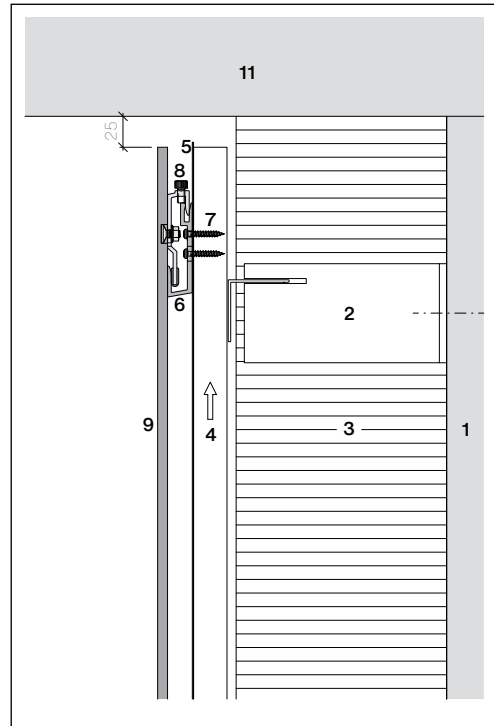

Connection at the soffit

- 1 Substrate, supporting structure
- 2 Sub-construction
- 3 Thermal insulation
- 4 Support slat, vertical, 27 × 60 mm
- 5 EPDM joint tape S8
- 6 U-clip S8
- 7 SR2 S8 screws, 4.8 × 30 mm
- 8 Hook-in cleat S8 Pro with adjustment
- 9 Largo panel 8 mm
- 10 Roof edge cover
- 11 Soffit

The 20 mm hook-in distance must be strictly observed.

Base connection

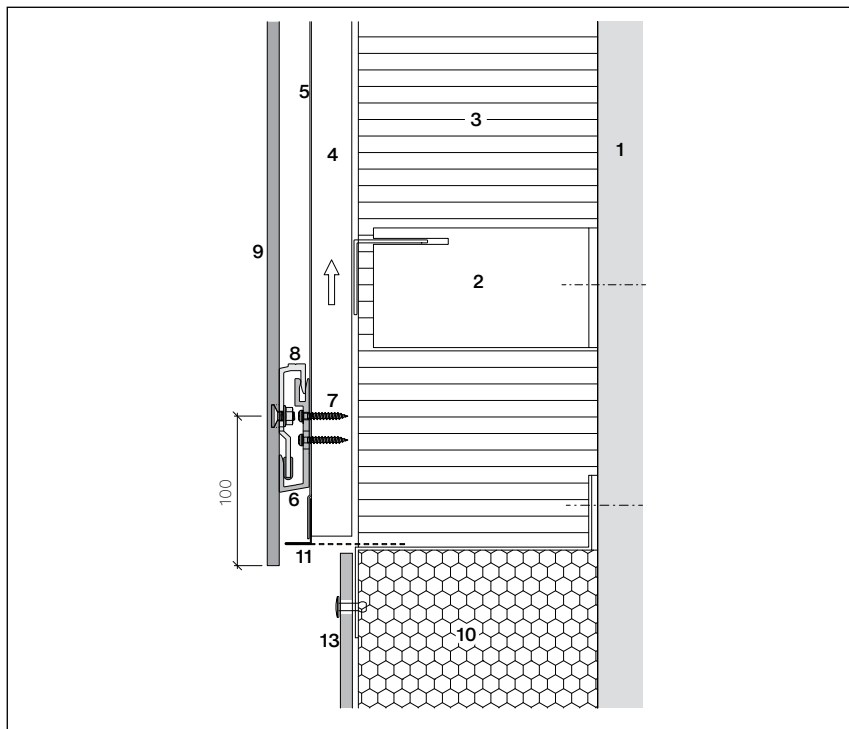

The vertical bottom edge distance must be 100 mm when using the partially perforated S8 ventilation profile.

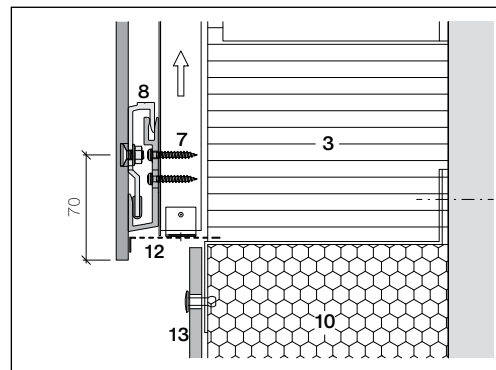

Design solution variant with ventilation profile, on site, with vertical margin distance of 70 mm (standard).

- 1 Substrate, supporting structure
- 2 Sub-construction
- 3 Thermal insulation
- 4 Support slat, vertical, 27 × 60 mm
- 5 EPDM tape/joint tape S8
- 6 U-cleat S8
- 7 SR2 S8 screws, 4.8 × 30 mm
- 8 Hook-in cleat S8 Pro
- 9 Largo panel 8 mm
- 10 Perimeter insulation
- 11 Ventilation profile S8
- 12 Ventilation profile, on site
- 13 Base panel
(construction panel Plus/Largo)

Light metal sub-construction supporting profiles

The sub-construction must be as high as the building story: profile length max. 3 m (thickness ≥ 2.0 mm). A T-profile of min. $140 \times 45 \times 2$ mm and for the intermediate support, an angle profile of min. $45 \times 45 \times 2$ mm is required below where the panels meet.

Steel sub-construction

Steel profiles, galvanized steel S 235 or Inox V2A. The length of the profiles in a vertical arrangement must not exceed 6 m (thickness ≥ 1.5 mm). A minimum contact surface of 140 mm where the panels meet and 45 mm for the intermediate support are required for steel sub-constructions.

The connection of individual panels beyond where horizontal or also vertical supports/supporting profiles meet can lead to uncontrolled constraints, independent of a steel or light metal sub-construction.

Compatibility of metallic materials

The anodizing of the cleats serves as a separating layer for the assembly on steel sub-constructions. For steel sub-constructions, it should be noted that drilling chips can cause rust bloom on third-party components.

Rivet

Rivets for aluminum and steel sub-constructions, Inox, rivet head $\varnothing 9.0$ mm, 4.8×12 -K9.0 mm, black, powder-coated grip length 5.5-8.0 mm.

Bore holes in light metal or steel

Drill bit $\varnothing 4.9$ mm

- 1 U-cleat S8
- 2 Rivets S8 4.8×12 -K9.0 mm
- 3 Support profile, vertical, Alu, $45 \times 45 \times 2$ mm
- 4 Horizontal axis

Mounting U-cleat on intermediate support

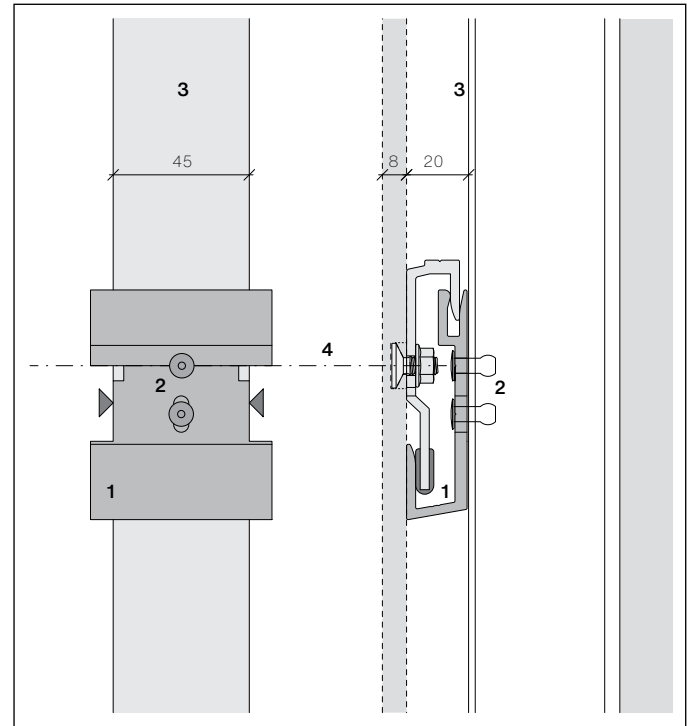

Attachment: 2 rivets per U-cleat, 4.8×12 -K9.0 mm
Remove drill chips from the U-cleats

Assembly of U-cleat at the vertical expansion joints

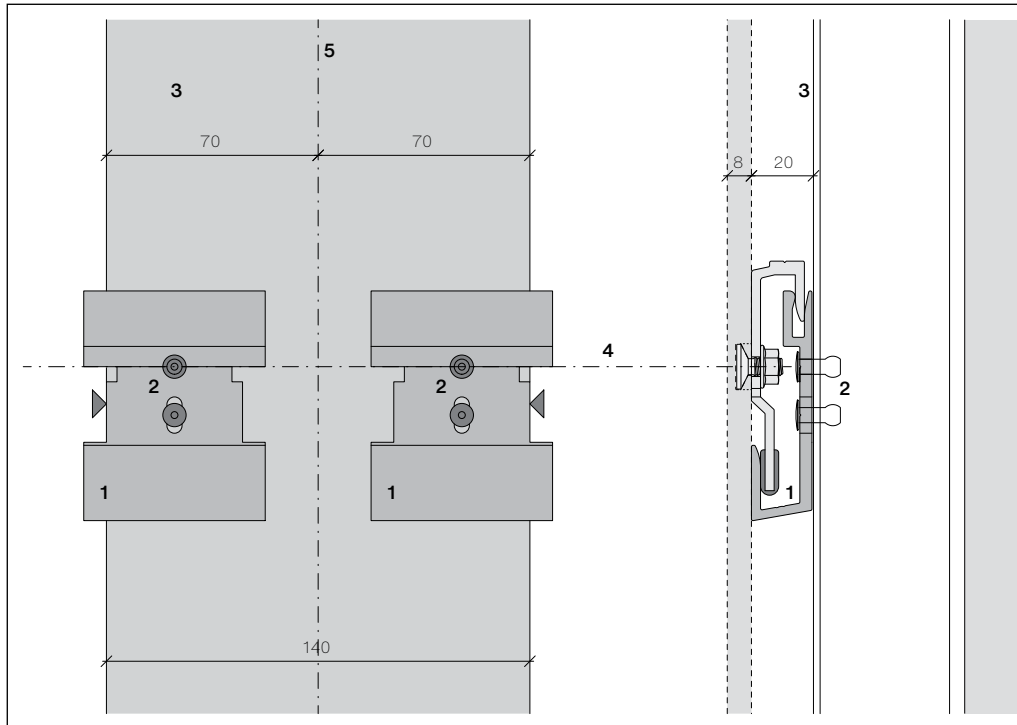

Note for Gesipa-AccuBird® blind rivet driving tool

The standard receiving container of the Gesipa-AccuBird® accepts broken off plug rivets up to a length of 65 mm. For the rivet-S8 with special mandrel (78 mm), the receiving container must be extended. This is possible by inserting an extension part (28 mm). It can be ordered from Swisspearl.

- 1 U-cleat S8
- 2 Rivets S8 4.8×12-K9.0 mm
- 3 Support profile,
Alu T-profiles × 45 × 2 mm,
black in the joint area
- 4 Horizontal axis
- 5 Vertical axis

Attachment: 2 rivets per U-cleat S8 4.8×12-K9.0 mm
Remove drill chips from the U-cleats

Mounting of Omega cleat on intermediate support

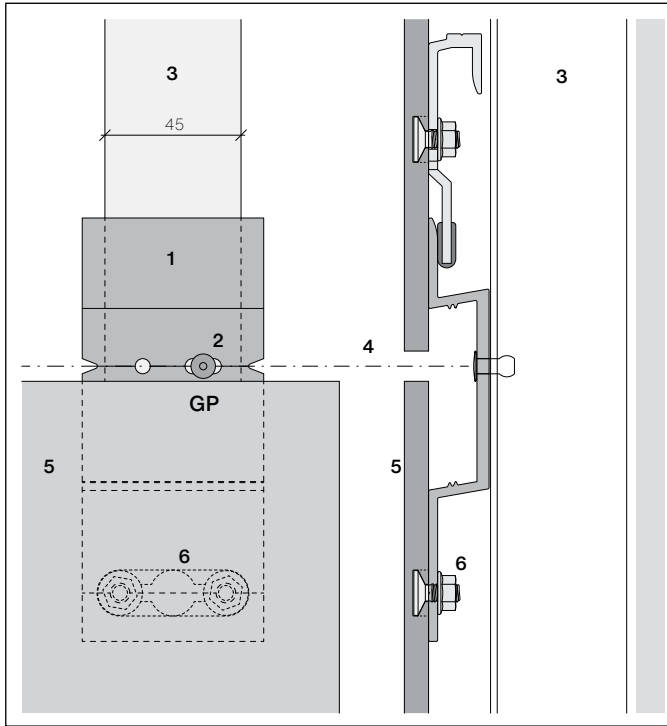

- 1 Omega cleat S8 Pro
- 2 Rivets S8 4.8×12-K9.0 mm
- 3 Support profile, Alu 45×45×2 mm
- 4 Horizontal axis
- 5 Largo panel 8 mm
- 6 Sigma 8 Pro system anchor

Attachment: 1 Rivet 4.8×12-K9.0 mm into the slotted hole [SP=Sliding point]

Profile separation

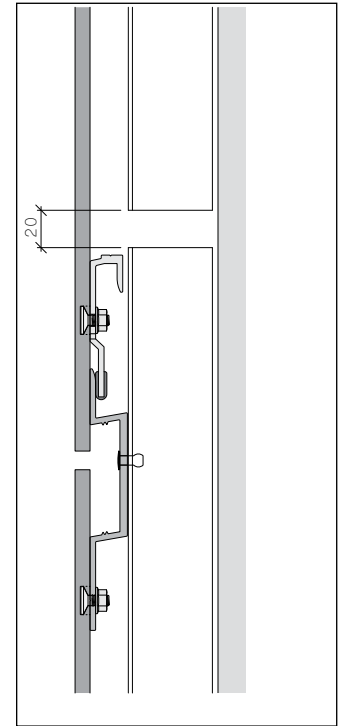

The joints of vertical support profiles may only be located above the Omega cleats.

Assembly of Omega cleat at the vertical expansion joint

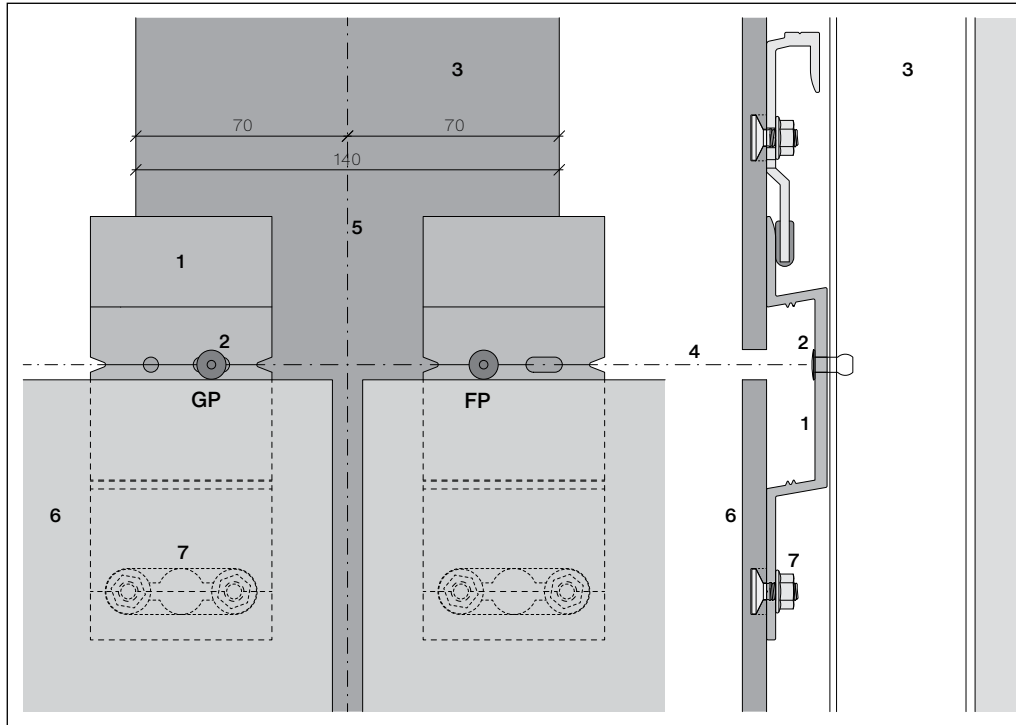

- 1 Omega cleat S8 Pro
- 2 Rivets S8 4.8×12-K9.0 mm
- 3 Support profile,
Alu T-profiles×45×2 mm,
black in the joint area, on site
- 4 Horizontal axis
- 5 Vertical axis
- 6 Largo panel 8 mm
- 7 Sigma 8 Pro system anchor

Left Omega cleat attachment: 1 Rivet 4.8×12-K9.0 mm into the slotted hole [SP=Sliding point]
 Right Omega cleat attachment: 1 Rivet 4.8×12-K9.0 mm into the round hole [FP=Fix point]

Outer corner

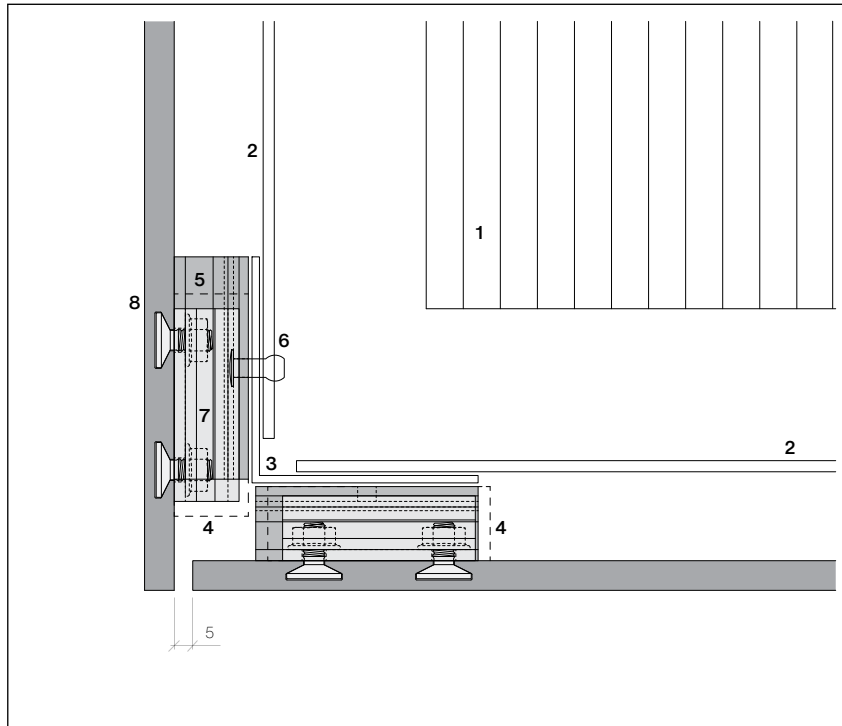

- 1 Thermal insulation
- 2 Corner profile holder with thermal separation
- 3 Alu angle 60 × 60 × 2 mm
- 4 Position Omega cleat S8 Pro, dash point line
- 5 U-clasp S8
- 6 Rivets S8 4.8 × 12-K9.0 mm
- 7 Hook-in cleat S8 Pro
- 8 Largo panel 8 mm

Mount U-cleat on the profile alignment with 2 rivets S8 4.8 × 12-K9.0 mm each.

Inner corner

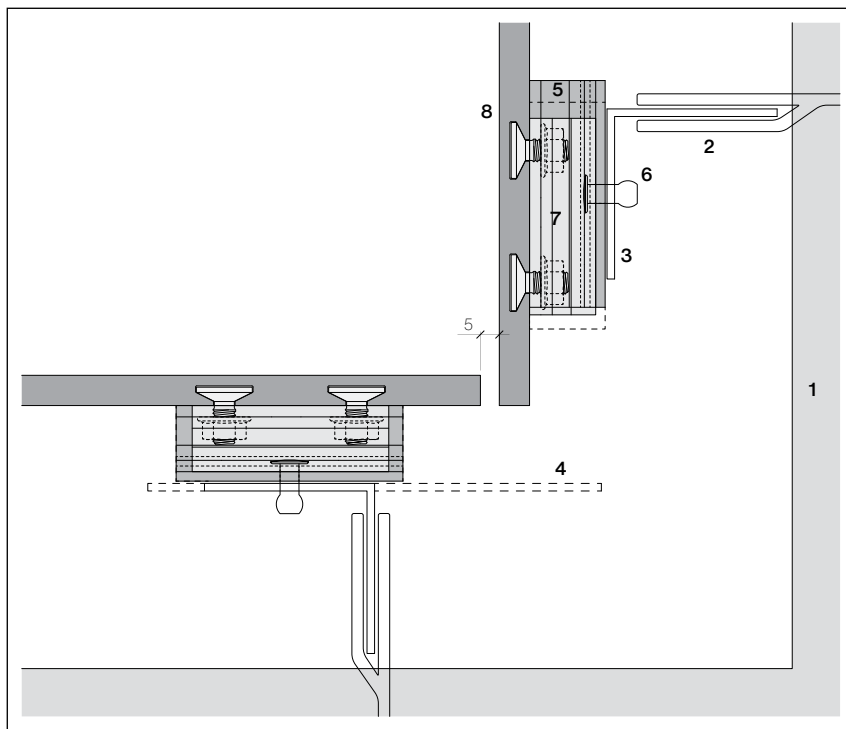

- 1 Thermal insulation
- 2 Consoles with thermal separation
- 3 Support profile,
Alu 45 × 45 × 2 mm
- 4 Optional T-profile
(vertical joint with backing),
black in the joint area
- 5 U-clip S8
- 6 Rivets S8 4.8 × 12-K9.0 mm
- 7 Hook-in cleat S8 Pro
- 8 Largo panel 8 mm

Mount U-clip on the profile alignment with 2 rivets S8 4.8 × 12-K9.0 mm each.

Window frame, horizontal section

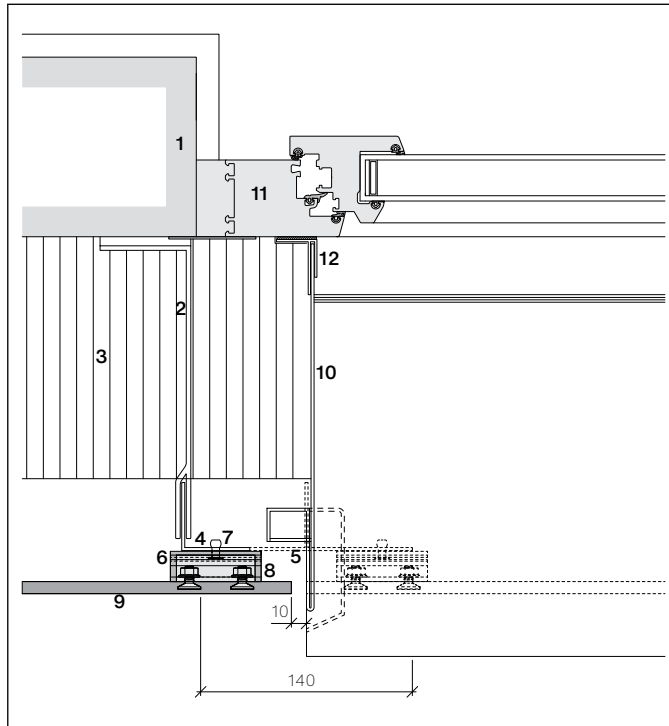

- 1 Substrate, supporting structure
- 2 Sub-construction
- 3 Thermal insulation
- 4 Support profile, Alu 45×45×2 mm
- 5 Support profile, Alu T-profiles×45×2 mm, black in the joint area

Window frame, vertical section

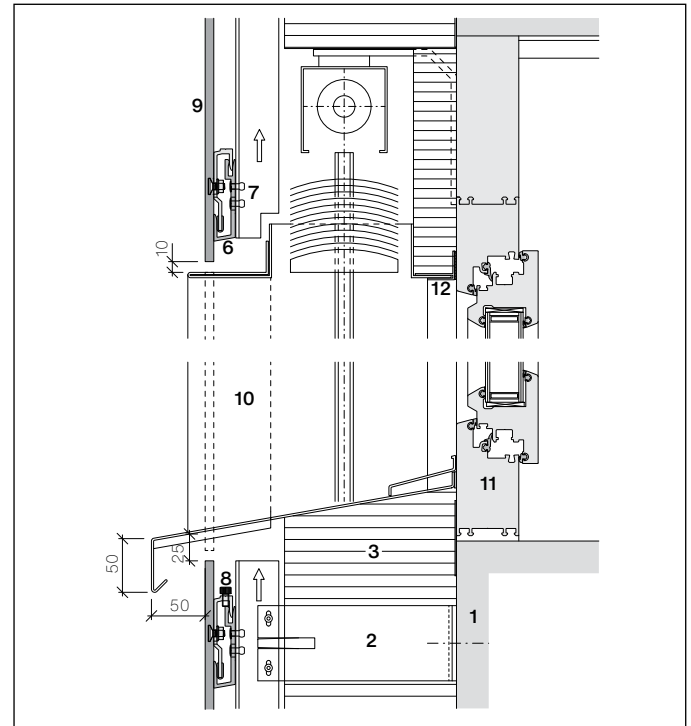

- 6 U-cleat S8
- 7 Rivets S8 4.8×12-K9.0 mm
- 8 Hook-in cleat S8 Pro (with adjustment)
- 9 Largo panel 8 mm
- 10 Frame
- 11 Window
- 12 F-profile with seal

Window jamb

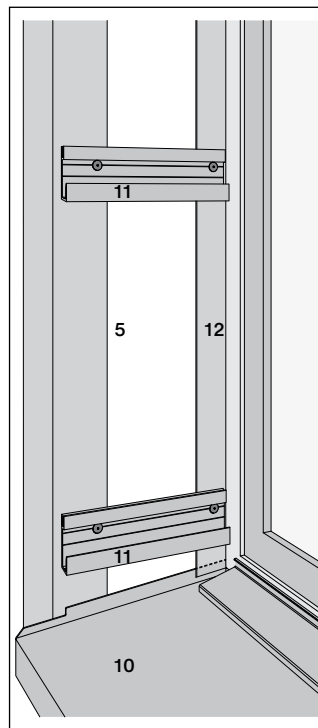
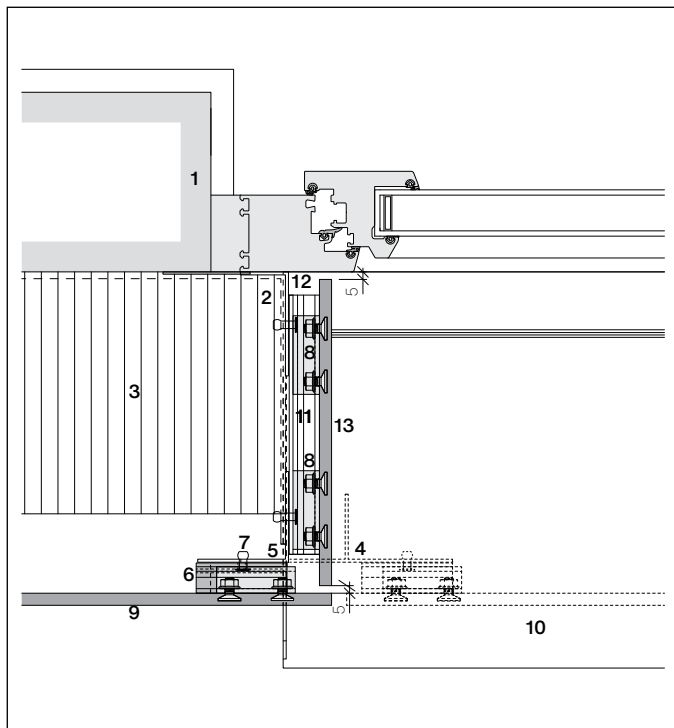

- 1 Substrate, supporting structure
- 2 Corner profile holder
- 3 Thermal insulation
- 4 Support Alu T-profile 140×45×2 mm
- 5 Alu angle 60×60×2 mm
- 6 U-clip S8
- 7 Rivets S8 4.8×12-K9.0 mm
- 8 Hook-in cleat S8 Pro
- 9 Largo panel 8 mm
- 10 Window sill
- 11 U-profile rod S8, black anodized, cut and pre-drill Ø 5 mm (rods 3 m each, standard product line)
- 12 Alu angle 60×20×2 mm, with seal
- 13 Largo window jamb panel

Window sill

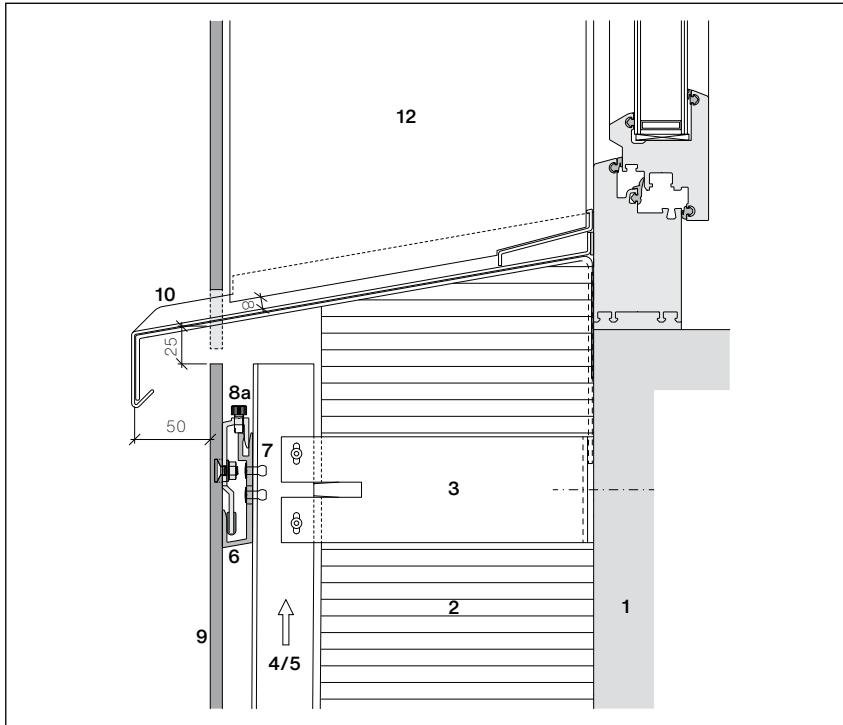

The 20 mm hook-in distance must be strictly observed.
The joint between the window jamb and the window sill is 8 mm.

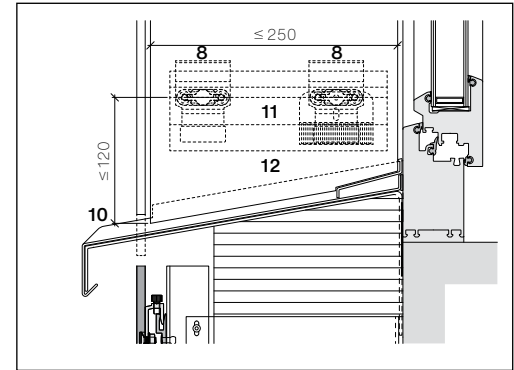

The maximum vertical distance of 100 mm may be increased to 120 mm at the window jamb.
For window jamb widths over 250 mm, the lower suspension points must be offset.

- 1 Substrate, supporting structure
- 2 Thermal insulation
- 3 Consoles with thermal separation
- 4 Vertical support profile - T-profile, black in the joint area
- 5 Support profile, Alu 45 × 45 × 2 mm
- 6 U-cleat S8
- 7 Rivets S8 4.8 × 12-K9.0 mm
- 8 Hook-in cleat S8 Pro (8a with adjustment)
- 9 Largo panel 8 mm
- 10 Window sill
- 11 U-profile rod S8, black anodized,
- 12 Largo window jamb panel

Lintel

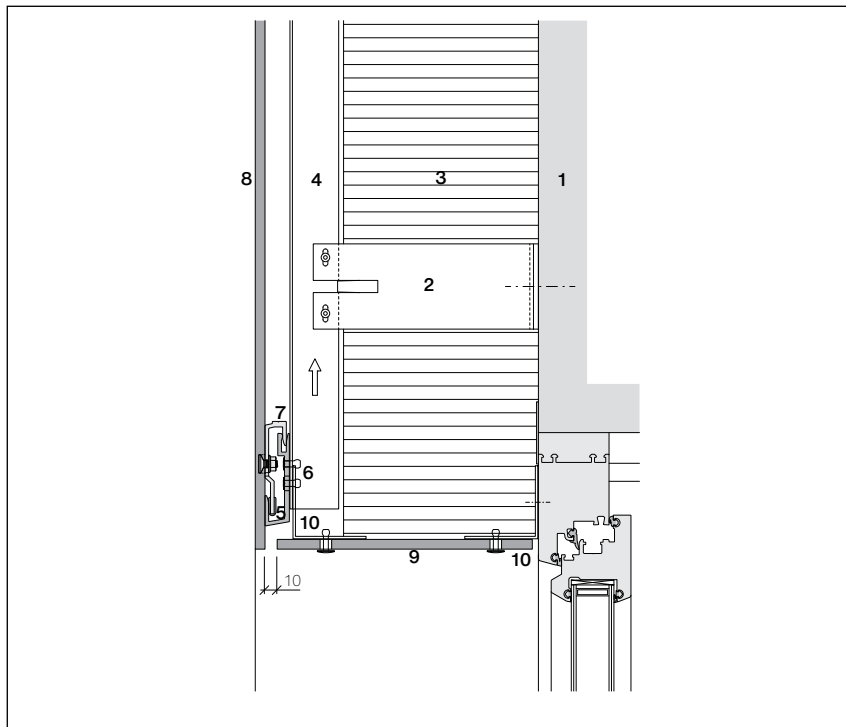

- 1 Substrate, supporting structure
- 2 Consoles with thermal separation
- 3 Thermal insulation
- 4 Vertical support profile
black in the joint area
- 5 U-cleat S8
- 6 Rivets S8 4.8 × 12-K9.0 mm
- 7 Hook-in cleat S8 Pro
- 8 Largo panel 8 mm
- 9 Largo header panel 8 mm
(anchor and sliding points)
- 10 Alu angle 60 × 60 × 2 mm

Sub-construction for lintel

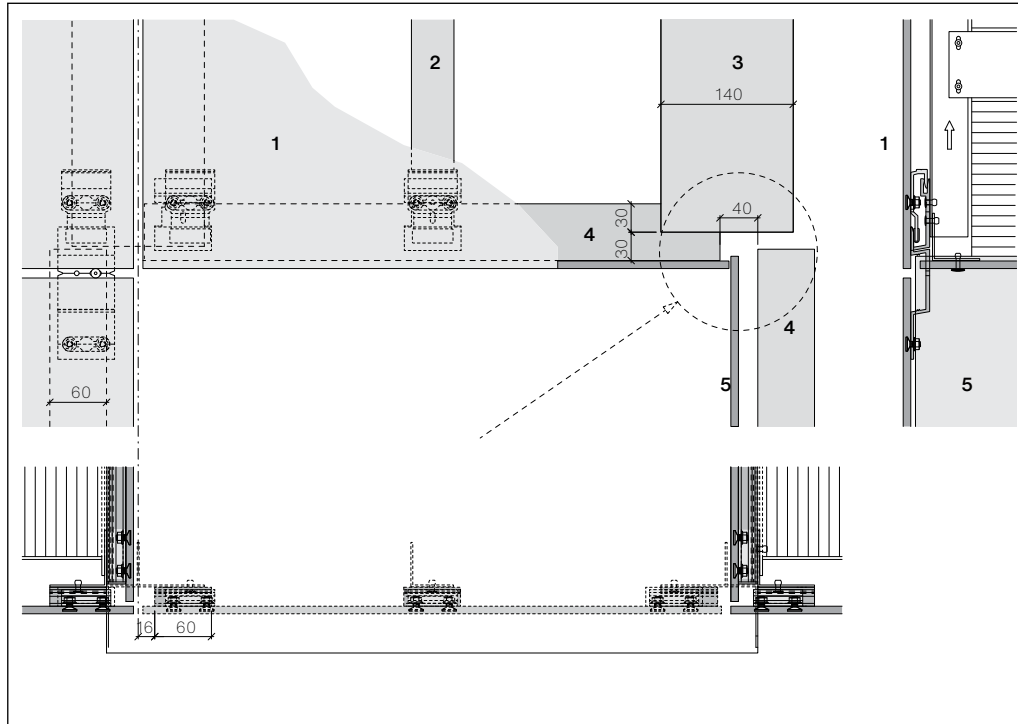

- 1 Largo panel 8 mm
- 2 Support profile, Alu 45 × 45 × 2 mm
- 3 Alu support T-profiles 140 × 45 × 2 mm,
- 4 Alu angle 60 × 60 × 2 mm
- 5 Largo window jamb panel 8 mm

In order to suspend the window jamb, the header sub-construction must have a distance of 40 mm from the window jamb sub-construction.

Lintel with blinds

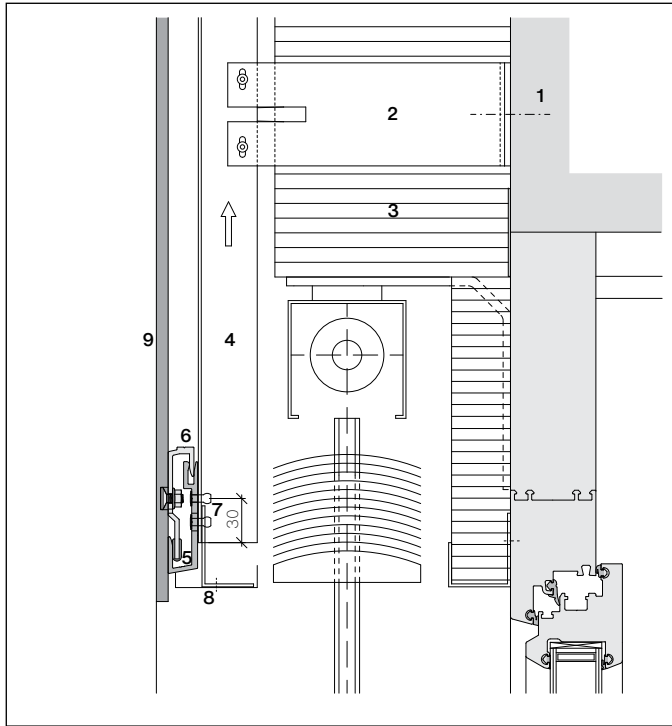

- 1 Substrate, supporting structure
- 2 Consoles with thermal separation
- 3 Thermal insulation
- 4 Vertical support profile,
black in the joint area
- 5 U-bleat S8
- 6 Hook-in cleat S8 Pro
- 7 Rivets S8 4.8×12-K9.0 mm
- 8 Mounting profile with bezel
- 9 Largo panel 8 mm

Version with U-cleats, mounted on profiles

Roof edge

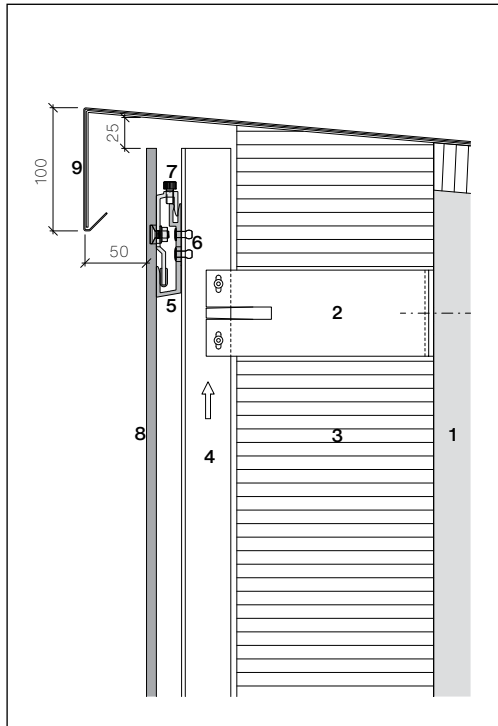

Roof edge termination

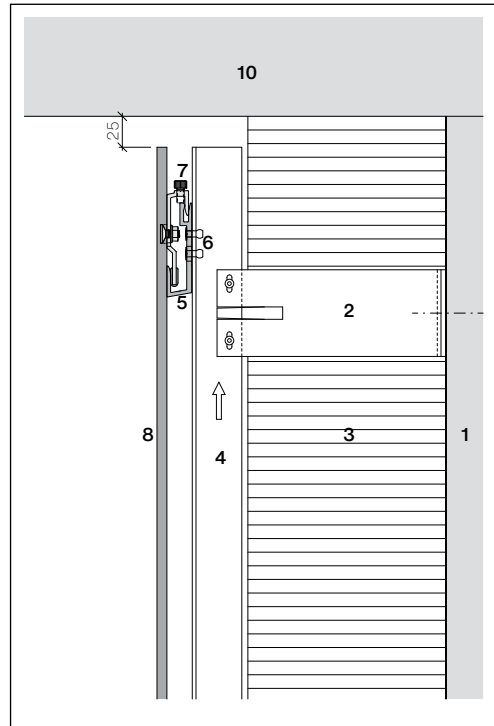

Connection at the soffit

- 1 Substrate, supporting structure
- 2 Console with thermal separation
- 3 Thermal insulation
- 4 Vertical support profile, black in the joint area
- 5 U-cleat S8
- 6 Rivets S8 4.8 x 12-K9.0 mm
- 7 Hook-in cleat S8 Pro with adjustment
- 8 Largo panel 8 mm
- 9 Roof edge cover
- 10 Soffit

The 20 mm hook-in distance must be strictly observed.

Base connection

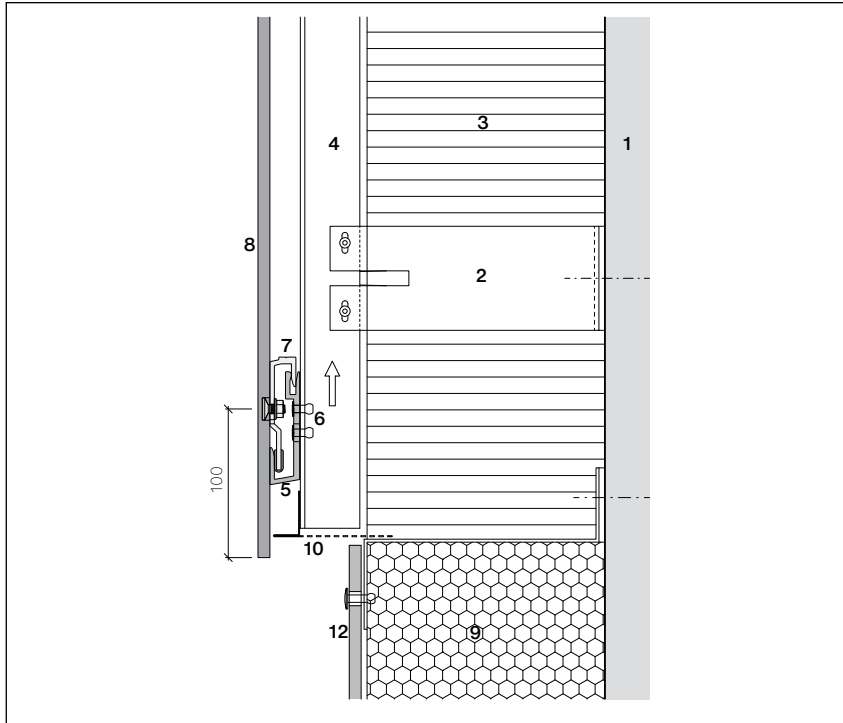

When using the partially perforated ventilation profile, the vertical edge distance must be 100 mm.

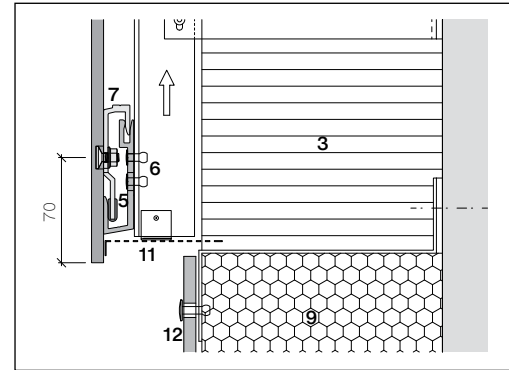

Design solution variant with ventilation profile, on site, with vertical margin distance of 70 mm (standard).

- 1 Substrate, supporting structure
- 2 Console with thermal separation
- 3 Thermal insulation
- 4 Vertical support profile, black in the joint area
- 5 U-clip S8
- 6 Rivets S8 4.8 × 12-K9.0 mm
- 7 Hook-in cleat S8 Pro
- 8 Largo panel 8 mm
- 9 Perimeter insulation
- 10 Ventilation profile S8
- 11 Ventilation profile, on site
- 12 Base panel
(construction panel Plus/Largo)

Workflow for retrofitting or replacing Sigma 8 Pro panels

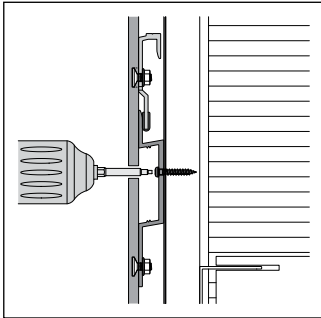

For wood sub-const.,
loosen screws

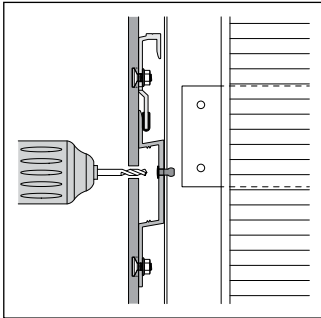

For metal sub-const., drill out
rivets

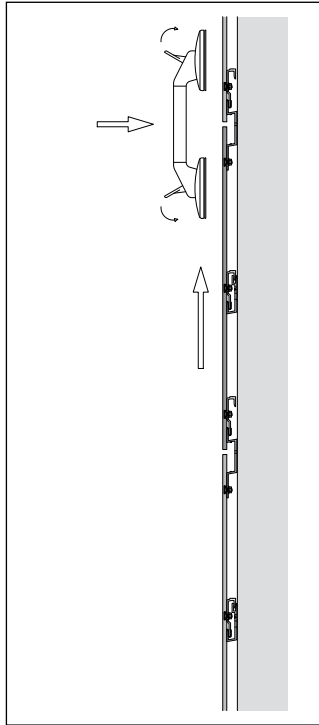

Lift the panel over the entire
joint height and secure it with
the suction cup lift.

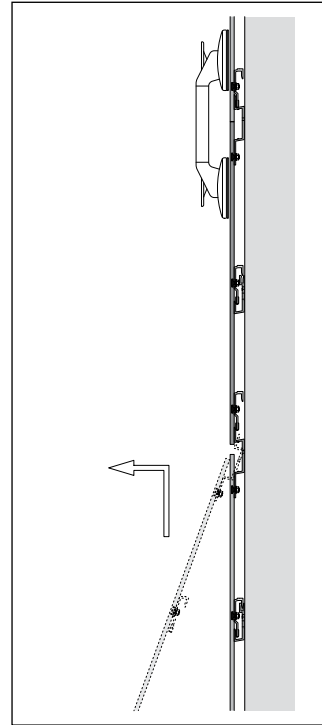

Lift and unhook the defective
panel.

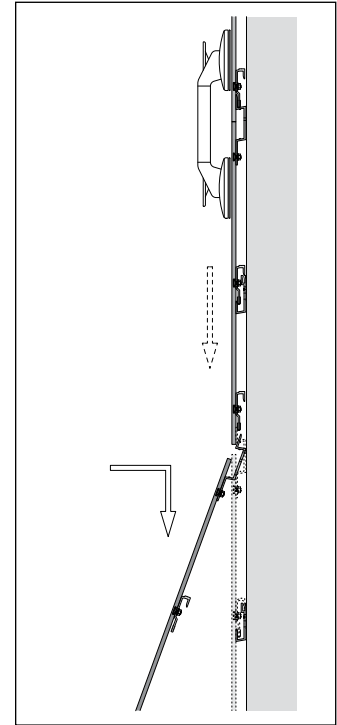

Attach new panel, secure and reset
top panel. For scaffolding anchors
the procedure is the same.

Setting up the work site

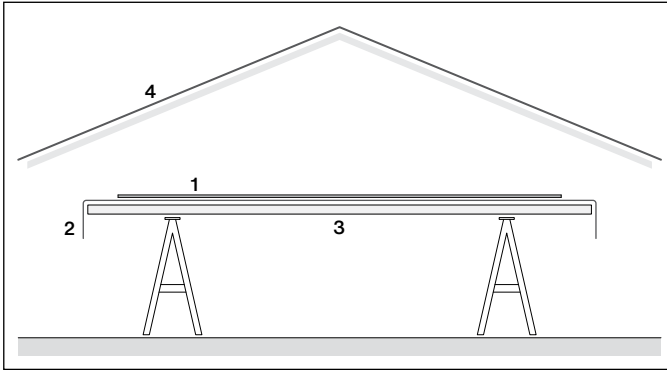

A protected workplace should be provided for the cleat assembly. To avoid damage to the visible side of the panel surface, the work table must be equipped with a protective layer.

- 1 Largo panel 8 mm
- 2 Protective layer
- 3 Work table
- 4 Protective roof

Interim construction-site storage

During transport and storage (intermediate storage, construction site), the panels must be protected from damage, sun, moisture and dirt.

The cover (at delivery from the factory) is meant for transport and is not protection against moisture.

Cover the stack of panels

Cover materials (tarpaulins) must be used in such a way that ventilation of the panel stacks is guaranteed.

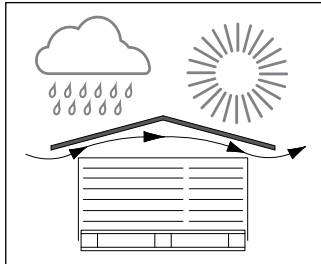

Protect stacks from moisture and direct sunlight under a roof or covered with a tarpaulin. The protective foil alone is not enough.

Stacking

- Always stack the panels horizontally on pallet base
- Each stack should not be more than 500 mm high.
- Use foam protection layer between the panels (as supplied by factory)
- 4 stacks on top of each other

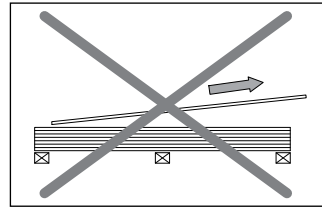

Do not pull panel across...

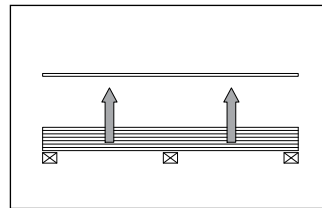

... but lift up vertically.

Use of accessories

The use and correct assembly of original accessories from Swisspearl guarantees flawless functionality.

Guidelines

The relevant accident prevention measures to avoid injuries and property damage must be strictly followed.

Risk of injury is present during transport and assembly

During transport, storage and assembly work, all measures must be taken to avoid the risk of injury, property damage, and consequential damage due to faulty assembly.

Appropriate work clothing, work gloves and safety footwear must be worn.

The panels that are bundled into pallets may only be moved if the panels are correctly secured with locking elements.

Risk of injury is present if panels are not secured.

To avoid injury and damage to property, the panels must always be installed in such a way that they cannot loosen and fall off.

The assembly guidelines of Swisspearl must be strictly observed. In some cases, additional precautions must be taken in accordance with the regulations specified in the assembly guidelines.

Working with fiber cement products

If fiber cement boards have to be worked on at the construction site, devices must be used that do not produce fine dust or that suction it off. Consult Swisspearl technical service if there are any questions or doubts.

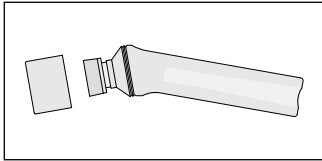
LUKO hand applicator

The Luko hand applicator is filled with a frost-resistant medium for saturating cutting edges and cutouts at the construction site. It is furnished as an accessory free of charge.

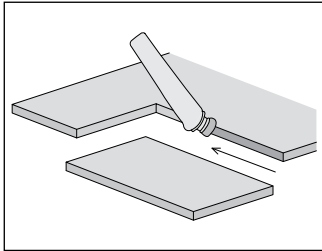

All cut edges must be sealed with impregnation liquid LUKO. Immediately wipe Luko off the face of the material.

Cut shapes, cutouts

For longer, straight cuts, a hand saw with diamond blade is suitable. It should be equipped with an industrial vacuum cleaner. Guide rails are available in different lengths for precise cuts. A jigsaw or saber saw with a carbide blade is suitable for smaller cutouts.

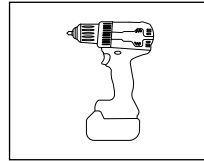

Cordless drill

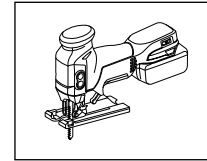

Jig saw

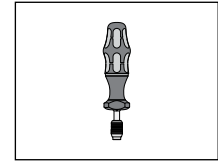

Torque wrench

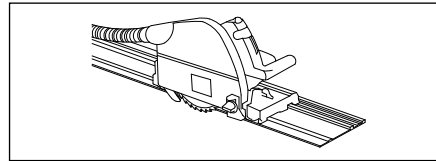

Dip-circular saw with guide

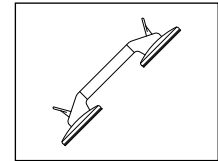

Vacuum handle with silicone cups.

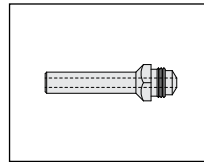

Mouthpiece S8 to Gesipa AccuBird®

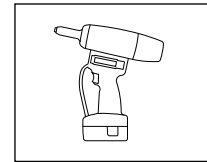

Gesipa riveting device AccuBird®

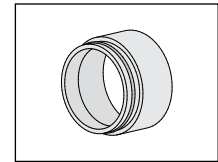

Receiving container extension for Gesipa AccuBird®

Cleaning

During the assembly of Largo facade panels, drilling, cutting and grinding dust as well as dirt from the scaffolding and the surrounding areas are released onto the facade. These dirt deposits consist of coarse, sand-like and fine-dust particles, which also contain lime compounds and are under the influence of moisture and carbon dioxide converted into water-insoluble calcium carbonate within a short time. If the contaminated facade is dry cleaned, the coarse and fine-dirt particles and the calcium carbonate can smear the facade surface, leaving a white veil and may even scratch the surface of the colored layer.

For that reason, we do not recommend dry cleaning of Swisspearl facade products.

Cleaning during assembly

Remove drilling and cutting dust immediately after processing.

• Dry dust

Removal is best done with a suction device or a dry, soft and clean cloth, microfiber cloth or similar.

• Wet dust

It leads to spots on the coating layer. Therefore, it must be removed immediately with plenty of water and a sponge. If necessary, a vinegar cleaner can also be used.

Final cleaning

Calcareous contamination

1. Spray the cleaning vinegar (9.5%) on contaminated areas using a garden sprayer. Make sure that as little as possible of the cleaning fluid gets onto the ground or into the groundwater (Attention: Cleaning vinegar must not come into contact with bare metal parts).

2. Allow it to sit for approximately 5-20 minutes, but do not allow it to dry!

3. Flush facade with cold water and a pressure washer. Working pressure: 40-80 bar. It is essential to test the setting on an inconspicuous place.

4. Heavily soiled areas: Repeat steps 1-3.

5. Dry the facade covering with a microfiber cloth

Not calcareous Dirt

Flush facade with cold water with a high-pressure washer. Working pressure 40-80 bar. It is essential to test the setting on an inconspicuous place.

Important!
Never clean in bright sunshine!

Cleaning Nobilis- + Carat-HR Information for cleaning

Information on graffiti on Carat HR can be found at swisspearl.com

Masking tape

When covering fiber cement panels for connection work, it should be noted that conventional standard masking tapes are usually not UV-resistant. They leave adhesive residues after a short time, which cannot be removed without damaging the panels.

We therefore recommend

- For temporarily use over 1-2 weeks, use the blue long-term masking tape [3M 2090](#)
- For longer use up to 6 months the Super masking tape, Gold [3M 244](#)



Swisspearl Group AG

Eternitstrasse 3
8867 Niederurnen
Switzerland
+41 55 617 11 60
info@swisspearl.com

swisspearl.com