

Approval body for construction products
and types of construction

Bautechnisches Prüfamt

An institution established by the Federal and
Laender Governments



European Technical Assessment

ETA-17/0536
of 12 July 2018

English translation prepared by DIBt - Original version in German language

General Part

Technical Assessment Body issuing the
European Technical Assessment:

Deutsches Institut für Bautechnik

Trade name of the construction product

Swisspearl-undercut anchor Keil for Swisspearl-façade
panels of Eternit (Swiss) SA

Product family
to which the construction product belongs

Fastener for the rear fixing of façade panels made of fibre
cement flat sheets according to EN 12467:2012+A1:2016

Manufacturer

Eternit (Schweiz) AG
Eternitstraße 3
8867 NIEDERURNEN
SCHWEIZ

Manufacturing plant

Plant 1

This European Technical Assessment
contains

16 pages including 3 annexes which form an integral part
of this assessment

This European Technical Assessment is
issued in accordance with Regulation (EU)
No 305/2011, on the basis of

EAD 330030-00-0601

The European Technical Assessment is issued by the Technical Assessment Body in its official language. Translations of this European Technical Assessment in other languages shall fully correspond to the original issued document and shall be identified as such.

Communication of this European Technical Assessment, including transmission by electronic means, shall be in full. However, partial reproduction may only be made with the written consent of the issuing Technical Assessment Body. Any partial reproduction shall be identified as such.

This European Technical Assessment may be withdrawn by the issuing Technical Assessment Body, in particular pursuant to information by the Commission in accordance with Article 25(3) of Regulation (EU) No 305/2011.

Specific Part

1 Technical description of the product

The Swisspearl Undercut Anchor KEIL for Swisspearl façade panels of Eternit (Swiss) AG is a fastener made of a crosswise slotted anchor sleeve with internal thread and a rectangular sheet metal at the top, a related screw and a shimer. The anchor sleeve, screw and shimer are made of stainless steel.

The fastener is put into an undercut drill hole, locked against rotation by setting to the fixing member (single agraffe, double agraffe, long-span agraffe or panel load-bearing profile) and placed form-fitted and anchored way-controlled by pulling the screw.

The product description is given in Annex A. The material values, dimensions and tolerances of the components of the fastener not indicated in the annexes shall correspond to the values laid down in the technical documentation¹.

2 Specification of the intended use in accordance with the applicable European Assessment Document

The performances given in Section 3 are only valid if the fastener is used in compliance with the specifications and conditions given in Annex B.

The verifications and assessment methods on which this European Technical Assessment is based lead to the assumption of a working life of the anchors of at least 50 years. The indications given on the working life cannot be interpreted as a guarantee given by the producer, but are to be regarded only as a means for choosing the right products in relation to the expected economically reasonable working life of the works.

3 Performance of the product and references to the methods used for its assessment

3.1 Mechanical resistance and stability (BWR 1)

Essential characteristic	Performance
Characteristic resistance for tension and shear loads	See Annex C 1
Anchor distances and dimensions of members	See Annex C 1
Durability	Corrosion Resistance Class (CRC) III according to EN 1993-1-4:2015

3.2 Safety in case of fire (BWR 2)

Essential characteristic	Performance
Reaction to fire	Class A1
Resistance to fire	No performance assessed

¹ The technical documentation comprises all information of the holder of this ETA necessary for the production, installation and maintenance of the fastener; these are in particular design drawings. The part to be treated confidentially is deposited with Deutsches Institut für Bautechnik and, as far as this is relevant to the tasks of the approved bodies involved in the procedure of attestation of conformity, shall be handed over to the approved body.

English translation prepared by DIBt

4 Assessment and verification of constancy of performance (AVCP) system applied, with reference to its legal base

In accordance with EAD No. 330030-00-0601 the applicable European legal act is: [97/161/EG].
The system to be applied is: 2+

5 Technical details necessary for the implementation of the AVCP system, as provided for in the applicable European Assessment Document

Technical details necessary for the implementation of the AVCP system are laid down in the control plan deposited with Deutsches Institut für Bautechnik.

Issued in Berlin on 12 July 2018 by Deutsches Institut für Bautechnik

BD Dipl.-Ing. Andreas Kummerow
Head of Department

beglaubigt:
Aksünger

Installed fastener

Fixing example agraffe with facade panel

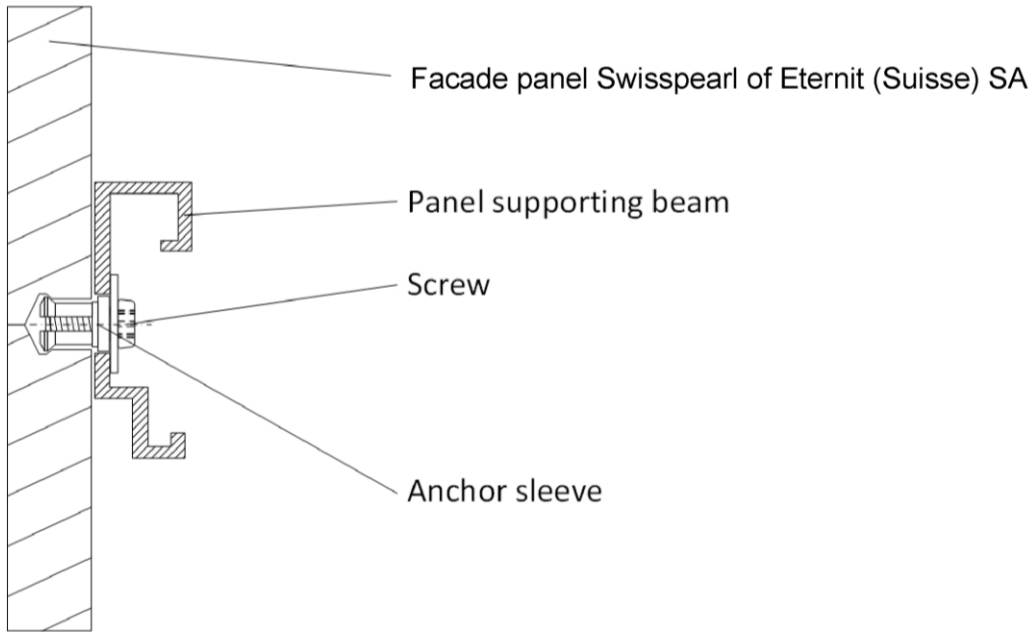

Fixing example panel supporting beam with facade panel

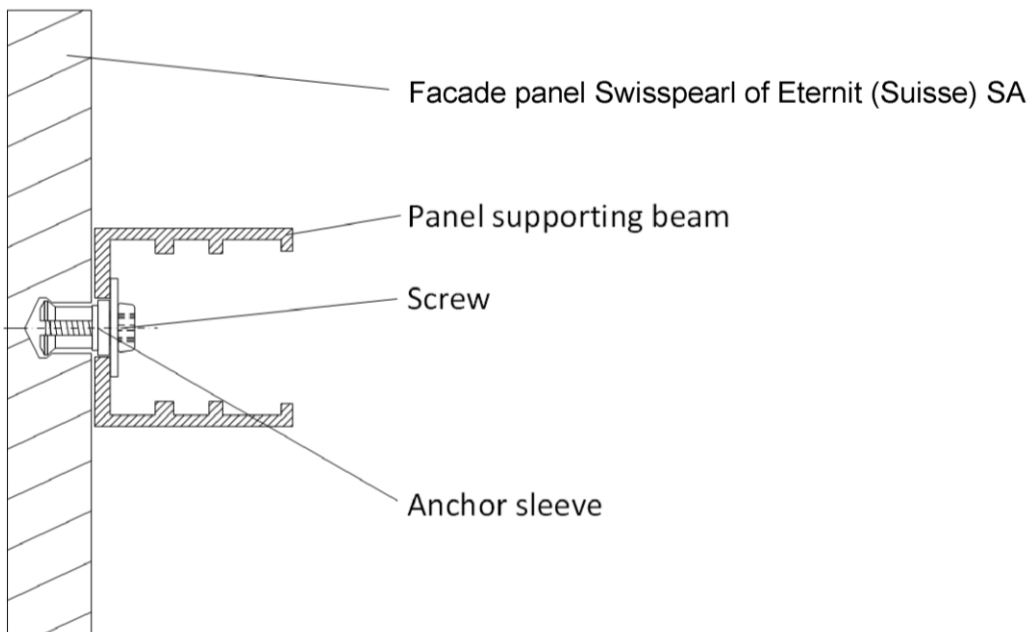

Swisspearl undercut anchor KEIL for façade panel Swisspearl of Eternit (Suisse) SA

Product description
Installed fasteners

Annex A 1

Example for a facade
construction with
agraffes

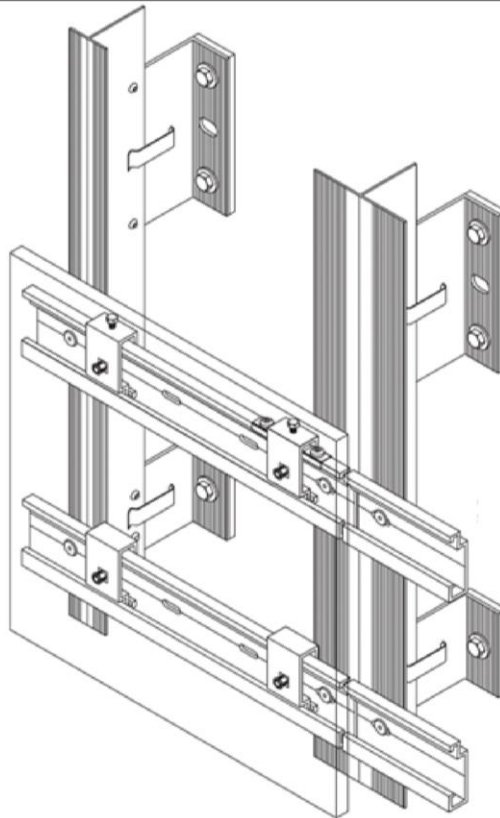

Example for a facade
construction with panel
supporting beam

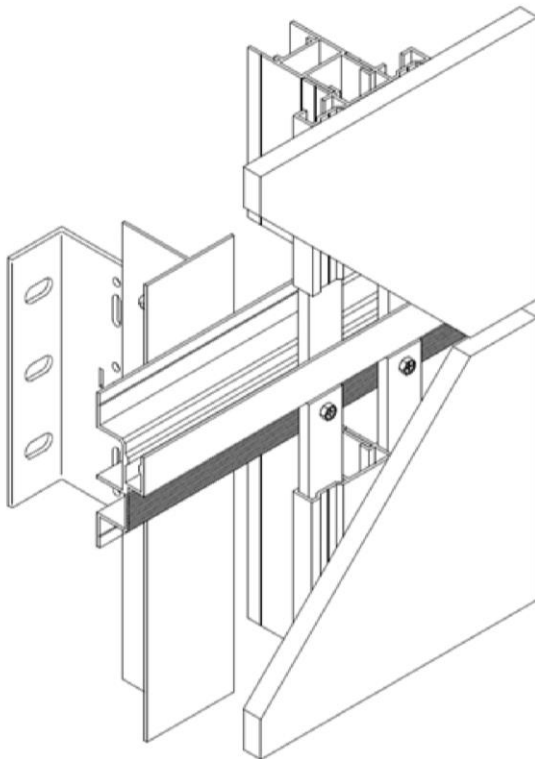

electronic copy of the eta by dibt: eta-17/0536

Swisspearl undercut anchor KEIL for façade panel Swisspearl of Eternit (Suisse) SA

Product description
Fixing examples

Annex A 2

Anchor sleeve and screw

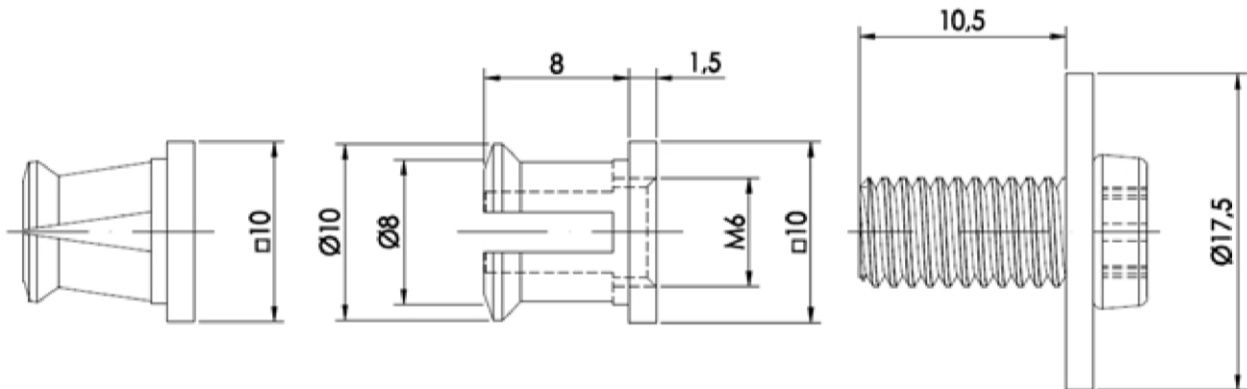

Supplied condition of the anchor sleeve

anchor sleeve

flat hat screw with rolled shim

Borehole geometry

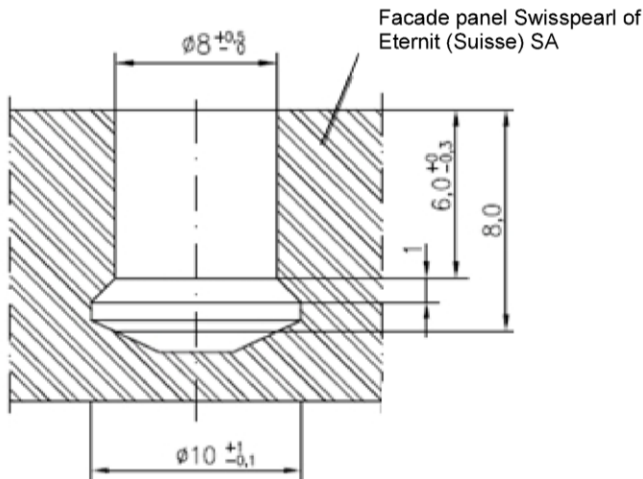

Table 1 Dimensions

embedment depth	$h_s =$	[mm]	8
panel thickness	$h_{nom} \geq$	[mm]	12
diameter of drill hole	$d_0 =$	[mm]	8
diameter of undercut	$d_1 =$	[mm]	10
installation torque moment	T_{inst}	[Nm]	$2,5 \leq T_{inst} \leq 4,0$

Table 2 Materials

anchor sleeve	Stainless steel in accordance with EN 10088:2014
Screw with shim	Stainless steel in accordance with EN 10088:2014

Swisspearl undercut anchor KEIL for façade panel Swisspearl of Eternit (Suisse) SA

Product description
Anchor sleeve and screw, borehole geometry

Annex A 3

Specifications of intended use

Anchorage subject to:

- Static and quasi-static loads.

Use conditions (Environmental conditions):

- According to EN 1993-1-4:2015 according to the Corrosion Resistance Class of the fastener (see ETA-text section 3.1)

Base materials:

- Swisspearl façade panels of Eternit (Suisse) SA according to EN 12467:2012
In regard to the properties, composition and other requirement of fibre-cement flat sheets, the flat sheet type "Swisspearl" comply with class 4, category A according EN 12467:2012.
For admissible deviation of the nominal dimensions apply level I according to EN 12467:2012. For admissible deviation of straightness of the edges and the admissible deviation of the rectangularity apply level I according to EN 12467:2012.
- The characteristic values of the façade plates correspond to Table B1.

Tabelle B1: characteristic values of the façade plates – geometrical und physical properties

Maximum panel size		$L_x \times L_y$ or $L_y \times L_x$	[mm]	3050 x 1250	
Nominal thickness of façade panel		$h_{nom} \geq$	[mm]	12	
Modulus of elastic		$E_{mean} =$	[N/mm ²]	15000	
Poisson ratio		$\nu =$	[-]	0,25	
density - dry		ρ	[g/cm ³]	1,80 - 1,95	
Grey cement based sheets	With acrylic coating	Bending stress (crossway direction) without climatic pre-stressing ²⁾	$\sigma_{5\%}^{1)} \geq$	[N/mm ²]	19,5
		Bending stress (crossway direction) after storage in water ³⁾	$\sigma_{5\%,WL}^{1)} \geq$	[N/mm ²]	14,3
	With 2k-PUR coating	Bending stress (crossway direction) without climatic pre-stressing ³⁾	$\sigma_{5\%}^{1)} \geq$	[N/mm ²]	19,6
		Bending stress (crossway direction) after storage in water ³⁾	$\sigma_{5\%,WL}^{1)} \geq$	[N/mm ²]	16,6
White cement based sheets	With acrylic coating	Bending stress (crossway direction) without climatic pre-stressing ²⁾	$\sigma_{5\%}^{1)} \geq$	[N/mm ²]	18,8
		Bending stress (crossway direction) after storage in water ³⁾	$\sigma_{5\%,WL}^{1)} \geq$	[N/mm ²]	14,5
	with 2k-PUR coating	Bending stress (crossway direction) without climatic pre-stressing ²⁾	$\sigma_{5\%}^{1)} \geq$	[N/mm ²]	17,2
		Bending stress (crossway direction) after storage in water ³⁾	$\sigma_{5\%,WL}^{1)} \geq$	[N/mm ²]	14,9

¹⁾ 5%-Quantil by a confidence level of 75 % and unknown standard deviation

²⁾ Dry storage, according to EN 12467:2012, table 10, line 2; the visible face of bending pressure zone.

³⁾ Storage in water, according to EN 12467:2012, table 10, line 2; the visible face of bending pressure zone.

Swisspearl undercut anchor KEIL for façade panel Swisspearl of Eternit (Suisse) SA

Intended use
Specifications

Annex B 1

Design:

General:

- Each façade panel is fixed with at least four anchors in a rectangular arrangement via single agraffes on the substructure (for small panels or small fitted pieces, differential or fill-in pieces the number and position of the anchors shall be chosen constructively).
- Edge distance and spacing shall be observed. For small fitted pieces, differential and fill-in pieces the edge distance and spacing shall be chosen.
- The substructure is constructed such that the façade panels are fixed technically strain-free via skids (loose bearings) and one fixed point (fixed bearing) - the fixed point may be placed at the panel edge or in the panel field.
- Two fixing points of the façade panel are designed such that they are able to carry the dead load of the façade panel.
- Constraint loads shall be into account for design, If constraint loads exists.
- When using agraffes on horizontal load-bearing profiles the fixing points of a façade panel situated horizontally at the same height are fastened in each case to the same load-bearing profile.
- The thickness of the fixing member (agraffe or panel load-bearing profile) shall be at least 2,0 mm and must not exceed 3,0 mm.
- At the agraffes or panel load-bearing profiles shall be arranged one square hole with 10.2 mm x 10.2 mm (fixed point). Agraffes with two anchors shall provide one rectangular hole with the dimension 10.2 mm x 14.2 mm (sliding point). At the panel load-bearing profile shall be arranged further holes with the dimension 10.2 mm x 20 mm to ensure a strain-free bearing of the façade panels at the panel load-bearing profile. Annex B 5 shows fixed points and loose points.
- Verifiable calculation notes and drawings shall be prepared taking account of the loads to be anchored, the nature and strength of the base materials and the dimensions of the anchorage members as well as of the relevant tolerances. The position of the anchor is indicated on the design drawings.

Swisspearl undercut anchor KEIL for façade panel Swisspearl of Eternit (Suisse) SA

Intended use
Specifications

Annex B 2

Verification ultimate limit state

Anchorage are designed under the responsibility of an engineer experienced in anchorages and facade construction.

$$\frac{N_{Ed}}{N_{Rd}} \leq 1$$

$$\frac{V_{Ed}}{V_{Rd}} \leq 1$$

$$\frac{N_{Ed}}{N_{Rd}} + \frac{V_{Ed}}{V_{Rd}} \leq 1,2$$

N_{Ed} : Design value of the tensile force

$$N_{Ed} = N_{EK,w} \cdot \gamma_F + N_{EK,V} \cdot \gamma_F$$

$N_{EK,w}$: characteristic value of the tensile force of wind load

γ_F : partial safety factor according to EN 1990:2010

$N_{EK,V}$: For flush fixed anchors and for installation of horizontal load-bearing profiles permanent loads due to torsion of the profile shall be considered in addition to actions from dead load and wind in direction of the anchor axes. The verification can be omitted, if there is no horizontal distance between anchor and vertical load-bearing profile ($N_{EK,V} = 0$).

$$N_{EK,V} = V_{EK} \cdot e/z$$

V_{EK} = characteristic value of the shear force due to dead load of the façade panel

e and z [mm] see picture

M shear centre

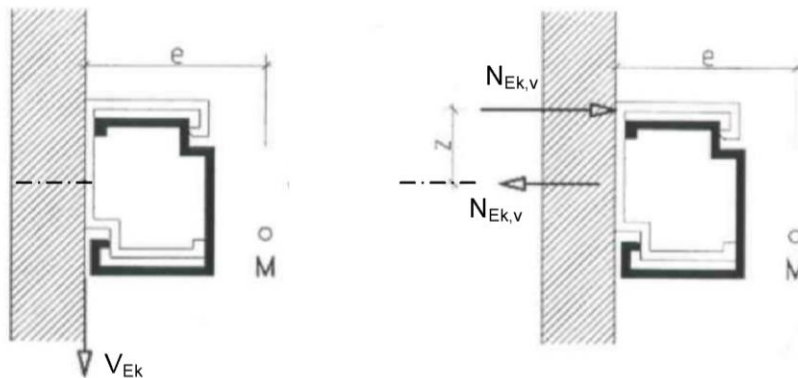

N_{Rd} : design value of the tensile load-bearing capacity

$$N_{Rd} = N_{Rk} / \gamma_M$$

N_{Rk} : characteristic value of the tensile load-bearing capacity according to Table C1

$\gamma_M = 1,8$; recommended partial safety factor, in absence of national regulations

V_{Ed} : design value of the shear force

$$V_{Ed} = V_{EK} \cdot \gamma_F$$

V_{EK} : characteristic value of the shear force

γ_F : partial safety factor according to EN 1990:2010

V_{Rd} : design value of the shear load-bearing capacity

$$V_{Rd} = V_{Rk} / \gamma_M$$

V_{Rk} : characteristic value of the shear load-bearing capacity according to Tabelle C1

$\gamma_M = 1,8$; recommended partial safety factor, in absence of national regulations.

Swisspearl undercut anchor KEIL for façade panel Swisspearl of Eternit (Suisse) SA

Intended use
Specifications

Annex B 3

Installation:

- The drillings are done at the factory or on site under workshop conditions; when making the drillings on site the execution is supervised by the responsible project supervisor or a skilled representative of the project supervisor.
- Making of the undercut drilling is done with the drill bit according to Annex B 7 and a special drilling device in accordance with the information deposited with Deutsches Institut für Bautechnik.
- In case of aborted hole: new drilling at a minimum distance away of twice the depth of the aborted hole.
- the geometry of the drill hole is checked on 1 % of all drillings. The following dimensions shall be checked and documented according to manufacturer's information and testing instructions by means of a measuring device according to Annex B 7:
 - Volume of the undercut drill hole.
 - Depth position of the undercut; the distance between the lower edge of the measuring device and the façade panel is between 0,0 and 0,3 mm (see Annex B 7).

If the tolerances given in Annex A 3, Table 1 are exceeded, the geometry of the drill hole shall be checked on 25% of the drillings performed. No further drill hole may exceed the tolerances otherwise all the drill holes shall be controlled. Drilling holes falling below or exceeding the tolerances shall be rejected.

Note: Checking the geometry of the drill hole on 1 % of all drillings means that on one of the 25 panels (this corresponds to 100 drillings in façade panels with four anchors) one drilling shall be checked. If the tolerances given in Annex A 3, Table 1 are exceeded the extent of the control shall be increase to 25 % of the drillings, i.e. one drilling each shall be checked on all the 25 panels.

- During transport and storage on site the façade panels are protected from damages; the façade panels are not be hung up jerkily (if need be lifters shall be used for hanging up the façade panels); façade panels and reveal panels respectively with incipient cracks are not be installed.
- The façade are installed by skilled specialists and the laying instructions of the manufacturer shall be paid attention to.
- The anchor is put into an undercut drill hole, locked against rotation by setting to the fixing member and placed form-fitted and anchored way-controlled by pulling the screw. Fixing the screw is achieved with a torque moment ($2,5 \text{ Nm} \leq T_{\text{inst}} \leq 4,0 \text{ Nm}$) using a calibrated torque.
- Installation of the anchor in rectangular holes (sliding points) needs additional spring washers between anchor sleeve and washer.
- The façade panels are arranged in a "reclined" or "upright" position.
- Overhead installation is allowed (e.g.: fastening cladding of ceilings)

Swisspearl undercut anchor KEIL for façade panel Swisspearl of Eternit (Suisse) SA

Intended use
Specifications

Annex B 4

Definition of edge distance and spacing
single fixing

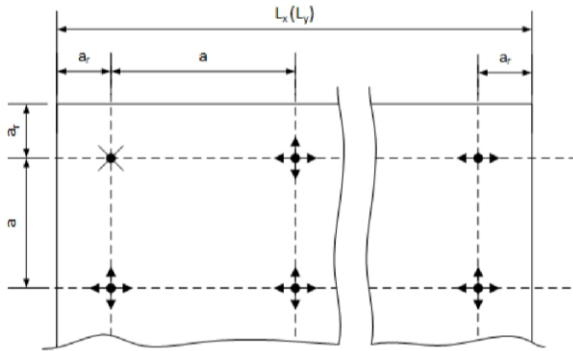

fixing with double agraffes

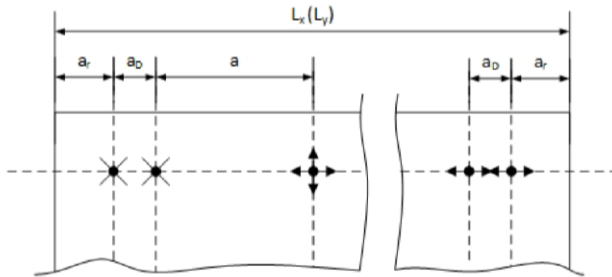

Legend

- a = spacing – distance between anchors
- a_D = spacing – distance between anchors of double agraffes
- a_r = edge distance – distance between anchor and panel edge
- L_x = length of the facade panel in horizontal direction
- L_y = length of the facade panel in vertical direction
- = fixed point (locating bearing) between facade panel and substructure
- = horizontal sliding point (floating bearing) between panel and substructure
- = horizontal and vertical sliding point between facade panel and substructure

Geometry of holes in the mounting part for fixed point and horizontal sliding point

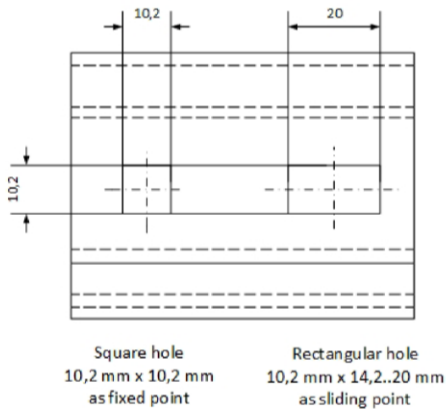

Swisspearl undercut anchor KEIL for façade panel Swisspearl of Eternit (Suisse) SA

Intended use
Definition of edge distance and spacing

Annex B 5

Driller geometry

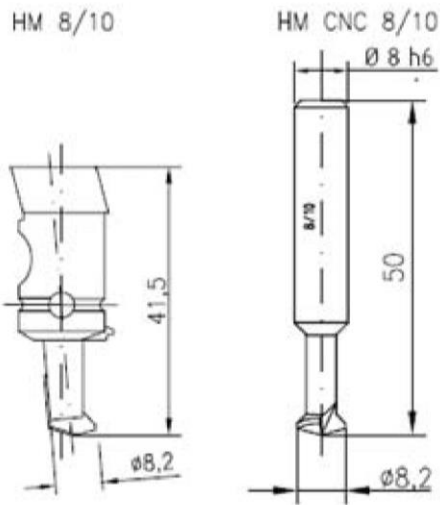

Measurement device

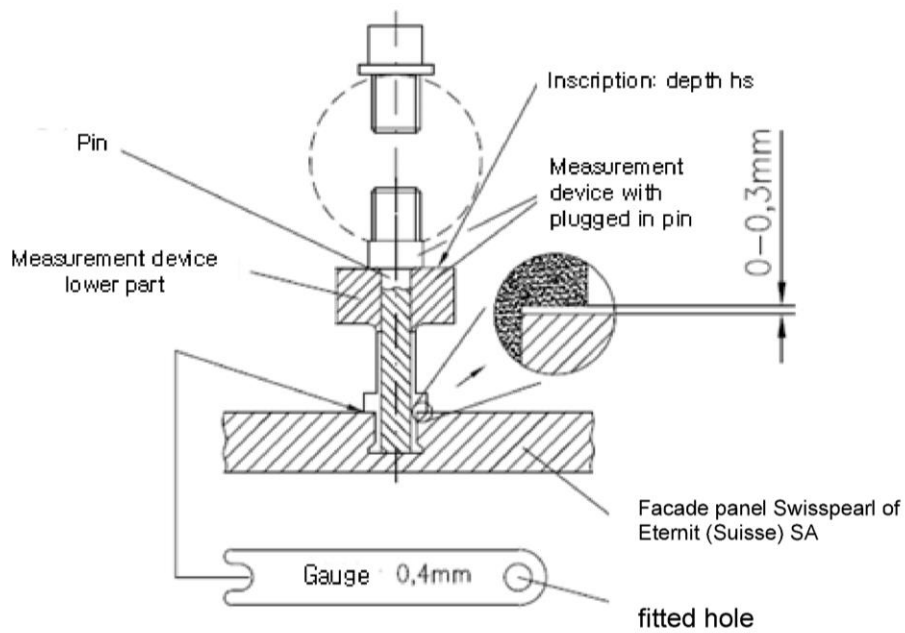

Swisspearl undercut anchor KEIL for façade panel Swisspearl of Eternit (Suisse) SA

Intended use
Driller geometry and measurement device

Annex B 6

Installation instruction

1. Generate of undercut hole

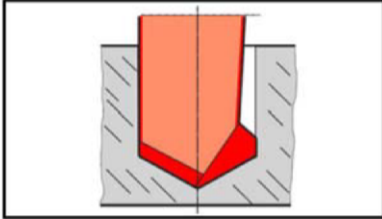

a) Drilling

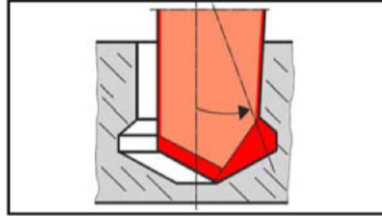

b) Undercutting

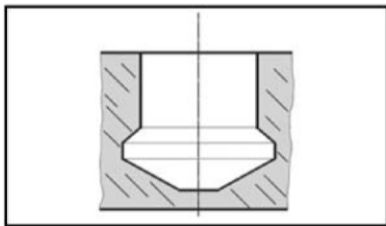

c) Undercut Hole

2. Checking the undercut hole

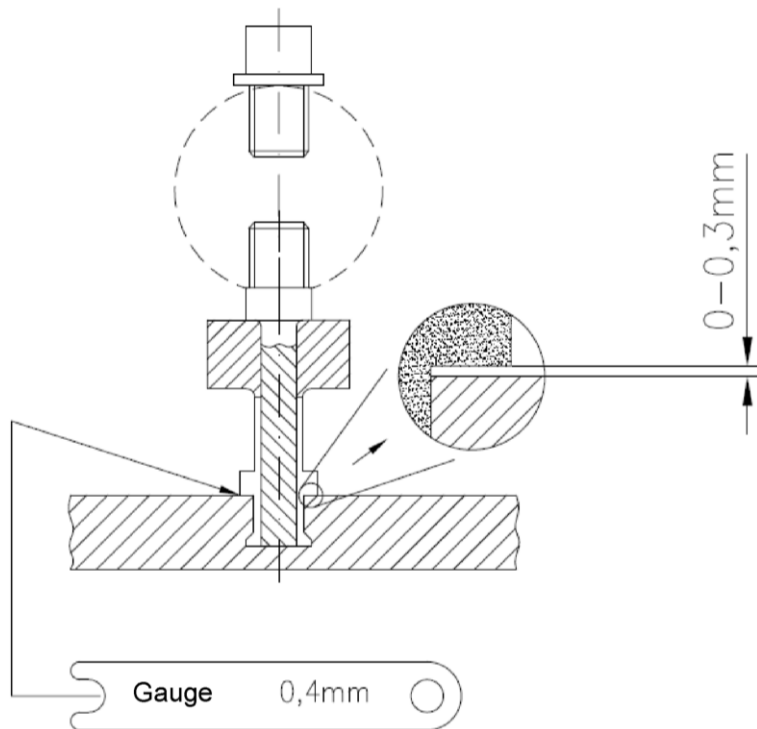

Swisspearl undercut anchor KEIL for façade panel Swisspearl of Eternit (Suisse) SA

Intended use
Installation instruction

Annex B 7

3. Installation (anchor sleeve and screw)

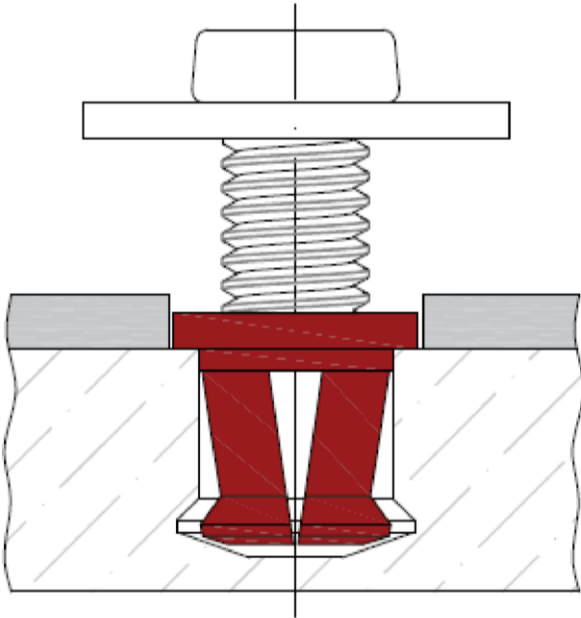

a) Form fit installation of anchor sleeve by tightening with screw

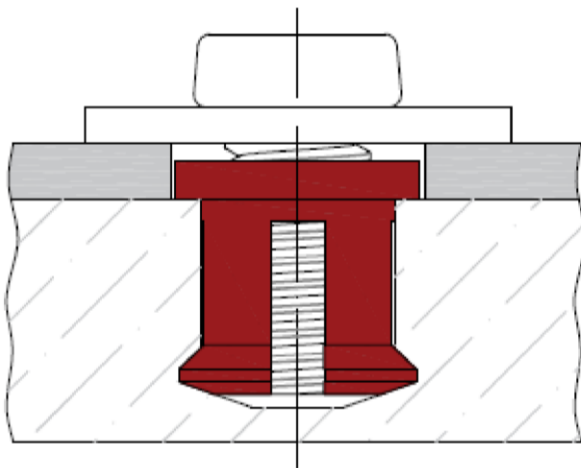

b) Installed undercut anchor

Swisspearl undercut anchor KEIL for façade panel Swisspearl of Eternit (Suisse) SA

Intended use
Installation instruction

Annex B 8

Characteristic values of the anchor in Swisspearl façade panel of Eternit (Suisse) SA according Table B 1

Table C1

Cement-base of the façade panel			white	grey
Embedment depth	$h_s =$	[mm]	8	
Characteristic resistance	tension load	$N_{RK} =$	1,03	1,27
	shear load	$V_{RK} =$	2,93	2,77
Edge distance	$a_r \geq$	[mm]	50	
Spacing	a	[mm]	$100 \leq a \leq 800$	
Spacing double agraffe	$a_D \geq$	[mm]	45	

Swisspearl undercut anchor KEIL for façade panel Swisspearl of Eternit (Suisse) SA

Performance

Characteristic values of the anchor in Swisspearl façade panel of Eternit (Suisse) SA

Annex C 1