

**SWISSPEARL**

# **DIM** Design & Installation Manual

## Swisspearl Multi Force





# Table of Contents

Swisspearl	4
Product Description	5-6
Wall Types and Dimensions	7-12
Abutments	13
Introduction	14
Sub-Construction	15
Surface treatment	16
Installation	17
Fastenings	18
Processing	19
Handling and Storage	20
Info	21

# Swisspearl

Swisspearl is one of the leading European manufacturers of multi-capability fibre cement building products. Our products and solutions add exciting new design opportunities for moulding attractive, durable settings for people's lives. But Swisspearl is more than mere products. We also help make all kinds of design and construction projects easier as well as more profitable, inspiring and effective. And for us, all construction also involves building relations with people, making your day better, and helping you make the day better for others.

## Remarks

This DIM (Design + Installation Manual) provides technical information regarding design and installation. Refer to area manager and local distributor for further information such as:

- Terms of delivery
- Pricing
- Products and colors
- Lead time, etc.

More general information available on [swisspearl.com](http://swisspearl.com).

## Swisspearl Sverige AB

Västberga allé 5, 10 tr  
Box 42013  
12612 Stockholm  
Telefon: +46 (0)8 506 608 00  
[info@se.swisspearl.com](mailto:info@se.swisspearl.com)

## Product Description

Swisspearl Multi Force is a fiber-cement board and is therefore strong and resistant to damp and mould. It also offers hard surface and high performance for fire protection and sound insulation.

## Quality

Swisspearl product specifications and classifications comply with EN 12467:2012 and 13501-1:2007+ A1:2009

## Applications

Thanks to the unique product properties of Swisspearl Multi Force, it can be used for various different applications. Walls, both shaft- and partition walls where fire protection, sound insulation and durability are needed, are natural places for Swisspearl Multi Force. It can also be used in

suspended ceilings, ceilings and balconies. Outdoor environment is not a problem as long as the product does not freeze when soaking wet. This means that you can install Swisspearl Multi Force to places like soffit, where a double layer of Swisspearl Multi Force 12 mm provides you with EI 30 resistance to fire.

## Appearance

Easily recognizable with its cement grey and glittering surface. The long edges of the standard boards are beveled (2-2mm 45°) and have predrilled holes (not penetrating the board).

## Fire Protection

Today safety in buildings is as important as ever. To answer the increasing requirements in fire protection, Swisspearl continuously develops and tests solutions for improved fire protection performance. Swisspearl Multi Force answers the increasing fire protection needs in especially wall and ceiling applications.

Reaction to fire according to EN 13501-1:2007+A1:2009 for Swisspearl Multi Force is the best possible non-combustible class A1. Large variety of structures for partition-, shaft- and exterior walls as well as ceilings and balconies have been tested according to EN 1364 and EN 1365 parts 1 and 2. The list of structures and classifications can be found from pages 5-10. In addition, one layer of Swisspearl Multi Force 9 mm gives K210 and K110 covering performance according to EN 13501-2:2007+A1:2009.

## Product warranty

Warranty conditions are available on request from your local Swisspearl office or dealer.

## Disclaimer

The information and recommendations contained in this Design & Installation Manual ("DIM") are offered as a service to architects, constructors, installer and other persons involved with our products and are not intended to relieve them from their own responsibility. The information and recommendations provided herein are believed by Swisspearl Group to be accurate at the time of preparation of this DIM, or obtained from sources believed to be generally reliable. Swisspearl Group makes no warranty concerning the accuracy of the content of this DIM and shall not be liable for claims relating to any use regardless of whether it is claimed that the information or recommendations are inaccurate, incomplete, or otherwise misleading. The information and recommendations herein are intended to be used with the judgment and experience of professional personnel competent to evaluate the significance and limitations of the material contained. Swisspearl Group expressly disclaims any guarantees or warranties, expressed or implied, for anything described or illustrated herein and assumes no responsibility or liability for damages of any kind, including – without limitation – bodily harm, injury or damage to property inferred from this DIM or the use of the materials described herein.

# Product Description

## Swisspearl Multi Force

### Sound Insulation

The combination of weight and stiffness means that Swisspearl Multi Force has high sounds insulation performance. General details related to sound insulation:

- E-modulus: 7 GPa
- Density: 1150 kg/m<sup>3</sup>
- Airborne sound insulation:
- 9 mm: 28 dB
- 12 mm: 31 dB

More details about the sound insulation can be found from pages 7 to 14 Sound Insulation

### Sound Insulation

**Strength and Impact Resistance**  
 Swisspearl Multi Force is a strong board for harsh environments. The number of boards and frame c-c spacing can be combined for various requirements. The diagram shows how to build the wall for various different requirements.

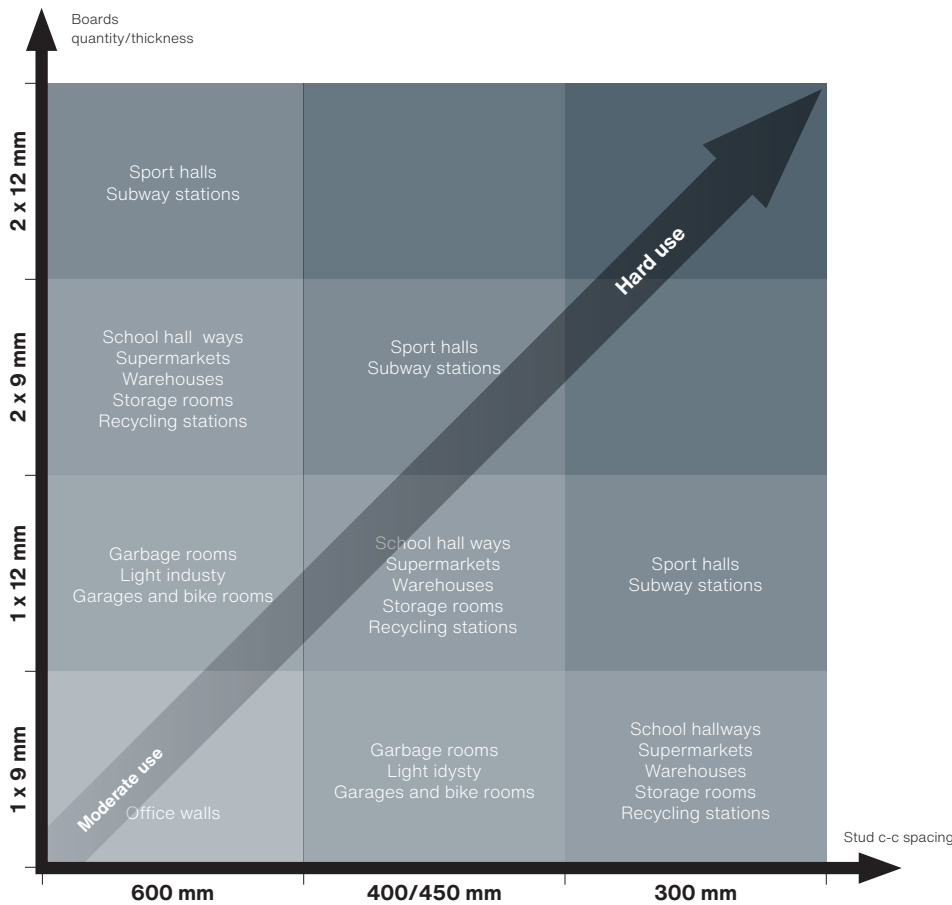

# Product Description

## Swisspearl Multi Force

### Water Resistant

Virtually unaffected by being wet. Can tolerate pressure washing, absorb and release damp in an infinite number of cycles without losing density or strength.

### Resistant to Mould and Rot

The high pH value (11) prevents the growth of mould and other micro-organisms. The boards cannot rot, rust or degrade in any way in damp environments. Technical Research Institute of Sweden (SP) found it almost impossible to provoke mould growth on Swisspearl Multi Force and therefore uses the product as reference for comparison of other materials.

### Resists Biological Attack

Unaffected by micro-organisms, alkaline or organic solvents. Can however be affected by acids, such as sulphuric and nitric acid. Pests such as mice and insects cannot touch Swisspearl Multi Force.

### Heat Resistant

Tolerates constant heat up to + 150 °C.

### Tolerates Cleaning

An untreated Swisspearl Multi Force tolerates cleaning with light high pressure washing and using mechanical aids. Another method for cleaning is to use a detergent solution followed by plentiful rinsing.

If heavy soiling and high exposure to chemicals, oil etc., we recommend surface treatment with a silane / siloxane sealer or a concrete impregnator / sealer.

### Edges

Standard Swisspearl Multi Force has beveled edges (2-2mm 45°). The boards are installed with butt joints. The beveled profile makes it easy to obtain a decorative effect. For a specific order the long edges can also be left square, or for the 12 mm thick board, the edges can be chamfered approx. 50 mm width and 1-2 mm depth.

### Standard



V-beveled edge 9 mm and 12 mm

### Make to order



Chamfered edge 12 mm



Square edge 9 mm and 12 mm

### Health and Environment

Swisspearl Multi Force consists of cement, limestone, mica and cellulose fibers. None of the contents are hazardous to health, including any dust created by cutting the boards. In emission tests by VTT in Finland, Swisspearl Multi force reached the best possible M1 classification. Environmental product declaration (EPD) for Swisspearl Multi Force can be found from [swisspearl.com](http://swisspearl.com)



# Wall Types and Dimensions

## Steel Frame

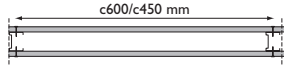
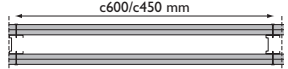
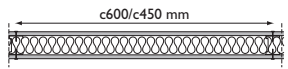
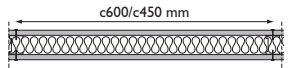
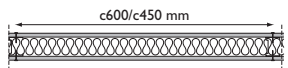
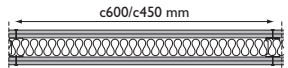
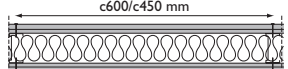
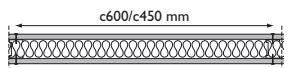
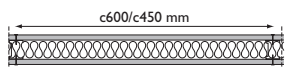
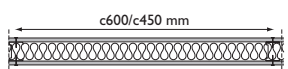
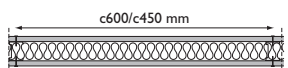
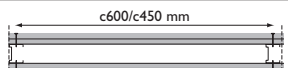
Fire Protection	Sound Insulation Rw [dB]	Max. Wall Height [mm]		Thickness [mm]	Wall Structure	Structure Code	Dimensions					
		c/c 450	c/c 600									
EI 30	30	3000	69	E 45/45 12-12 M0	S1a							
			94	E 70/70 12-12 M0	S1b							
			119	E 95/95 12-12 M0	S1c							
	35	3000	81	E 45/45 9+9-9+9 M0	S2a							
							35	3000	63	E 45/45 9-9 M45	S3a	
	35	3000	69	E 45/45 12-12 M45	S4a							
		4000	94	E 70/70 12-12 M70	S4b							
	40	3000	88	E 70/70 9-9 M70	S5a							
							40	3000	81	E 45/45 9+9-9+9 M45	S6a	
	44	4000	112	E 70/70 9+12-12+9 M70	S8a							
							44	4000	119	E 95/95 12-12 M95	S9a	
	40	4000	94	E 70/70 12-12 S70	S12a							
							40	4000	113	E 95/95 9-9 S95	S13a	
	40	4000	119	E 95/95 12-12 S95	S15a							
							EI 60	35	3000	93	E 45/45 12+12-12+12 M0	S10a
40	4000	118	E 70/70 12+12-12+12 M0	S14a								
						44						

# Wall Types and Dimensions

## Steel Frame

Fire Protection	Sound Insulation Rw [dB]	Max. Wall Height [mm]		Thickness [mm]	Wall Structure	Structure Code	Dimensions
		c/c 450	c/c 600				
	40	3000		81	E 70/70 9+9-9+9 S70	S17a	
	44	4000		106	E 45/45 9+9-9+9 M0	S18a	
EI 90	48	4000		131	E 95/95 9+9-9+9 S95	S19a	
	48	4000		131	D 70/95 9+9-9+9 S95	S20a	

### Explanations (walls):

E 45/45 12-12 M0: Single post; 45 mm post/45 mm rail; 12 mm Multi Force – 12 mm Swisspearl Multi Force; Mineral wool 0 mm; No. S1a E 45/45 9+9-9+9 S45: Single posts; 45 mm post/45 mm rail; 9+9 mm Swisspearl Multi Force – 9+9 mm Multi Force; rock wool 45 mm; No. S17a Swisspearl Multi Force D 70/95 9+9-9+9 M95: Split-level posts; c/c between posts 300/225 mm; 70 mm post/95 mm rail; 9+9 mm Swisspearl Multi Force – 9+9 mm Swisspearl Multi Force; Mineral wool 95 mm; No. S20a DD 70/70 9+9-9+9 S140: Double posts; c/c between posts 300/225 mm; 70 mm posts/70 mm rail; 9+9 mm Multi Force – 9+9 mm Swisspearl Multi Force; Rock wool 140 mm; No. S24a.

### Explanations (other):

Steel profiles: Hot-galvanized, cold-rolled sheets according to DS/EN 10327:2004

Steel rails: 0.56x30/b/30 mm, Z 275; b = rail width (45, 70 or 95 mm)

Steel posts: 0.56x5/40/h/43/5 mm, Z 275; h = profile height (45, 70 or 95 mm)

M: Mineral wool – glass wool or rock wool

### NOTE!

For EI 60 and up applies that rock wool must have a minimum density of 28kg/m<sup>3</sup>

S7a: 8 SP means 8 mm wet room board

S24a: 10 mm minimum distance between rails

# Wall Types and Dimensions

## Wooden Frame

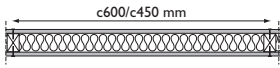
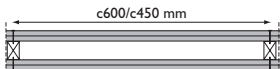
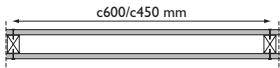
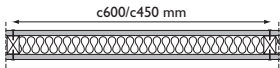
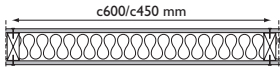
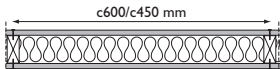
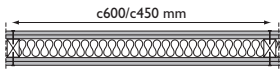
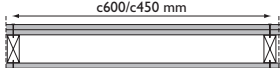
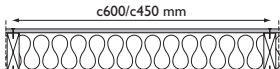
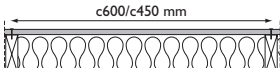
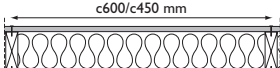
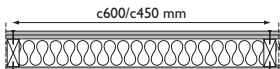
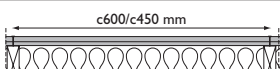
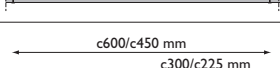
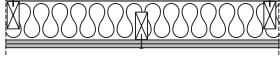
Fire Protection	Sound Insulation Rw [dB]	Max. Wall Height [mm]		Thickness [mm]	Wall Structure	Structure Code	Dimensions
		c/c 450	c/c 600				
EI 30	30	3000		63	E 45/45x45 9-9 M45	W1a	
	30	3000		81	E 45/45 9+9-9+9 M0	W2a	
	30	3000		69	E 45/45 12-12 M0	W3a	
	30	4000		94	E 70/70 12-12 M0	W3b	
	35	4000		119	E 95/95 12-12 M0	W3c	
	35	3000		69	E 45/45 12-12 M45	W4a	
	35	4000		88	E 70/70 9-9 M70	W6a	
	35	4000		94	E 70/70 12-12 S70	W16a	
	35	3000		81	E 45/45 9+9-9+9 M45	W7a	
	35	4000		106 131	E 70/70 9+9-9+9 M0 E 95/95 9+9-9+9 M0	W8a W8b	
	35	4000		113	E 95/95 9-9 S95	W17a	
	35	4000		119	E 95/95 12-12 S95	W19a	
	35	4000		119	E 95/95 12-12 M95	W9a	
	40	4000		106 131	E 70/70 9+9-9+9 M70 E 95/95 9+9-9+9 M95	W10a W10b	
	44	4000		137	E 95/95 9+12-12+9 M95	W11a	
	48	4000		131	D 70/95 9+9-9+9 M95	W12a	
	55	4000		176	DD 70/70 9+9-9+9 M2x70	W13a	

# Wall Types and Dimensions

## Wooden Frame

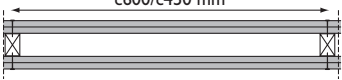
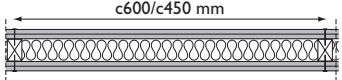
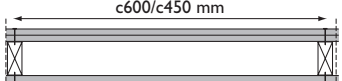
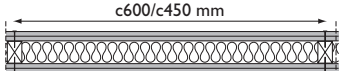
Fire Protection	Sound Insulation R <sub>w</sub> [dB]	Max. Wall Height [mm]		Thickness [mm]	Wall Structure	Structure Code	Dimensions
		c/c 450	c/c 600				
EI 60	35	3000		93	E 45/45 12+12-12+12 M0	W14a	
	35	3000		81	E 45/45 9+9-9+9 S45	W15a	
EI 60	35	4000		118	E 70/70 12+12-12+12 M0	W18a	
	40			143	E 95/95 12+12-12+12 M0	W20a	
EI 90	40	4000		106	E 70/70 9+9-9+9 S70	W21a	
				131	E 95/95 9+9-9+9 S95	W21b	

### Explanations (walls):

E 45/45 9-9 M45: Single posts; 45 mm post/45 mm rail; 9 mm Multi Force - 9 mm Multi Force; Mineral wool 45 mm; No. W1a

E 45/45 9+9-9+9 S45: Single posts; 45 mm post/45 mm rail; 9+9 mm Multi Force - 9+9 mm Multi Force; rock wool 45 mm; No. W15a D

70/95 9+9-9+9 S95: Split-level posts; c/c between posts 300/225 mm; 70 mm post/95 mm rail; 9+9 mm Multi Force - 9+9 mm Multi Force; Rock wool 95 mm; No. W23a DD 70/70 9+9-9+9 S140: Double posts; c/c between posts 300/225 mm;

70 mm posts/70 mm rail; 9+9 mm Multi Force - 9+9 mm Multi Force; Rock wool 140 mm; No. W24a

### Explanations (other):

Wooden rails: 45xb mm; b = rail width (45, 70 or 95 mm)

Wooden posts: 45xh mm; h = post height (45, 70 or 95 mm)

M: Mineral wool - glass wool or rock wool

### NOTE!



For EI 60 and up applies that rock wool must have a minimum density of 28kg/m<sup>3</sup> W24a: 10 mm minimum distance between rails

# Wall Types and Dimensions

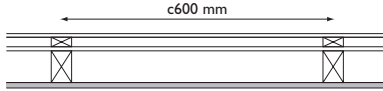
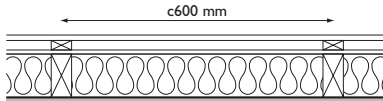
## Exterior Wall

Construction	Fire Proof Rating	Sound Insulation Rw	Structure of the Construction	Dimensions
Exterior wall, Y1	EI 30	35	Swisspearl facade board EPDM strips 21x45 mm stud 4.5 mm Swisspearl Windstopper Extreme 45x70 mm frame/stud c/c 600 12 mm Swisspearl Multi Force	
Exterior wall, Y2	EI 60	40	Swisspearl façade board EPDM strips 28x45 mm stud 4.5 mm or 9 mm Swisspearl Windstopper Extreme 45x95 mm frame/stud c/c 600 mm 95 mm rock wool 30 kg/m³ 12 mm Swisspearl Multi Force	

## Shaft Wall

Fire Protection	Sound Insulation Rw	Max. Wall Height	Thickness	Wall Structure	No.
EI 15	28	3000	12	1x12 mm Swisspearl Multi Force, Steelpost R70 max 600 mm c/c	SV 1a 
EI 30 / E 90	30	3000	24	2x12 mm Swisspearl Multi Force, Steelpost R70 max 600 mm c/c	SV 1b 

### Explanations (walls):

Wood profiles: Must comply with the regulations drawn up by The Danish Society of Engineers, IDA Steel profiles: Hot-galvanized, cold-rolled sheets according to DS/EN 10327:2004

## Roof eaves

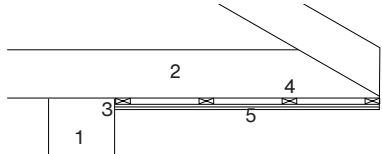
Fire Protection	Thickness	Roof eaves structure	No.
EI 30	24	<ol style="list-style-type: none"> <li>External wall EI30 - EI60</li> <li>Roof truss max c1200</li> <li>Fire seal</li> <li>28x70mm batten, gauge max c400</li> <li>2x12mm Multi Force</li> </ol>	ER 1a 

# Wall Types and Dimensions

## Suspended Ceilings

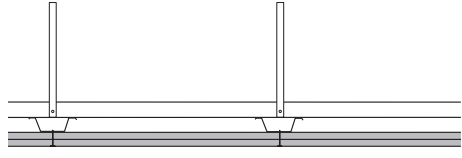
Fire Protection	Sound Insulation Rw	Wall Structure	No.
EI 30 / E60	28	Steel hangers 1x25 c/c 500mm Secondary profile FR 66/55 c/c 1200mm Primary profile 20/25/70/25/20 c/c 400mm 2x12 mm Swisspearl Multi Force	SC1  2x12 mm

## Balconies, Ceilings and Floors

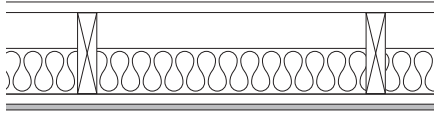
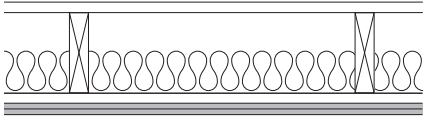
Fire Protection	Sound Insulation Rw	Wall Structure	No.
REI 30	32	Wood planks 22 mm, Wood beams 45 x 170 c/c 600mm, Rockwool 95mm, Wood planks 28x70 c/c 450mm 12mm Swisspearl Multi Force	F1  12 mm
REI 60	40	Wood planks 22 mm, Wood beams 45x170 c/c spacing 600 mm 95 mm stone wool Steel hat profiles S 25/28, c/c spacing 400 mm 2x12 mm Swisspearl Multi Forces	F2  2x12 mm

# Abutments

## Adjacent walls

$R'_w$  35-40 dB

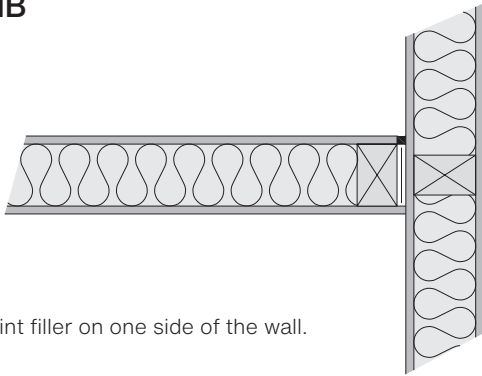

Abutment with joint filler on one side of the wall.

$R'_w$  44-48 dB

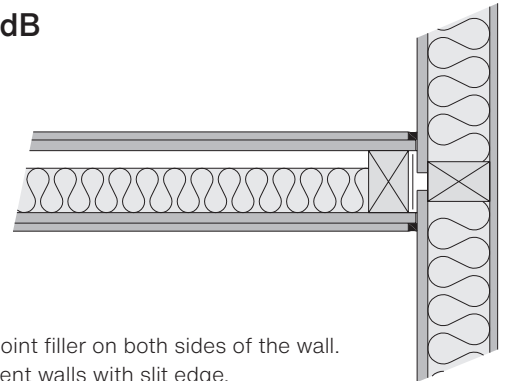

Abutment with joint filler on both sides of the wall. Boards in adjacent walls with slit edge.

$R'_w$  40-44 dB

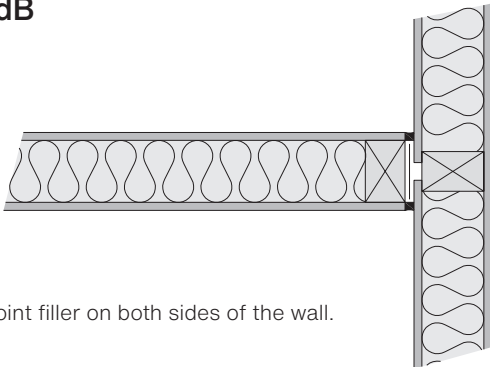

Abutment with joint filler on both sides of the wall.

$R'_w$  >52 dB

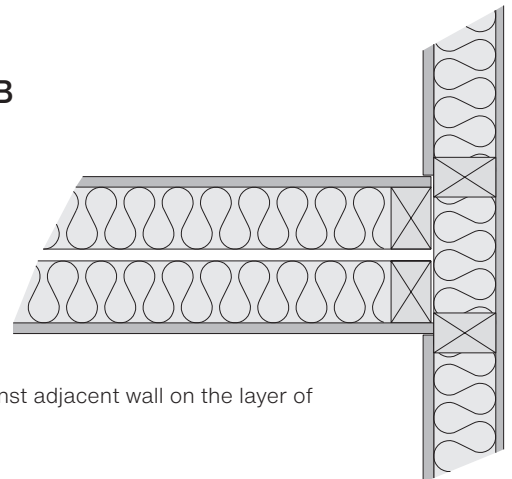

Abutment against adjacent wall on the layer of battens.

$R'_w$  40-44 dB

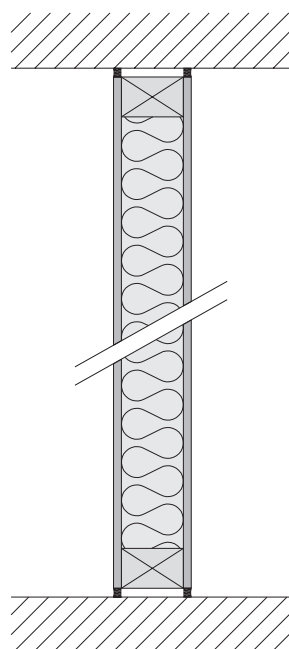

Abutment against floor, wall and ceiling with joint filler on both sides of the wall.

# Introduction

## Sound Insulation

### Planning on the basis of predetermined requirements for airborne sound insulation

Light partitions are always expected to have lesser sound proofing properties when installed in buildings than those measured in laboratories. The primary causes are sound transmission around the partition and variations in the installations. e.g. the coupling of edges in double walls as well as minor leaks. The difference between laboratory values and field values often amounts to 4-7 dB.

Usually the flanking constructions and the joints should be dimensioned and performed in such a manner that the total sound transmission around the partition does not exceed the sound transmission through the wall. With the basis, the values for  $R_w$  as specified in the tables on page 4-8, can be applied. In case of doubt, an evaluation by an acoustic expert must be conducted, for instance on the grounds of calculations according to EN 12354-1:2000 with the SEBASTIAN software. Likewise, calculations of other single number values than  $R_w$  can be made by an acoustic expert on the basis of the reduction figure per 1/3 octave.

Calculation of sound insulation for a combined construction, e.g. a wall with a door, must be carried out in accordance with EN 12354-1:2000 in order to achieve the most realistic values. The following offers some important guidelines concerning ways to avoid undesired sound transmission.

However due to the high variation between the sound insulation of partitions, as indicated in the tables on page 4-8, the guidelines do not apply to all possible situations.

All lightweight, flanking walls and ceilings, including formworks, must be separated from the partition. The same applies to floating floors. In light roof constructions, the direction of the rafters must be parallel with the partition, unless a special kind of elastic ceiling suspension is used.

Sound proof insulation for transmission through heavy, flanking walls and floors corresponds to at least the laboratory value for the light weight partition used. The partition must be tight (applies to surfaces, joints and lead-ins). Leaks might arise for instance in connection with pipe lead-ins and in fixing the partition into heavy building elements. Pipe lead-ins, etc. are sealed with mineral wool stopping and elastic joint filler from both sides. Electric installation sockets, etc. are supplied from each side. The sockets can be placed on either side of the wall, provided that there are no leaks in the cladding.

Along edges against adjacent building elements, elastic joints are placed on both sides of the wall. However, with  $R_w$  requirements below 44 dB, a joint on one side is sufficient.

### Sound Insulation Requirements

The sound insulation requirements in a building might be stipulated by the builder or the authorities. The airborne sound insulation values are important to determine in connection with the planning of the structural design, as it will be difficult and costly to improve the values, when the building element is completed.

Concerning pipe lead-ins, the fact that radiators might transmit airborne sounds from one room to another, if they are connected with short, unbroken heat pipes must be taken into account.

Sound transmission through ventilation channels or fresh air intakes without appropriate sound reduction may decrease the sound proof insulation considerably. The risk of such reduction is greatest between fittings connected to the same string and between fresh air intake with a spacing less than 2 m. To avoid sound transmission via roof spaces most efficiently, the partition must be lead all the way to the ridge. Alternatively,

# Sub-Construction

## Fixing and Support Instructions

Swisspearl Multi Force must be fixed to a dry and even sub-construction with a max support width of 600 mm (c/c distance). Max distance between fixing points must not exceed 400 mm.

All vertical board edges are to be supported by studs. Horizontal board edges must always be supported by a batten or a board material strong enough to fix the screws for fixation. Swisspearl MF boards are fixed with butt-joints.

If the wall construction is made of several layers of e.g. chip-boards under the Multi Force boards these should have the same width 900 mm or 1200 mm. The underlying boards should be fixed in an upright position according to the supplier's recommendations, and the next layer should be staggered. Regardless of the number of layers the max support distance is 600 mm c/c.

In case of 2 layers of Multi Force boards there must be a min 150 mm overlap at horizontal joints. Timber studs are to be made of planed wood with full size edges in dimensions according to the actual load (min 45x45 mm).

Steel studs should be made of cold rolled steel according to EN10327:2004 with a min thickness of 0.56 mm, and hot dipped galvanized with a coating thickness min 20  $\mu\text{m}$  (275 g/m<sup>2</sup>).

### Acoustic Insulation

For achieving a good sound reduction a felt material is fixed onto the sub-construction at the connections to floors, walls and ceilings. For increasing the sound reduction the edges of the inner boards can be sealed with a mastic or silicone sealant.

All edges must be supported. Joints should be staggered min 300 mm, also by multiple layers. Joints may not be flush with door and window openings. By multiple layers this only counts for the outer board. Vertical joints should be established on the same stud on both sides of the wall.

# Surface treatment

## Painting and Surface Treatment Guidelines

### Before painting

Cleaning the boards from dust is very important in order to get good adhesion for the paint. Screw heads and scratches should be filled and the beveled joints left visible. The boards need to be dry for painting.

### Painting

Swisspearl Multi Force can be painted with paints suitable for concrete surfaces, such as latex or acrylic based paints. Oil and alkyd based paints that don't have resist alkaline do not work with Swisspearl Multi Force. Follow the paint supplier's instructions.

### Water resistant surface

For a dirt and water resistant surface, we recommend that Swisspearl Multi Force is treated with a silane / siloxane sealer or a concrete impregnator / sealer. The finishing look will be transparent, matt surface with the boards' natural color.

### Outdoor use

Swisspearl Multi Force can be used outdoors in places where it is protected from rain. These applications include such as soffits, partitions between glazed balconies, balcony ceilings and shelters. In these applications a 12 mm thick Swisspearl Multi Force is to be used. The boards can be painted with alkali resistant paints meant for concrete surfaces for outdoor use. Proven solutions include socle paints such as Tikkurila Yki. Painting needs to be done according to paint supplier's instructions.



# Installation

## Fixing and Support Instructions

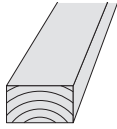
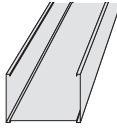
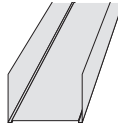
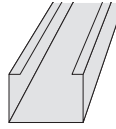
	Wooden Frame	Steel Frame	Steel Frame	Steel Frame
				
Dimensions	45x45 mm 45x70 mm 45x95 mm	R 45/40 R 70/40 R 95/40 Material thickness 0,56 mm	SK 45/37 SK 70/37 SK 95/37 Material thickness 0,56 mm	FR 45 FR 70 FR 95 Material thickness 1,2 mm
Application	Vertical posts	Vertical rails	Rails near ceilings, floors, and floor joists	Stabilising rails for doorways

## Supports / Wall Heights

Studs	Board layer(s)	Max Wall height
Wood 45x45 mm	1 layer	3000 m
Steel R45	1 layer	3000 m
Wood 45x70 mm	1 or 2 layers	4000 m
Steel R70	1 or 2 layers	4000 m

### Support and fixing distances – Steel Frame

Perimeter frame: Steel rails are fixed per 400 mm with screws appropriate for the substrate.

### Fastening

Swisspearl Multi Force is fastened with screws (see below table). No pre-drilling is needed. Normally the screw heads are fixed to the level of the board surface. If a blind fixation is desired the screw heads can be countersunk 0.5-1 mm.

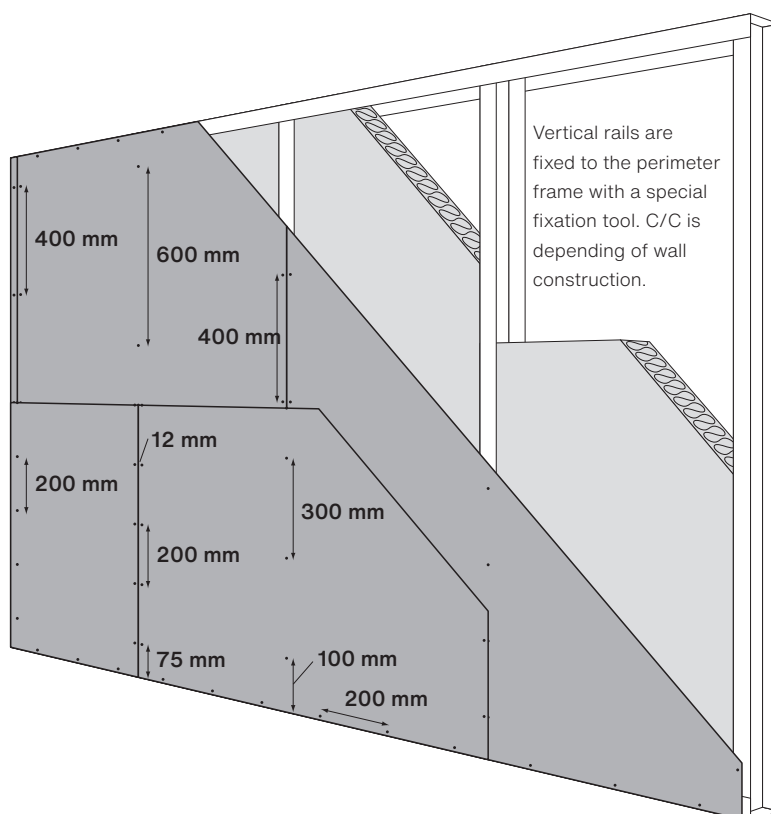

# Fastenings

## Fixing and Load-Bearing Guidelines

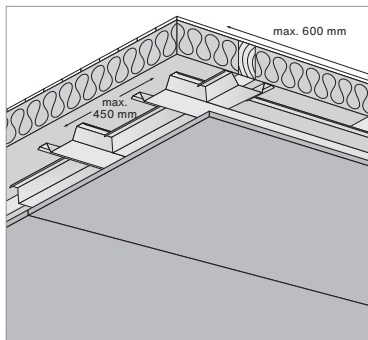
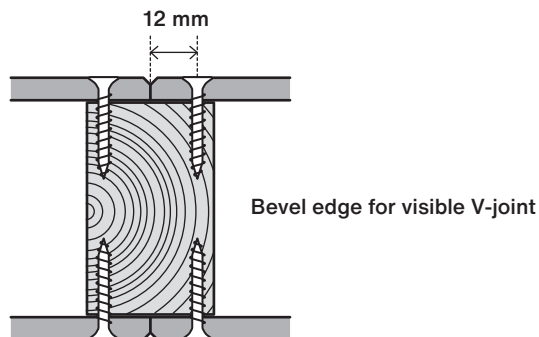

Floor division

### Screw distances

Partition walls and ceilings	Distance
Supported edges	200 mm
Intermediate supports	300 mm
Vertical corner distance	75 mm
Min. edge distance	12 mm

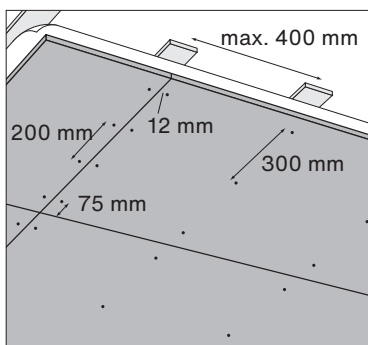

Ceiling

Fixing on steel max 1.2 mm	Fixing on steel	Fixing on wood	Fixing on wood
Board layers	Screw	Board layers	Screw
≤12 mm	SCR-S 4.2x30 mm Universal	≤12 mm	SCR-W 3.9x38 mm Universal or SCR-W 4.2x35 mm Yellow Plated
12-24 mm	SCR-W 3.9x38 mm Universal	12-24 mm	SCR-W 4.2x45 mm Yellow Plated

### Fastenings

Swisspearl Multi Force boards are strong and durable. They can therefore support a wide range of interior items that would normally require reinforcement behind the board. When reinforcements are required, they can be provided as fixtures, reinforcement sheet metal or plywood.

#### 1. Without reinforcement

Normal interior items that do not require reinforcement include cabinets, shelves and handrails. The table shows examples of fastenings and dimensioning loads for 9 mm thick boards.

#### 2. With reinforcement sheet metal or plywood

When loads are greater than above, fastenings need to be reinforced using sheet metal or plywood sheets between the studs. Examples: heavy shelves and wash basins.

Fastenings	Max load kg Shear load	Max load kg Pulling	Examples
	7,5	-	
	15	-	Mirrors, hooks, light shelves
	35	17,5	
	60	37,5	
	85	30	Cabinets, light shelves and hooks
	90	37,5	

# Processing

## Safety and Handling Guidelines

### Safety

As for all other building materials safety precautions must be taken into account and local laws and regulations must be observed.

Swisspearl Multi Force boards do not contain any dangerous or harmful substances, nor do they give off any fumes that could be a health hazard.

Today, no specific requirements exist as to the methods and tools used when installing the Swisspearl Multi Force boards.

Cutting and drilling are however subject to dust development, and proper precautions must be taken. Dust from fibre cement boards is characterized as mineral dust and a prolonged exposure to this may cause lung disease.

### Cutting

Cutting to size may be done with normal slow running (2000 rpm) circular saw. Sharp edges are made with fast running diamond tipped tools. Dust exhaustion must be employed. For the best result the boards should be cut backside up.

### Swisspearl sawblades

Diameter	ø160	ø190	ø216	ø250	ø300
Width [mm]	2.4	2.4	2.6	2.6	2.8
Hole size [mm]	20	30	30	30	30
Rpm	4800	4000	3500	3000	2800

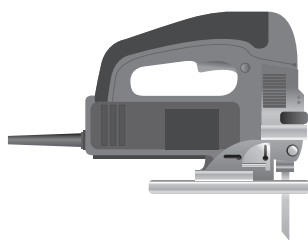

Cut-outs and bigger holes may be made with a jigsaw equipped with a hard metal, bi-metal or diamond tipped blade. A min 8 mm hole is to be drilled at the inner corner to avoid cracking of the board. Smaller holes can be made with a keyhole saw.

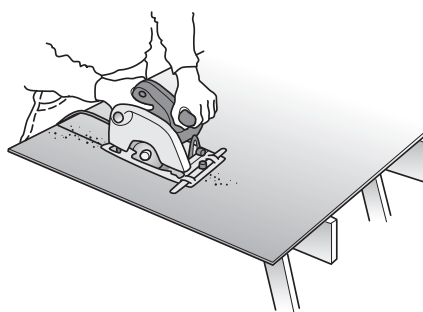

As an alternative it is possible to score the boards on the front side with a hand-scriber and break them over a sharp edge. Fins should be removed before fixing the board.

Cut-outs may be made with a jigsaw equipped with a hard metal, bi-metal or diamond tipped blade. A min 8 mm hole is to be drilled at the inner corner to avoid cracking of the board. Wall ducts for pipes etc can be made with a keyhole saw (diamond tipped or HHS bi-metal).

# Handling and Storage

## General information

### Handling and Storage

Swisspearl boards should be stored on a flat and dry level surface. The plastic cover is for dust protection only during transportation and should be removed upon arrival at the building site. Hereafter the pallets should be kept under a roof or covered by a tarpaulin leaving the possibility of ventilation around the boards.

The boards must be lifted off the pallet and not drawn over the next board. This will cause scratches and damages on the surface. Note! Max 5 pallets in one stack and always on a substrate with a sufficient carrying capacity.

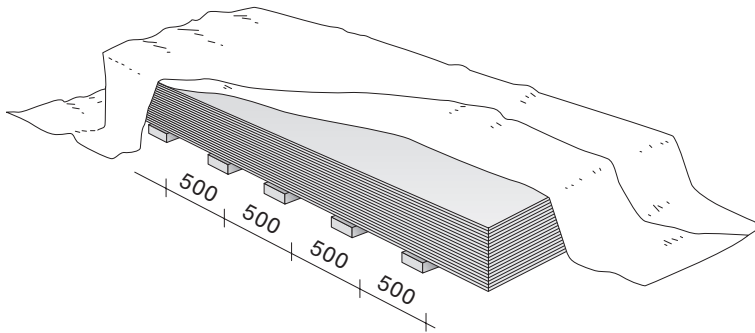

### Service

If you have any questions regarding the Swisspearl functional boards, your local Swisspearl representative is ready to assist you with advice and guidance.

### Warranty

Warranty conditions can be commissioned at Swisspearl B.V.

# Info

## About Swisspearl



Swisspearl is one of the leading European manufacturers of multi-capability fibre-cement building products. Our products and solutions add exciting new design opportunities for moulding attractive, durable settings for people's lives. But Swisspearl is more than mere products. We also help make all kinds of design and construction projects easier – as well as more profitable, inspiring and effective.

And for us, all construction also involves building relations with people, making your day better, and helping you make the day better for others. Making it a day to remember.





**Swisspearl Sverige AB**

Västberga allé 5, 10 tr  
Box 42013  
12612 Stockholm  
Sweden  
+46 (0)8 506 608 00  
info@se.swisspearl.com

**swisspearl.com**