

Fixing and Storage Guide Corrugated Sheet

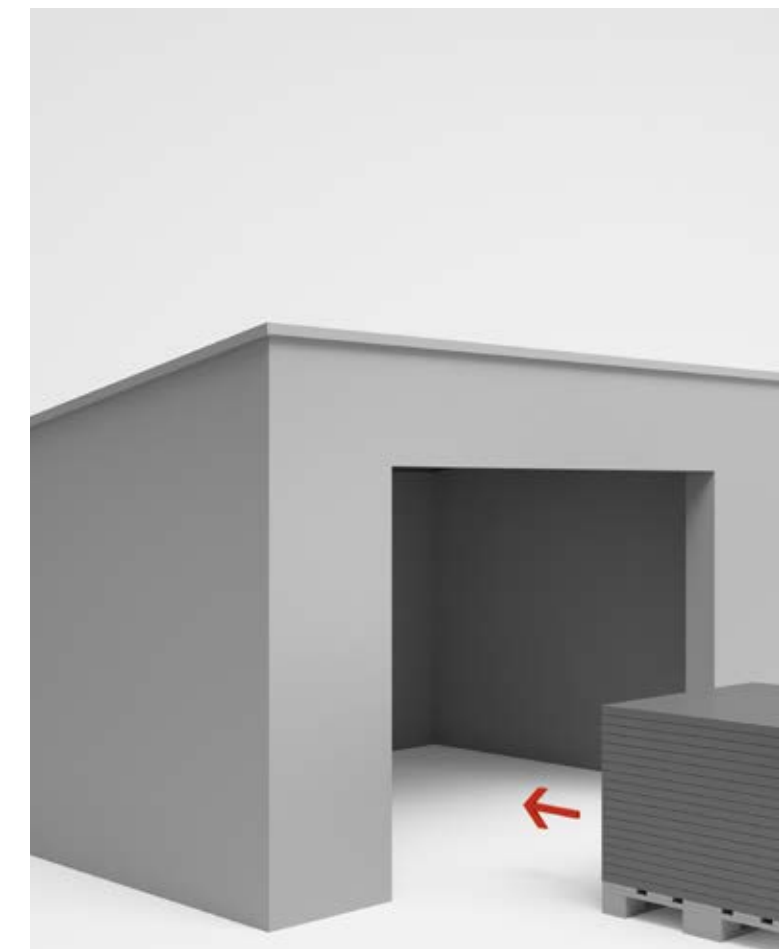

Overhangs

Sufficient overhangs must be allowed at the eaves to ensure that rainwater discharges into the gutter. Verges must be overhung by one complete corrugation unless a bargeboard is used.

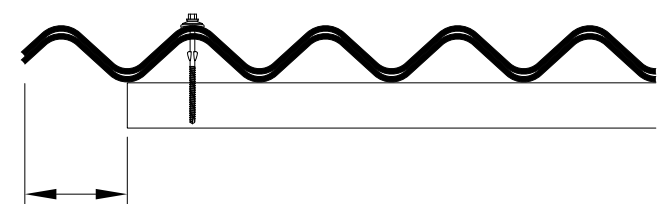
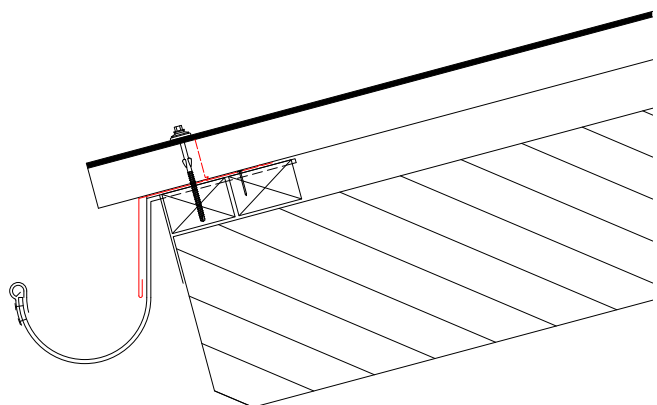

Side Laps

Sealing

Where appropriate, butyl strip sealant should be positioned as shown. Use 8 mm diameter butyl strip for Cemsix

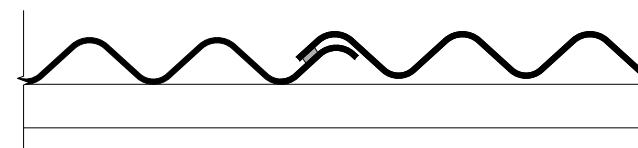

End Laps

The minimum end lap for Cemsix is 150mm, fixed as shown in the section below.

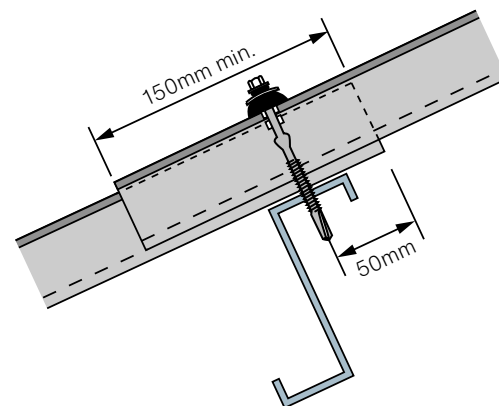

Where double sealing is necessary with 300mm end laps, the second butyl strip should be positioned 100–200mm below the fixing.

Lap Details

Extra care and attention to lap detail is required for low pitched roofs - please see tables below.

Sheltered to moderate sites

Less than 56.5l/m² of wind-driven rain per spell

Minimum roof pitch	Minimum end lap	End laps treatment	Side laps treatment
≥ 22.5	150 mm	Unsealed	Unsealed
≥ 15°	150 mm	Sealed	Unsealed
≥ 15°	150 mm	Sealed	Sealed
≥ 10°	300 mm	Sealed	Sealed
≥ 5°*	300 mm	Double Sealed	Sealed

Moderate to severe sites

More than 56.5l/m² of wind-driven rain per spell

Minimum roof pitch	Minimum end lap	End laps treatment	Side laps treatment
≥ 25°	150 mm	Unsealed	Unsealed
≥ 17 1/2°	150 mm	Sealed	Unsealed
≥ 15°	150 mm	Sealed	Sealed
≥ 10°	300 mm	Sealed	Sealed
≥ 5°*	300 mm	Double Sealed	Sealed

*The minimum pitch for Cemsix corrugated sheets is 5°. On roof pitches between 5° and 10° the maximum slope length is 15 m. For longer spans please contact Swisspearl for advice.

Installation

Whilst Swisspearl profiled sheeting is easy to install, the following guidelines should be observed:

- The sheets should be installed smooth surface up.
- The sheets should be cut with a hand saw or slow speed reciprocating power saw.
- All fixing holes should be drilled, not punched, and should provide adequate clearance for the fastener shank. (minimum 2mm)
- There should be two fixings per purlin or rail covered at the fixing points, as shown in the diagram below.

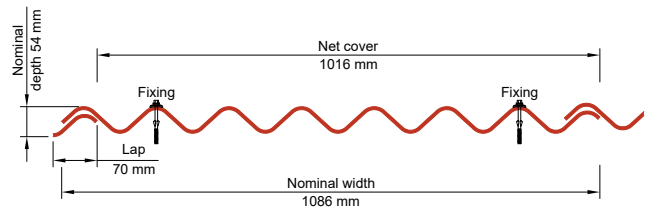

- When using power tools in a confined area, dust extraction equipment is advisable.
- The dust and swarf generated when working with the sheets does not require any special handling requirements other than normal good housekeeping to maintain a clean working area.

Fixing

The correct fixing of a sheet is important in order to avoid premature failure, corrosion or leaks in a roof. Many factors influence the fixing of a roof, such as the purlin or rail type and the nature of the roof in question. Particularly important is the type of fastening system used and compliance with the manufacturer's recommendations.

Top fix fasteners are generally used to fix Swisspearl Cemsix sheets on a roof as they provide a quick and effective one stage fixing operation. Follow the recommendations of the fastener manufacturer regarding maximum roof pitch, minimum purlin thickness etc. Top fix fasteners should be installed using the recommended soft setting power tool to ensure the fasteners are correctly tightened.

Checking the top fix fasteners for tightness



Where top fix fasteners are not used, 8mm diameter fasteners are used for Cemsix. The fibre cement sheet must be pre-drilled with a 2mm clearance hole, using drive screws, the holes must be located centrally on the crown of the sheet. For hook or crook bolts, the holes should be 4mm upslope of the back edge of the purlin. In all instances, Seala washers and caps should be utilised to ensure adequate weather protection.

Storage and handling

Storage (general)

Profiled sheets should be stored as close as practically possible to the area of works, on a firm level base, using the profiled bearers (on which the sheets are delivered) to raise the sheets off the ground. Sheeting stacks should generally not exceed 1200mm high unless a level concrete base is available, in which case, the maximum height is 1500mm. A separate stack should be made of each length of sheet; if this is not possible, stack with longest sheets at the bottom and the shortest at the top. It is important when stacking Cemsix sheets on site that the smaller 'under rolls' are all on the same side of the stack. Sheets should always be stored weather (smooth) side upwards.

Stacks of sheets should not be stored in full sun during the summer months as the differential temperature across the sheets can result in unacceptable stresses in the sheets and can lead to edge cracking.

If sheets are to be retained in the packs for more than 2 months, they should be stored inside a building where they can be protected from extreme variation in temperature and moisture.

Ingress of moisture into packs of profiled sheets may cause efflorescence staining, bowing during installation or permanent distortion.

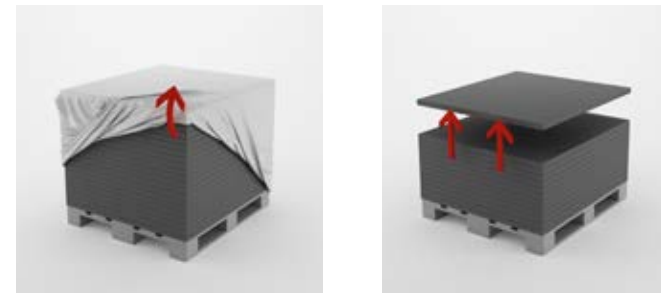

Storage (natural grey sheets)

The plastic wrapping should be retained for as long as possible to control the environment around the sheets. Once the pack has been opened, or if the wrapping is damaged and allowing the ingress of water, the sheets should be stored under cover.

Storage (coloured sheets)

Coloured sheets should be stored under cover at all times, preferably inside a building, but if this is not available they can be stored under a tarpaulin. The tarpaulin should be spaced off the top and sides of the sheets to allow effective air circulation and avoid condensation.

The plastic wrapping on coloured sheets is only designed to protect the sheets in transit. It should be removed and carefully disposed of as soon as possible.



Swisspearl GB Ltd

Unit 1a, Birchwood One Business Park
Birchwood, Warrington
Cheshire WA3 7GB
United Kingdom
+44 (0)203 372 2300
info@gb.swisspearl.com

swisspearl.com