

SWISSPEARL

DIM Design & Installation Manual

Swisspearl Berona Slate Range





Table of Contents

Swisspearl	4
Product Specifications	6
Climatic Influences	8
Health and Safety	10
Storing and Handling	10
Processing (Cutting and Drilling)	10
Pre-Installation	11
Installation	12
Maintenance	27
General Information	28

Swisspearl

Swisspearl Berona, Berona Xtra, Berona Stonedge & Berona Structured – the perfect solution for a successful roofing project. For decades, the durable and largely maintenance-free Swisspearl slates have adorned Irish roofs.

Swisspearl slates are thoroughly tested and comply with the following standards:

- EN 492
- ISO 9001 (“Quality Management System”)
- ISO 14001 (“Environmental Management System”)

Swisspearl is one of the leading European manufacturers of multi-capability fibre cement building products. Our products and solutions add exciting new design opportunities for moulding attractive, durable settings for people’s lives. But Swisspearl is more than mere products. We also help make all kinds of design and construction projects easier as well as more profitable, inspiring and effective. And for us, all construction also involves building relations with people, making your day better, and helping you make the day better for others.

Product Information

Swisspearl fibre cement is a modern building material made from natural and environmentally friendly raw materials. The technology has been developed by Swisspearl, having more than 125 years of experience within the manufacture of fibre cement. Our wide experience ensures a sustainable product which has accumulated all the advantages of fibre cement. Swisspearl prides itself on manufacturing fibre cement slates which achieve the highest approvals from local, national and international agencies in the fields of product quality and sustainability.

Warranty

The Swisspearl warranty terms can be found at swisspearl.com/en-ie under Downloads.

Disclaimer

The information and recommendations contained in this Design & Installation Manual (“DIM”) are offered as a service to architects, constructors, installers and other persons involved with our products and are not intended to relieve them from their own responsibility. The information and recommendations provided herein are believed by Swisspearl Group to be accurate at the time of preparation of this DIM, or obtained from sources believed to be generally reliable. Swisspearl Group makes no warranty concerning the accuracy of the content of this DIM and shall not be liable for claims relating to any use regardless of whether it is claimed that the information or recommendations are inaccurate, incomplete, or otherwise misleading. The information and recommendations herein are intended to be used with the judgment and experience of professional personnel competent to evaluate the significance and limitations of the material contained. Swisspearl Group expressly disclaims any guarantees or warranties, expressed or implied, for anything described or illustrated herein and assumes no responsibility or liability for damages of any kind, including – without limitation – bodily harm, injury or damage to property inferred from this DIM or the use of the materials described herein.

Life-cycle assessment (LCA)

Swisspearl’s Czech produced fibre cement slates have been awarded an Environmental Profile Certificate by BRE Global

Ecopoint scores from cradle to grave for 1 m² of the Swisspearl range of slates over a 60 year life range from 0.34 to 0.51 depending on the element specified.

Quality assurance

The Berona range of slates are manufactured in accordance with a quality assurance system ISO 9001 and to the requirements of IS EN 492: 2004 product specification for fibre cement slates and their fittings.

Environmental Management

The Swisspearl range of slates are manufactured in a factory which complies with the requirements of ISO 14001: 2004, and has been awarded certificate number E-0942C/25.



Product Specifications

Datasheet

Tolerances:			
Length	mm	± 3.0 mm	EN 492
Width	mm	± 3.0 mm	EN 492
Thickness	mm	+1.0 - -0.4 mm	EN 492

Berona	smooth surface & square edges	
60x30	Slate Black	Slate Graphite
Colours	✓	✓
EN 492	✓	✓
Thickness	4 mm	4 mm
N° per pallet	1,000	1,000
Gross weight kg/pallet	1553	1553
N° slates per m ² - headlap 110 mm	13,6	13,6
Ridges 75° 90° 105° 120° 135°	✓	✓

Berona Stonedge	smooth surface & dressed edges
60x30	Slate Graphite
Colours	✓
EN 492	✓
Thickness	4 mm
N° per pallet	1,000
Gross weight kg/pallet	1553
N° slates per m ² - headlap 110 mm	13,6
Ridges 75° 90° 105° 120° 135°	✓

Berona Structured	structured surface & dressed edges	
60x30	Slate Graphite	Welsh Blue
Colours	✓	✓
EN 492	✓	✓
Thickness	4 mm	4 mm
N° per pallet	1,000	1,000
Gross weight kg/pallet	1534	1534
N° slates per m ² - headlap 110 mm	13,6	13,6
Ridges 75° 90° 105° 120° 135°	✓	✓

Berona Structured 50	structured surface & dressed edges	
500x242	Slate Graphite	
Colours	✓	
EN 492	✓	
Thickness	4 mm	
N° per pallet	1320	
Gross weight kg/pallet	1388	
N° slates per m ² - headlap 110 mm	21.3	
Ridges 75° 90° 105° 120° 135°	✓	

Product Compatibility

The Swisspearl range of slates are compatible with most common building materials, except those vulnerable to alkaline attack. When materials such as aluminium are used as flashings or gutters they should be protected and maintained with bituminous paint if they are to be subject to water run-off from the slates

Fire Resistance

Swisspearl Berona, Berona Xxtra, Berona Stonededge & Berona Structured slates hold the following ratings: BS 476: Part 2: 1989 and BS 476: Part 7: 1987 Fire Propagation Index (I) of 0.9, a sub-index (ii) of 0.3 and a Class 1 surface. Class 0 surface - as defined in the national Building Regulations. BS 476: Part 3: 1958 EXT. SAA BS 476: Part 3: 2004 Class P60 Please, note that slight curling may occur in newly laid slates as a result of climatic conditions. However, such curling will wane over time and does not compromise the weather resistance of the products.

Dry Rot Resistance

The acrylic coating enables the Swisspearl Berona, Berona Xxtra, Berona Stonededge & Berona Structured slates to resist dry rot attacks as well as reduce the potential growth of other vegetation such as moss and lichen.

Effects of chemicals

During tests the range of Swisspearl slates have been found to have a good resistance to chemical attack, however it should be noted that prolonged exposure will cause surface degradation. In areas where this may be excessive please consult Swisspearl Ltd. for further advice.

Tolerances

The Swisspearl range of slates are made to the following dimensional tolerances in accordance with IS EN 492: 2004. Length or width: +/-3.0 mm. Thickness: 4 mm + 1.0 mm, - 0.4 mm

Strength

The Swisspearl range of slates exceed the requirements of IS EN 492: 2004 giving an average bending moment greater than 50 Nm/m.

Apparent Density

The Swisspearl range of slates have an apparent density of 1600 kg/m³ when tested to IS EN 492: 2004 section 7.3.1.

Identifying the Slates

Approximately 25% of the slates are equipped with an identification number on the underside using the following format: B104206NTB2.

- The first character denotes the factory of origin
- The first six figures denote the shift and year of manufacture
- The characters "NT" denote the application of non-asbestos technology, and
- The final two characters denote the production and painting lines used for manufacture.

Small vs. Large Roofs

This Installation Manual applying to Swisspearl Berona, Berona Xtra, Berona Stonedge & Berona Structured slates is based upon the advice and guidelines provided by the Irish code of practice for slating and tiling SR82:2017, BS5534:2014 Code of practice for slating and tiling due to northern Ireland. However, please be aware that the size of a roof affects its behaviour. Thus, the minimum recommendations in SR82, as well as in the Installation Manual, apply only for roofs with a roof slope (measured by horizontal projection) not exceeding 6 metres.

This corresponds to a rafter length of approx. 6.5 metres at 25° pitch or 8.5 metres at 45°.

With roofing areas exceeding the above size, additional weather resisting provisions (e.g. increased slate head laps, counter battens, superior roofing underlay, and boarding out) must be considered. Ensure that your method complies with the Regulation C3.3 of the Irish Building Regulations 1997 as well as the applicable building regulations in Ireland and Northern Ireland.

Capillary Action

Capillary action: the force that causes liquids to rise between close-fitting materials.

Capillary action can often be seen in slated roofs, as liquids rise between the overlapping slates to a vertical level of about 25 mm.

Elements that can increase the extent of capillary action are:

- Roof pitch: the lower the pitch, the greater the capillary action
- Dust particles between the slates
- Site exposure (See “Climatic Influences” below)

It is possible to calculate an approx. water level between the overlapping slates of any roof, taking into consideration the above elements. Please, contact our well-trained staff who will be ready to assist you in this process.

Climatic Influences

Ireland counts among the windiest countries in Europe with a medium to high rainfall rating with a significantly higher rating from east to west and from low to high locations. These factors must be taken into consideration when building in Ireland.

Rainfall Effect

The rainfall effect from wind-driven rain cannot be controlled, but during the design phase of a house, it is possible to take some precautions to limit this effect. Such precautions might be; pitch, rafter length, size of slates, head lap or a sub-construction fitted for the purpose.

When designing your house, the map opposite can serve as a guide to how exposed your site is and can thus, help you to make important decisions concerning the design of your new house. Please, be aware that the map is merely an indicator as other factors may impact the degree of exposure to wind-driven rain, e.g. proximity to coastal areas, near river valleys or on hilltops.

Wind Effect

The wind effect is generally highest in coastal and urban areas compared to rural areas with towns and cities, however, the tougher the landscape, the lower the wind speed. Wind speed is reduced by frictional resistance that occurs e.g. when in contact with a rough landscape. Just as with wind-driven rain, wind speed cannot be controlled, but limited through the design of a house.

As illustrated, the design pitch of a house can either increase or reduce the effect of wind and wind-driven rain upon a house. Due to frictional resistance, the wind is slowed down when hitting the face of the house and at the same time, an amount of pressure is created. Some of the wind also deflects around corners, end walls and roof tops, thereby creating negative pressure, i.e. suction. The degree of suction depends on wind speed and height of roof pitch;

- Pitch <30°: windward slopes can be subjected to severe suction
- Pitch >35°: windward slopes are subjected to positive pressure, although area near the ridge may still be subject to a degree of suction
- Leeward slopes are always subjected to suction.
- Suction is always highest at the perimeters of the roof as well as other areas interrupting the roof surface such as ridges, eaves, verges, hips, abutments and valleys, etc.

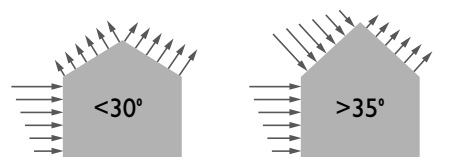

When affected by high wind speed (pressure/suction), underlay overlaps may start to work/move creating holes and cracks through which the wind can enter the roof space. Such air rushing through the roof space may cause a serious increase of the water rise by capillary action on the slates.

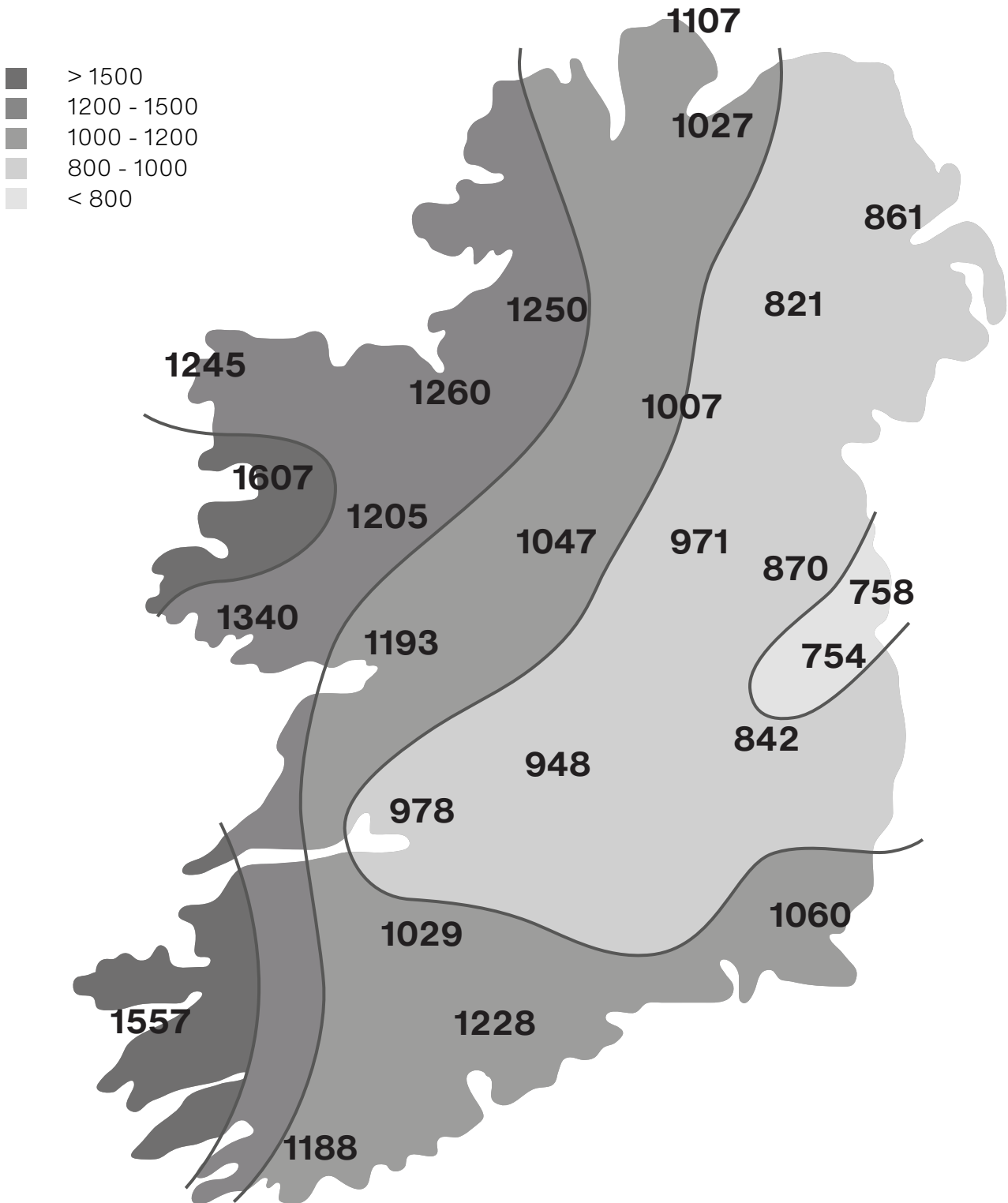

Mean Annual Rainfall Totals

Note : This map is based on data from the Irish and Northern Irish Meteorological Services.

Health and Safety

Before commencing work on any project reference should be made to the HSA code of practice for safety in roofwork. This guide details working at height, handling, protecting the public, risk assessment and Construction Design & Management.

Storing and Handling

Swisspearl slates are delivered on pallets with a polythene cover. Ideally, the pallets should be stored indoors or under cover until they are to be used. However, the slates can be stored outdoors for a short period of time. If this is the case, the polythene cover, which is for dust protection only, should be removed from the Swisspearl slates upon arrival at the building site. Carefully stack the slates separated by timber bearers, battens or boards with the lowest layer on a flat and dry level surface. Care should be taken to ensure this area is free of running water during rain and no ponding can occur. Slates **MUST NOT** be allowed to become wet when in packs or banded together, as efflorescence and staining can occur. Keep the pallets under a roof or covered by a tarpaulin leaving the possibility of ventilation around the slates and avoiding water accumulation between the slates surfaces, as this may cause efflorescent staining on the slates. Lift the slates off the pallet and do not draw over the next slates, as this will cause scratches and damages to the surface.

NOTE! For large building projects, it is recommended to schedule material delivery from the merchant as required, thereby avoiding the storage of large quantities.



Processing

Safety

As with all other building materials, safety precautions must be taken into account and local laws and regulations must be observed. Cutting and drilling are subject to dust development, and proper precautions must be taken. Dust from fibre cement boards is characterised as mineral dust and a prolonged exposure to this may cause lung disease.

Drilling

Holes are drilled from the front side with a sharp, pencil point, 4.5 mm steel drill bit. Ensure to keep the bit sharp throughout the drilling to extend the life of the drill bit. Always put an underlay, e.g. a wood chipboard, under the Swisspearl slates in order to achieve neat drilling holes. In order to save time, it is possible to hole blank slates in stack bundles of 10 at a time.

After drilling, ensure to immediately remove all excessive dust development from the slates to avoid cement staining of the slates when exposed to rainfall.

Cutting

Swisspearl slates can easily be cut to fit the desired size.

Swisspearl recommend one of the following methods:

- Using a scribing tool, score the face of the slate and break the slate over a straight edge, or
- Using a slate guillotine, place the slate face up and cut. This method leaves the slates with a straight, chamfered cut edge, bevelled away from the face of the slate, or
- Using hand scissors/punch, cut the slates to the desired size.
- Using a bench saw with a diamond dusted blade, cut the slates to the desired size. This method can be applied when cutting large quantities of slates when applying this method dust extraction is necessary.

NOTE! We do not recommend angle grinders for cutting of the slates as this causes high dust development.

After cutting of the slates, additional fixing holes must be drilled. Holes must not be placed less than 20 mm from the edge of the slate.

Make sure to immediately remove all excessive dust development from the slates to avoid cement staining of the slates when exposed to rainfall.

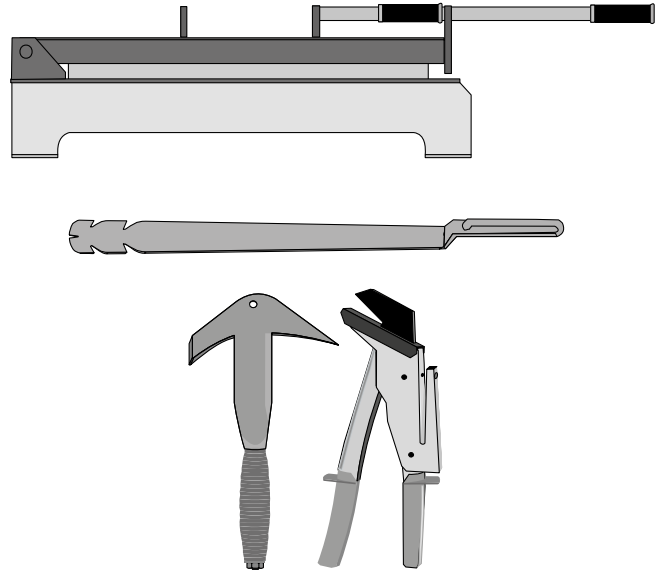

Pre-Installation

Before you set out to install the slates, it is important to carefully inspect the area to be roofed in order to plan the roofing process leaving minimum work for you and minimum cutting and drilling of slates.

Ensure that:

- All horizontal lines are regular and correct
- All perpendicular lines of the slates are correctly aligned
- All battens are fixed according to the recommended gauge
- All battens >1200 mm are fixed to each rafter or supported in straight lines, parallel with the ridge/top layer/right angles to the line of drainage
- All joints between battens are square-cut and butted in the middle of the support
- All batten ends are splay-nailed
- All valley boards are correctly levelled
- All valleys are appropriately sized
- All underlay overlaps are correctly dimensioned and secured
- Underlay is properly supported around eaves

In the event of penetrations to the underlay, including tears or punctures, these must be securely sealed or repaired prior to roofing. Penetrations can be closed with sealing tapes or an underlay "cover patch".

Place necessary sealing tape or cover patch as follows:

- beneath the underlay lap above by at least a head lap distance
- covering the rafters on both sides of the penetrated area
- lower edge extending beyond the penetrated areas by at least a head lap distance
- secured under a batten.

Installation

Swisspearl recommend the installation of their range of slates as follows:

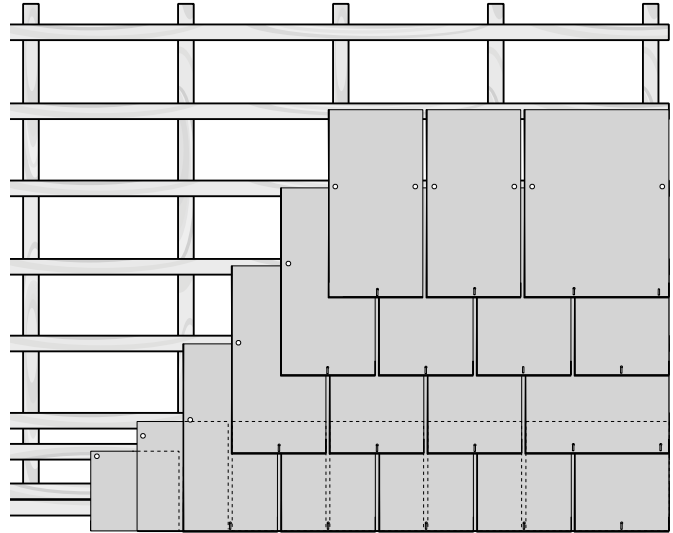

Setting out

1. Batten out roof, starting at the eaves, according to specified head lap for the particular slates. Ensure that the batten gauge is half the difference between the length of the slate and the head lap.
2. Place the first batten ensuring a 50 mm eaves slates overhang of the gutter.
3. After calculating the desired verge overhang, accurately mark out the width of each slate and chalk the perpendents onto the battens, ensuring a 4 to 6 mm gap between the slates.
4. Cut and head nail the slate underleaves along the entire length of the eaves.
5. Centre nail the second layer of slate underleaves. Ensure that these slates are cut to the same batten, using slate-and-a-halves at the verges. Holes must be drilled in the slates-and-a-half half a slate-width in from the verge and 20 mm up from the tail. Place the stem of the copper crampion in the hole to restrain the tail of the verge slate in the first full-length layer of slates.
6. Fix the third layer of slates – i.e. the first full-length layer – by driving two nails for each slate firmly, but not too tightly, into the batten.
7. Place a crampion at the tail of each slate with the disc secured between and below the edges of the two slates in the below layer. Ensure that the stem of the crampion peeps out through the hole in the tail of the slate in the next layer.
8. Bend the stem of the crampion 90° down the slope of the roof to restrain the tail of the slate.
9. At the verge of this layer, install the first full-length slate-and-a-halves. This requires drilling three nail holes on the batten line and two additional holes for crampions. Drill the holes 50 mm in from the verge and 20 mm plus the gauge up from the bottom edge of the slate.
10. Fix the next layers of slates, trimming to verges, hips, valleys and ridges as necessary.

Note! The remaining slate-and-a-halves to be used require a third hole to be drilled for the crampion of the single-width verge slate in the next layer. Drill this third hole a slate width in from the verge and 20 mm plus the gauge up from the bottom edge of the slate.

If you need any guidance in slating your roof, please contact our well-trained staff, who will be ready with good advice.

Installation Details

The installation details in this Installation Manual for Swisspearl slates apply only to standard roofs as described above under “Small vs. Large Roofs”. For installation of Swisspearl Berona slates on non-standard roofs, please consult the latest version of SR82 and BS5534.

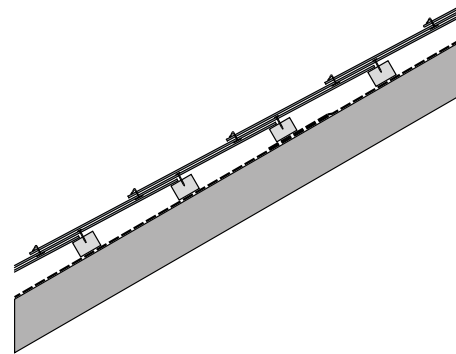
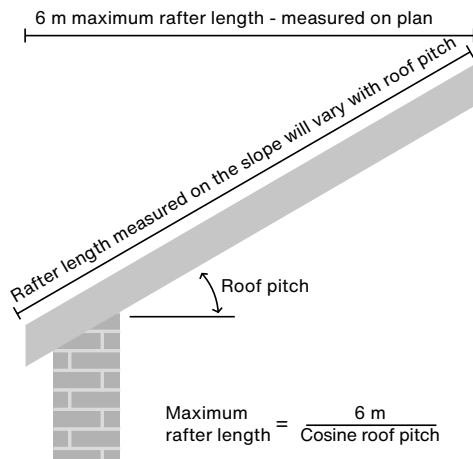

Pitches & Laps

When roofing, two types of laps exist:

Headlap: The distance by which the head of the slate is overlapped by the slate 2 courses above it.

Side lap: The side distance by which the slate overlaps the slate in the next layer below – generally half the width of the slate.

As described under “Climatic Influences”, the exposure of the site to wind-driven rain and wind must be taken into account when roofing. Below, you will find recommendations for minimum pitches and laps for standard roofs, but please be aware that some circumstances (see “Climatic Influences”) may cause a normal exposure to become a severe exposure and the minimum recommendations for pitches and laps may not ensure full weather protection of your house. Ensure that the dimension of the head lap is never less than the minimum value specified in the tables.

Normal exposure: Minimum pitches and laps			
Slate	25°-30°	30°-35°	> 35°
600 x 300 mm	110 mm	100 mm	90 mm
500 x 240 mm	110 mm	100 mm	100 mm

* The use of high-performance roofing underlay is recommended.

Severe exposure: Minimum pitches and laps			
Slate	25°-30°	30°-35°	> 35°
600 x 300 mm	110 mm*	110 mm	100 mm
500 x 240 mm	110 mm	110 mm	100 mm

* The use of high-performance roofing underlay is recommended.

Standard double lap fibre-cement slates should generally be laid at pitches greater than or equal to 25°.

Some double lap fibre cement slates may be laid at pitches less than 25° but no less than 20°. For pitches less than 25° contact Swisspearl for fixing recommendations.

Coverage

When determining how many slates are required to cover a particular roofing area, please be aware that this depends on: size of slate, length of specified head lap and pitch (lower pitch equals smaller roof slope area).

Quantity per square metre		
Headlap	600 x 300 mm	500 x 242 mm
90 mm	13.1	N/A
100 mm	13.4	20.8
110 mm	13.6	21.3
150 mm	14.8	N/A

Approx. weights in kilograms					
Slate	Weight per slate	Per m ² laid at 90 mm lap	Per m ² laid at 100 mm lap	Per m ² laid at 110 mm lap	Per m ² laid at 150 mm lap
600 x 300 mm	1.5	19.65	20.10	20.40	22.20
500 x 242 mm	1.01	N/A	21.1	21.6	N/A

Ventilation

As stated in the Building Regulations, roof constructions must be sufficiently ventilated in order to avoid harmful condensation of the insulation, timber, metal parts, etc. The Building Regulations divide roofs into the following categories with corresponding ventilation requirements.

- Standard duo pitch roof
- Mono pitch/lean-to roof
- Non-standard duo pitch roof
- Duo pitch roof with cathedral ceiling, and
- Mansard roof.

Find the ventilation requirements for your roof below:

Standard Duo Pitch Roof

Limitations

Roof pitches 15°-35° and eaves-to-eaves distance less than 10 m. Where the roof pitch is 25° or less, please contact your local merchant or Swisspearl before specifying slate vents.

Requirement
10,000 mm²/m run of eaves is required at eaves or low level, corresponding to a continuous 10 mm opening.

Vent Solutions

For low-level solutions, select either and over fascia or soffit solution

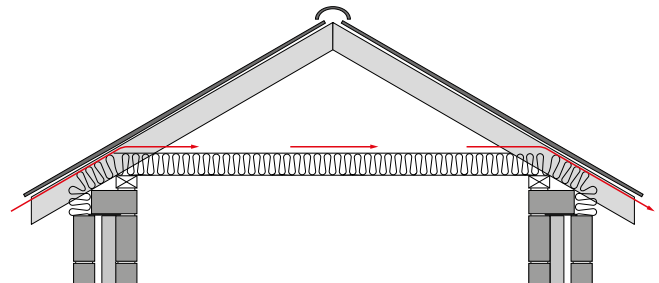

Mono-Pitch/Lean-To Roof

Limitations

Where the roof pitch is 25° or less, please contact your builders merchant/slate supplier and refer to the ventilation manufacturer's literature before specifying slate vents.

Requirement

10,000 mm²/m run of eaves is required at eaves or low level, corresponding to a continuous 10 mm opening.
5,000 mm²/m run of ridge or abutment is required at ridge, abutment or high level. This corresponds to a continuous 5 mm opening.

Vent Solutions

For low level ventilation, select either over fascia or soffit, as described for standard duo pitch roof. For high level ventilation, select either slate ventilator or ridge or abutment solution.

Non-Standard Duo Pitch Roof

Limitations

Roof pitches greater than 35° or eaves-to-eaves distance greater than 10 m. In certain circumstances, even where pitch and size limitations do not apply, the provision of eaves-to-eaves ventilation alone may not be adequate. By incorporating high level ventilation, the effectiveness of natural ventilation of the roof space is increased.

Requirement

10,000 mm²/m run of eaves is required at eaves or low level. This is equivalent to a continuous 10 mm opening.
5,000 mm²/m run of ridge is required at ridge or high level. This corresponds to a continuous 5 mm opening.

Vent Solutions

For low level ventilation, select either over fascia, soffit or slate ventilator solution, as described for standard duo pitch roof. For high level ventilation, select either slate ventilator or ridge solution.

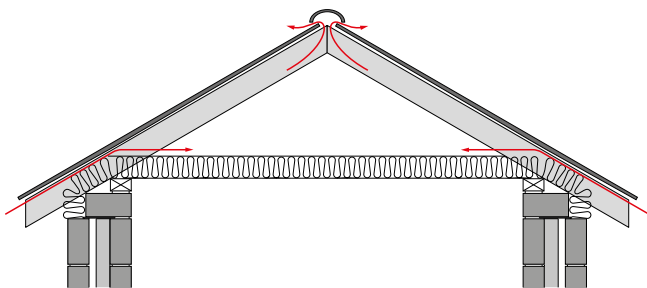

The roof space and/or batten cavity must be ventilated in accordance with the latest versions of Technical Guidance Document L and Technical Guidance Document F. TGD L gives guidance on the application of design principles. Fibre cement slates should be considered an impermeable external covering. In cold roof construction the loft space must always be ventilated. If an LR "breather" underlay is used the batten space* must also be ventilated.

*see page 17 for more information regarding counter battens

Duo Pitch Roof with Cathedral Ceiling

Limitations

All roof pitches with insulation following the line of the rafters, incl. pitches with a void at the apex and/or the eaves. Please note that if there is no void at the apex, slate ventilators cannot be used to provide high level ventilation.

Requirement

25,000 mm²/m run of eaves is required at eaves or low level, corresponding to a continuous 25 mm opening. 5,000 mm²/m run of ridge is required at ridge or high level, corresponding to a continuous 5 mm opening. Free airspace between the back of the slates and the underlay must be at least 50 mm.

Vent Solutions

For low level ventilation, select either over fascia or soffit solution. For high level ventilation, select either slate ventilator or ridge solution, as described for non standard duo pitch roof.

Mansard Roof

Limitations

All roof pitches with insulation following the line of the rafters, incl. pitches with a void at the apex and/or the eaves. Please note that if there is no void at the apex, slate ventilators cannot be used to provide high level ventilation.

Requirement

25,000 mm²/m run of eaves is required at eaves or low level, corresponding to a continuous 25 mm opening. 5,000 mm²/m run of ridge is required at ridge or high level, corresponding to a continuous 5 mm opening. Free airspace between the back of the slates and the underlay must be at least 50 mm. The airspace is created by installing counterbattens.

Vent Solutions

For low level ventilation, select either over fascia or soffit solution, as described for the duo pitch roof with cathedral ceiling. For high level ventilation, select either slate ventilator or ridge solution, as described for duo pitch roof with cathedral ceiling.

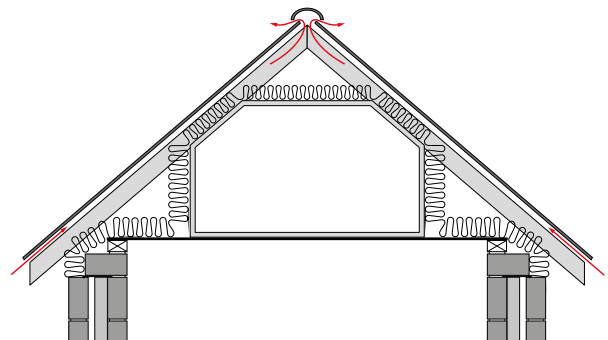

In warm roof construction with an HR underlay a ventilated void between the insulation and the underlay must be provided. If an LR "breather" underlay is used the underlay and the batten space* above must be ventilated, in addition a VCL (impermeable membrane) must be provided between the insulation and the internal finish. TGD F gives guidance on the ventilation requirements to prevent excessive condensation in a roof.

Underlay

A solid underlay such as boarding or decking provides added structural stability, especially for long roofs and roofs with low pitches. Furthermore, according to SR82, a roofing underlay, whether flexible or solid, has two functions:

1. The underlay acts as a barrier to prevent wind-driven rain, snow or dust from entering the roof space and transports any rainwater which may penetrate the joints of the slating safely away and into the roof drainage system
2. The underlay reduces suction on the slates generated by wind gust

SR82 recommends the following minimum head laps for roofing underlay:

Pitch	Not fully supported	Fully supported
Below 22.5°	225 mm	150 mm
22.5°-35°	150 mm	100 mm
35° and over	100 mm	75 mm

NOTE!

- **Swisspearl fibre cement slates are classed as an impermeable roof covering. When installed with vapour permeable underlays (LR), counterbattens must be used. The 50 mm counterbatten cavity is ventilated with 25,000 mm²/m ventilation at the eaves and 5,000 mm²/m on either side of the ridge or at high level.**
- Always apply counter battens, running from eaves to ridge, in order to lift slating battens clear of a solid underlay and its vapour-permeable membrane covering
- Locate side laps of flexible underlay over a rafter. Side laps must not be less than 100 mm.
- Where underlay is unsupported (i.e. draped over rafters), minimise the gap at the head laps resulting from tautness between the underlay sheets.
- Provide approximately 10-15 mm clearance between the underside of the battens and the underlay (measured at the mid-point of each drape), ensuring sufficient clearance to permit free drainage of moisture, but not so great as to permit contact with the underside of the slating when the underlay is subjected to wind uplift loads.
- Where underlay overlaps do not coincide with a batten, consider either including an extra batten to secure the overlap or increasing the overlap to coincide with the next batten.

Battens

The below table offers you maximum dimensions for rafter centres according to SR82.

	Rafter centres up to 400 mm	Rafter centres 400-600 mm
Battens	47x22 mm	47x35 mm
	50x25 mm	50x35 mm

One of the biggest issues with slate battens is under-sizing. To avoid this, there are clear tolerance limits for the minimum depth of the slate batten, which is +3 mm/-0 mm. Also, slate battens cannot be less than 25 mm deep and where the span between supports exceeds 600 mm, calculations must be completed to determine their correct dimensions for structural integrity.

All slate battens must conform to requirements set out in SR82 and must be checked prior to installation. The length of the battens must be minimum 1200 mm and supported by at least three rafters, trusses or walls. If the distance between any two rafter centres exceeds 400 mm, either insert an additional rafter to support the battens or apply battens capable of spanning 600 mm. The batten gauge can be calculated as follows:

$$\text{Batten gauge} = \frac{\text{Slate length} - \text{Head lap}}{2}$$

Counter Battens

Counter battens are battens that run from eaves to ridge. Please, follow the instructions below, when installing counter battens:

1. Ensure that the width of the counter batten is the same as the supporting rafter and that it, where fully supported, has a depth not less than 22 mm.
2. Fix counter battens at centres coinciding with rafters/trusses, marking positions of latter at top edges and eaves before laying underlay.
3. Fix counter battens through underlay into rafters/trusses at centres not more than 300 mm apart.
4. Where rigid thermal insulation is located on rafters, ensure that the required structural fixing of counter battens is achieved.

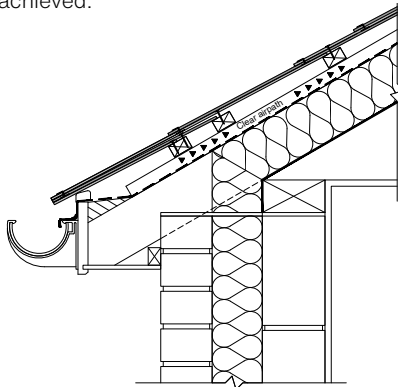

Fibre cement slate roof with LR underlay and ventilated counterbatten void.

Installing Battens

Please, follow the instructions below, when installing battens:

1. Fix battens in a straight, horizontal line, aligned on adjacent areas and fixed to each support, with splay fixing at joints.
2. Place only one joint in any group of four battens on any one support and ensure that each joint is square-cut and butted centrally on supports.
3. Add an extra batten where an unsecured lap in the underlay occurs between battens
4. When using headless fixings such as helical nails, make sure to comply with the manufacturer's recommendations as to the thickness of the members to be fixed and the adequacy of withdrawal resistance.
5. When applying sawn softwood, please comply with the requirements set out in SR82. Permissible characteristics and defects must not exceed the limits given in SR82.
6. Ensure that the moisture content does not exceed 22% at time of fixing.
7. Treating battens with preservative is not essential, but

should be considered where timber members are at risk of attack by wood-rotting fungi – i.e. where the moisture content of the battens is likely to remain above 20% for longer periods of time. Please, be aware of the risk of chemical attack by certain types of preservative treatments on certain roofing underlay, metal fittings and fasteners. Please, follow one of the following methods: CCA vacuum pressure or organic solvent double vacuum to British Wood Preserving and Damp Proofing Association Commodity Specification C8. Additional information on preservative treatment is provided by BS 5268 : Part 5.

Flashing & Weathering

When installing Swisspearl slates, please ensure to flash the slates with equally durable metals, preferably lead or copper sheets, fixed in compliance with the recommendations given by The Lead Sheet Association or The Copper Development Association.

In order to avoid undesired patination of your roof as a consequence of lead carbonate caused by the combination of lead sheets and rain water, all lead elements should be treated with patination oil before the rain occurs and not later than the day of fixing. The patination oil covers the lead elements with a semi-permeable protective membrane which permits moisture and atmospheric gases to percolate gradually through to the surface of the sheet, allowing the formation of an adherent natural grey patina over a period of time. Swisspearl recommend the application of pre-coated or painted aluminium flashings to avoid run-off staining of the slates, which may occur when applying untreated aluminium flashings.

NOTE! In the event of lead staining, any attempts to remove such staining from the slates may void the warranty of the product.

Installing Slates

Please, follow the instructions below, when installing slates:

Use only:

Copper, stainless steel or siliconised bronze nails that comply with the requirements of BS 1202-2.

Galvanised nails are not permitted.

- Length: 30 mm
- Shank diameter: 2.65 mm

Copper crampions;

- Stem length: 19 mm
- Stem diameter: 2 mm
- Base thickness: 0.5 mm
- Base diameter: 19 mm

1. Fix each layer of slates with tails aligned to a half-lap bond, ensuring no more than 4 mm gaps between the slates.
2. Fix extra-wide slates at the ends of the layer to keep the bond, leaving cut slates as large as possible. Ensure that the cut slates are not less than half the width of a full slate.
3. Fix slates with two copper nails and one copper crampion. Ensure that slates wider than slate-and-a-third are fixed with three nails and two crampions.
4. Drill all additional holes on site before fixing.

Eaves

Apply a triangular tilting fillet at the eaves to fully support the underlay and prevent moisture from developing behind the fascia.

Install the tilting fillet as follows:

1. Apply materials such as:
 - a. continuous timber, shaped to suit (not recommended where over-fascia ventilation is proposed).
 - b. 6 mm board material (such as exterior grade plywood) or plastic underlay support tray.
2. Ensure that the tilting fillet falls outwards to the gutter by approx. 10°.
3. Be aware that placing a batten beneath the underlay does not provide the necessary eaves support.
4. Raise the tails of under eaves and eaves slates slightly above the plane of the battens to ensure that finished slates fit correctly.
5. Tilt the slates 8-15 mm above the plane of the battens.

Underlay

Eaves Support

In order to prevent water development at the eaves and to ensure that the surface moisture is securely discharged into the gutter, it is important to support the roofing underlay at the eaves. Please, follow the instruction in BRE Defect Action Sheet 9, published by the Building Research Establishment Housing Defects Prevention Unit to ensure sufficient underlay support.

Eaves Reinforcement

Some underlay materials are not resistant towards UV degradation, e.g. Type 1F felt to BS 747 or IS 36. In such

circumstance, a UV-resistant material such as Type 5U felt or an underlay support tray can be used as eaves reinforcement. Install the eaves reinforcement material between the eaves support and the underlay. It is important to ensure compatibility between the materials used as reinforcement and the underlay.

Eaves Batten

For all slates apply that the positioning of the first batten depends on the length of slate and head lap specified.

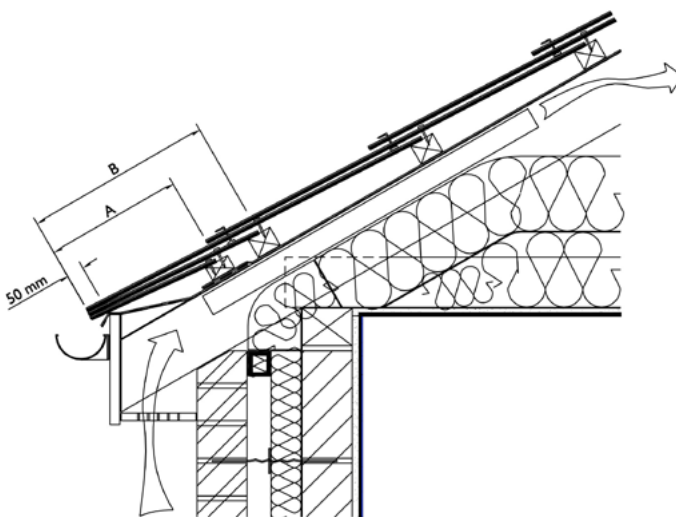

Standard eaves with soffit ventilation.

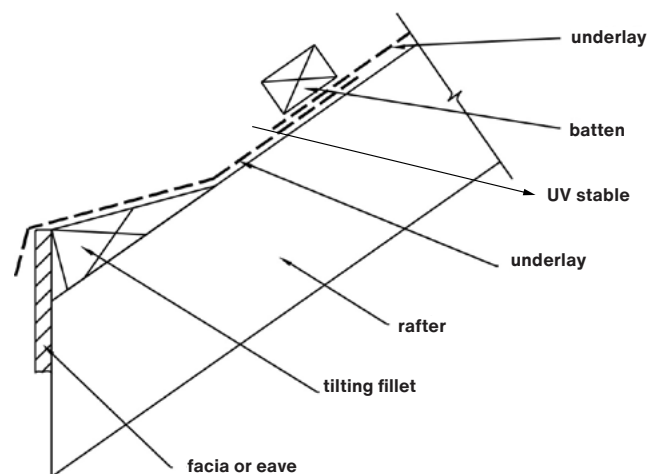

Eaves: Structure and underlay.

Slates

Eaves Slate Layers

When installing the slates, two under eaves layers are installed:

1. The first under eaves layer:
 - a. equal in length to the gauge
 - b. head nailed
 - c. supports the lowest crampion and stabilises the eaves
2. The second under eaves layer:
 - a. equal in length to the gauge plus the head lap
 - b. centre-nailed
 - c. laid in a broken bond over the first under eaves layer.

In order to cut as few slates as possible, the under eaves slates can be cut from one full slate as the sum of the lengths of the under eaves layers is equivalent to the head lap plus twice the gauge.

Turn the under eaves slate “upside down”, allowing the riven or dressed edge of each slate to narrow in towards the other before being head nailed. This installation method creates a strong, sharp line at the eaves. Both the under eaves layers and the first full layer of slates must overhang the gutter by approx. 50 mm, measured horizontally from the face of the fascia.

Ventilation Accessories

Ventilation of the eaves can be established by means of soffit or over-fascia ventilators.

Soffit ventilators:

- Ventilation: Insert soffit grilles into the soffit, running parallel to the eaves, to achieve the required airflow rating.
- Underlay support: Fix an underlay support tray or a continuous timber tilting fillet to the rafters to provide continuous support for underlay at eaves and to prevent water development.
- Ventilator trays: Fix a rafter tray to the rafter to ensure free air passage between the soffit and the roof space or the ventilation space between the membrane and the slates as required by the membrane choice. Place insulation over wall plate.
- When using a timber tilting fillet, fix a strip of IS 36, Type 5U felt or a similar durable underlay as eaves reinforcement to under lap first full layer of roof underlay.
- Dress roof underlay and eaves reinforcement down into gutter.
- Fix eaves slates with tails projecting 50 mm over the gutter or to the centre of the gutter, whichever dimension is the lowest.
- Ensure that the first under eaves slate layer corresponds in length to the batten gauge.
- Ensure that the second under eaves slate layer corresponds in length to the batten gauge plus the slate head lap.

Sizing Under Eaves slate Layers			
Slate size (mm)	Lap (mm)	1st undereaves slate length (mm) A	2nd undereaves slate length (mm) B
600 x 300	110	245	355
600 x 300	100	250	350
600 x 300	90	255	345
500 x 242	100	200	300
500 x 242	90	205	295

Verge

Roofs are often exposed to high wind pressure sometimes causing spiraling turbulence around the verges. In order to avoid damage to your roof, it is important to adequately secure all edge slates. Verge slates may be finished either with an under cloak, mortar-pointed system or a dry-fixed verge.

Cavity

Close off the top of the cavity wall construction with a fibre-cement cavity closer strip.

Underlay

When installing the roofing underlay, ensure that:

- All underlays extends over the outer edge of any verge.
- underlay for dry verge lap onto the outer leaf of the wall, or with overhanging verge, onto the flying rafter and extends approx. 20 mm beyond the bargeboard.
- Underlay used with overhanging verges to be under cloak and pointed lap under the under cloak and extends approx. 20 mm beyond the bargeboard or the face of the wall.

Battens

When installing the battens, ensure that they overlap the wall or under cloak by not less than 50 mm. With overhang verges, the batten end must be securely supported by a flying rafter. Note that all slate batten ends must be mechanically secured.

Slates

Dry-Fixed Verges

In Ireland, one of the most common verges applied is the plain overhanging verge, i.e. the slates overhang the bargeboard or gable by between 30 mm and 50 mm. Using a dry-fixed verge trim for this purpose can easily and significantly improve the performance of the roof.

Trim designs:

- One for overhanging verges
- One for flush verges
- One for refurbishment work or fitting after completed slating

Fixing trims:

1. Bed the cavity closer of the Swisspearl slate on a mortar mixture level with the underside of the slate battens.
2. Carry the roof underlay over the cavity closer, across the verge ladder frame and project 20 mm over the top of the bargeboard.
3. Carry battens to back of barge board.
4. Ensure an overhang of the finished verge.
5. Ensure that trims are overlapped by 50 mm at joints.
6. Ensure that trims are fixed into each batten with a 20 mm clout nail.

When installing Swisspearl slates begin alternate layers at the verges with a cut double-width slate or a cut slate.

Fixing of slates:

- Fix slates wider than one-and-one-third times the specified slate width with three nails and two crampions.

As previously mentioned, never apply cut slates less than half the width of a full slate.

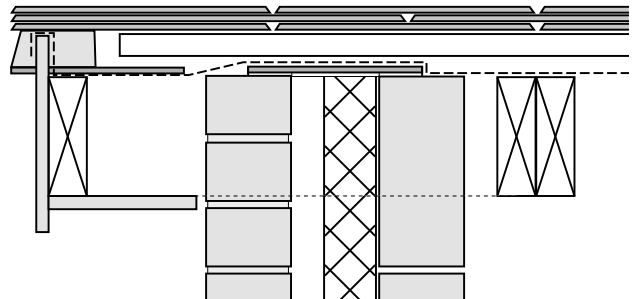

7. Then slide slates into the preformed channel and fix.
8. Lay standard slates and extra-wide slates at ends of alternate layers.
9. The result is a perfectly straight and secure verge.

Pointed Verge

Please, install pointed verges as described below:

- Verge overhang: >38 mm, <50 mm.
- Place under cloaking slate face down.
- On overhanging verge, nail the under cloak.
- On flush verges, bed the under cloak in mortar on the wall.
- Provide approx. 75 mm mortar width, avoiding direct contact with the batten ends.
- Finish the edge neatly.
- Where later pointing of the bedding is probable, the risk of cracking and separation can be avoided by applying the bedding, making allowance for a substantial later insertion of mortar for finishing and pointing.
- Dampen the mortar bed prior to pointing.

Ridge

When installing Swisspearl slates, Swisspearl recommend the application of ridge cappings of fibre-cement, clay or concrete.

Underlay

Duo-pitch roofs not requiring ridge ventilation:

Carry underlay on one slope of the roof over the ridge to overlap the underlay on the other slope by not less than 225 mm.

Mono-pitch roofs not requiring ridge ventilation:

Carry underlay over the mono ridge to extend vertically by not less than 100 mm.

Ridges requiring ventilation:

Cut underlay and turn upwards to form a continuous 5 mm gap on either side of the ridge board. Secure the turned-back felt by tacking to the back of the slating battens nearest to the ridge.

Battens

In order to achieve a neat and uniform finish towards the roof slope, it is possible to increase (never decrease) the head lap of the final layers of slates up to the ridge. Be aware that batten positions may need to be adjusted accordingly. Use slating battens or an extra-wide batten along each side of the ridge to easily position and fix both slates and dry-fix ridge cappings.

Slates

When installing slates up to the ridge ensure that:

- An approx. 10 mm gap remains between the slated surface on opposing slopes of the roof.
- The specified minimum head lap is provided in the area around the ridge – It may not always be possible to achieve this using full-length slates laid to standard gauge.
- The minimum head lap of the ridge capping over the penultimate layer of slates is achieved – this can be done by installing shortened slates in the top two layers on either side of the ridge.
- Areas of severe exposure are additionally secured e.g. by a continuous, UV-resistant material such as a dpc strip placed over the apex as a soaker between the last two slate layers on each slope.

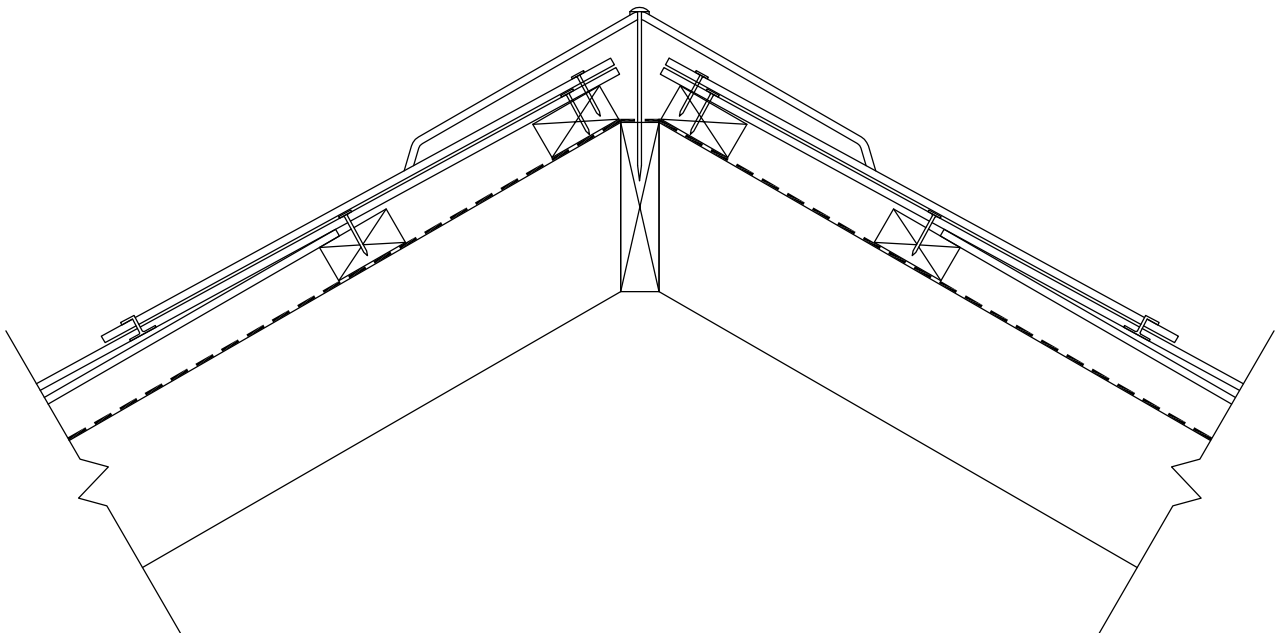

Ridge Cappings

Dry-fixed Ridge

When installing dry-fix ridge cappings, please follow the below procedure:

1. Place and fix the top slating battens or additional battens, facilitating mechanical fixing of the ridge cappings.
2. Place the cappings with the internal spigot joints facing towards or the external socket joints facing away from the wind.
3. Place top layer of the underlay from one side of the ridge over the apex to overlap underlay at the other side by at least 225 mm.
4. Place and fix top slating battens to suit fixing of ridge cappings: apply double or extra-wide battens.
5. Alternatively, you can secure the ridge cappings by fixing a long drive screw through the apex or crown of the capping into the ridge board. This fixing method is acceptable, provided that:
 - Fix ridge cappings to slating battens with 50 mm no. 10 gauge brass or stainless steel screws with washers and caps. One fixing on each side of capping positioned 50 mm up from the edge of the capping wing and centred on the socket.
 - Cappings are predrilled with holes oversized by 2 mm prior to fixing, and
 - Drive screws are not over-nailed, so as to fracture the capping.
6. Ensure that end ridge cappings are always full length units.
7. Finish the slating with a head-nailed short layer of slates to maintain the gauge.

Selecting Correct Ridge Capping	
Roof Pitch	Fibre Cement Ridge Capping
25°	135°
30°	120°
35°	105°
40°	90°
45°	90°

Hip

The true angle of the hip pitch is always lower than the rafter pitch, making the hip more sensitive towards exposure of wind and wind-driven rain. When roofing with Swisspearl slates, Swisspearl recommend the use of fibre-cement or clay hip cappings. The exposure of the site combined with the angle of the roof pitch determines whether specifying a close-mitred hip should be considered.

Underlay

When installing the underlay of a roof slope neighbouring a hip, ensure that the underlay:

- Overlaps the line of the hip.
- Is carried across the neighbouring roof slope by minimum 150 mm, and
- That an additional minimum 600 mm underlay is rolled out along the line of the hip – from eaves to ridge.

Battens

Install extra-wide hip or raking battens on roof slopes neighbouring a hip. Ensure that these battens are the same height as the slating battens and fixed to either side of the hip – from eaves to ridge.

These hip battens are to receive the dry-fix hip cappings and to serve as extra support of the cut slates making up the edge of the roof. The hip battens can also serve as fixing point for the slating battens, cut to the rake of the hip. Thus, the slating battens can be nailed directly into the hip battens from their lower side, i.e. closest to the eaves.

Slates

When installing roof slopes neighbouring a hip and hip cappings are to be used, ensure to rake-cut slates to the hip line with an approx. 10 mm gap between the two slate layers. Install double-blank slates, whenever the width of the tapered head of a standard slate is below 50 mm.

NOTE! Never apply small, triangular-cut slates.

Cappings

Dry-fixed Hip

When installing dry-fix hip cappings, please follow the below procedure:

1. Place the hip cappings with the internal spigot joints facing upslope or the external socket joints facing downslope.
2. Place the underlay over the hip, ensuring minimum a 150 mm overlay.
3. Place a 600 mm continuous underlay strip from eaves to ridge over the main roof underlay.
4. Place and fix hip slating battens running from eaves to ridge on either side of the hip line to suit fixing of hip cappings: apply double or extra-wide battens.
5. Cut slates in the relevant sizes and fix closely at roof slope junctions.
6. Fix metal saddle under hip and ridge cappings junctions.
7. Alternatively, you can secure the hip cappings by fixing a long drive screw through the apex or crown of the capping into the ridge board. This alternative fixing method is acceptable, provided that:
 - Fix hip cappings to slating battens with 50 mm no. 10 gauge brass or stainless steel screws with Sela M6 washers and caps. One fixing on each side of capping positioned 50 mm up from the edge of the capping wing and centred on the socket.
 - Cappings are predrilled with holes oversized by 2 mm prior to fixing, and the drive screws are not over-nailed, so as to fracture the capping.
 - In junctions between a ridge and cappings, cut to a close mitre.
 - Underlap the junction with a concealed metal flashing saddle.
 - After fixing the cappings, trim the underlapping metal flashing saddle.
 - Fit a bead of butyl rubber tape in the mitre joints.
8. Neatly cut first hip capping in order to align with eaves.
9. Ensure that end hip cappings are always full length units.

Close-Mitred Hips

Close-mitred hips are applied only when the roof pitch exceeds 30°.

Install the close-mitred as follows:

1. Rake cut slates on opposite roof slopes in order to create a close mitre at the hip.
2. Ensure that the width of each tapered slate head is minimum 50 mm.
3. Place cut soakers with each layer, extended approx. 150 mm on each side of the hip line.
4. Ensure a minimum soaker length as follows:
Soaker length = raking gauge + head lap + 30 mm
NOTE! For sites with severe exposure or with roof pitches exceeding 45°, external tail fittings such as slate hooks or screws with washers and caps may be necessary to secure the roof against high wind loads.

Selecting Correct Hip Capping		
Roof Pitch	Hip Pitch	Fibre-Cement Hip Capping Required
25°	18.2°	145°
30°	22.2°	135°
35°	26.3°	135°
40°	30.7°	120°
45°	35.3°	120°
60°	50.8°	90°

Valley

One of the areas of a roof which is highly exposed to wind and wind-driven rain is the valley. Therefore, you have to carefully consider the design and construction of the roof before you start building. The following items are important to consider:

- Expected exposure to wind-driven rain
- Size and pitch of roof slopes draining into valley gutter
- Length and required capacity of valley gutter
- Height of valley lining boards compared to slating battens
- Material used for valley gutter
- Jointing of valley gutter

The design possibilities of valley gutters are many, e.g. as proprietary preformed valley gutters or as close-mitred valleys, etc. However, Swisspearl recommend the use of open valleys with sheet metal linings and thus, this Installation Manual describes only this method.

Structure

The true angle of the valley pitch is always lower than that of the neighbouring roof slopes. Install the valley as follows:

1. Ensure a minimum open width of the gutter of 125 mm, by extending the valley boards at least 225 mm to each side of the centre of the valley.
2. Place the top of the triangular tilting fillet on each side of the gutter approx. in level with the tops of the battens.
3. Ensure that the triangular tilting fillets are placed 150 mm from the centre of the valley - measured along the slope.
4. Ensure that valley boards are at least 19 mm and recessed in order for their tops to level with the rafter tops.
 - a. Cut-rafter roof: notch the tops of the rafters.
 - b. Pre-fabricated trussed-rafter roof: Do not reduce rafter depth! Cut valley boards into section and place them flush between the rafter tops, supported on bearers fixed to the sides of the rafters. Place a 4 mm flat sheet across the tops of the valley boards and rafters, providing a smooth surface to receive the metal lining.

NOTE! According to the SR82, valley boards may be supported on the tops of the rafters, provided that the length of the valley gutter (measured along the valley slope) does not exceed 6 m.

Water Run-off

The expected water run-off of a roof is important to consider, when designing the roof and the valleys hereof. The assumed design maximum rainfall rate is 225 mm/h/m². Please, consider the following:

- Where two roof slopes with different pitches meet at a valley, carefully detail the valley gutter substrate and lining, preventing water run-off from the steeper slope from surcharging the gutter and spilling onto the underlay of the lower slope.
- Where length of valley gutter (measured along the valley slope) exceeds 6 m and roof pitch is <30°, widen the valley gutter to avoid surcharging the lower end during heavy rain or wind.

For further guidance on rainfall and expected discharge, please consult BS EN 12056-3:2000.

Roof Pitch	True Pitch of Valley (Between Roofs of Equal Pitch Meeting at a Right Angle)
25°	18.2°
30°	22.2°
35°	26.3°
40°	30.7°
45°	35.3°
60°	50.8°

Underlay

Place the roof slope underlay with a 25 mm overhang of the tilting piece on the side of the valley board and dress into the valley gutter.

NOTE! If the risk of adhesion exists, e.g. when using bituminous felts, do not place metal valley materials directly onto the underlay. Adhesion may cause reduced performance of the valley material, when this is cooled down following periods of warm weather.

Battens

Ensure that batten ends are fully supported.

Slates

When installing slates neighbouring the valleys, please follow the below instructions:

1. Apply double-blank slates on both sides of a valley.
2. Place slates into the valley.
3. Rake-cut slates to overhang the tilting fillet, providing the required open channel.
4. Ensure a minimum slate tail width of 100 mm.
5. Cut extra-wide slates neatly and fix centred on valley, ensuring a minimum gap of 125 mm.

NOTE! Do not bed slates in mortar.

Sheet metal valley

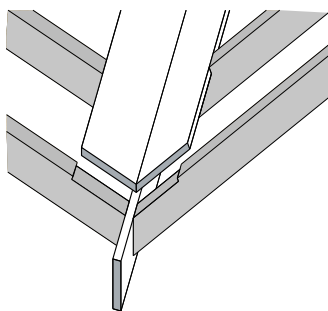
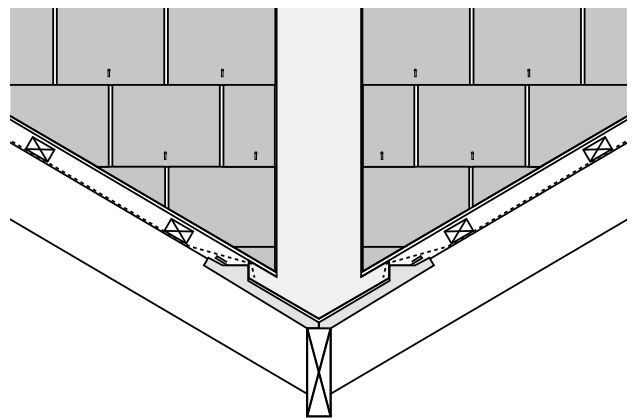

Cut roofs

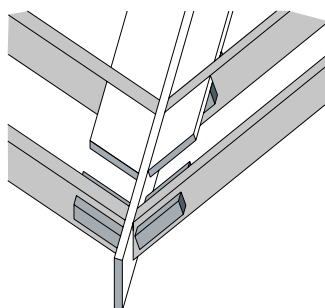

Trussed-rafter roofs

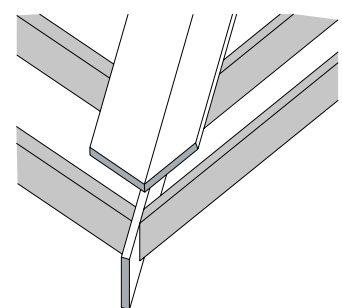

Small roofs

Abutments

Abutments

Areas where the plane roof slope is interrupted, e.g. by a wall, chimney or dormer window, are particularly exposed to water development. Therefore, it is important to take special precautions around these areas. Usually, such areas are weathered with flexible metal flashing, e.g. lead.

Structure

When installing slates around abutments, please follow the below instructions:

1. Leave a 50 mm gap between masonry walls and timber rafters at side abutments.
2. Design tilting fillets applied at back gutter the same way as tilting fillets at eaves.

Underlay

When installing underlay around abutments, please follow the below instructions:

1. Carry underlay up the vertical plan of the abutment and place by approx. 100 mm at top and side abutments.
2. When possible, secure and seal underlay, creating a weather tight junction and preventing underlay from sagging over time.
3. Support underlay at back gutters (as with eaves), ensuring a minimum overlap of the back gutter material of 100 mm.
4. Prevent the development of water on the underlay.

Battens

At top edges, place battens allowing an apron flashing to overlap the top slate layer(s), thereby maintaining the required head lap. At side abutments, place battens 10-25 mm back from the face of the abutment and ensure sufficient support of the battens.

Slates

When installing the slates around abutments, please follow the below instructions:

1. Apply cut slates with a minimum width of half the width of a full slate.
2. Maintain the slate head lap by the flashing at top abutments.
3. Carry slates to 10-15 mm of the wall, preventing lead flashings from forming a cavity allowing water development.
4. Head-nail the top layer of slates into the batten without drilling the slates below.
5. When forming a back gutter, place slates similarly to the eaves. However, length and number of under eaves layers depend on the slate layer on the neighbouring roofing area.
6. When installation of two under eaves layers is not possible, drill slate tails and tie with copper wire or hook fix.

Back Abutment

Back abutments or back gutters must be open or tapering gutters. Weathering of such back abutments or back gutters can be achieved by a lead sheet either bossed or cut and lead welded to the appropriate profile and protected at the wall by a cover flashing.

Weathering Abutments

Top Abutment

Weathering of top abutments can be achieved either by a one-piece metal apron or by a combined apron-and-cover flashing. Please, follow the below instruction, when weathering the top abutment:

1. Ensure that the apron is clipped. The distance between restraining clips depends upon site exposure.
2. Turn underlay minimum 100 mm up from abutment.
3. Finish slating with a head nailed slate layer in order to maintain gauge.
4. Fix slates close to abutment to allow installation of a metal apron flashing, ensuring a weather tight junction.

Side Abutment

Weathering side abutments can be achieved by a combination of interleaved soakers and a cover flashing. Please, follow the below instructions, when weathering the side abutment:

1. Place a soaker between each slate layer and head nail to batten.
2. Ensure a soaker length as follows:

Soaker length = gauge + head lap + 25-30 mm

3. Turn underlay minimum 100 mm up from abutment.
4. Cut slates as required and interleave with metal soakers.
5. Fix soakers by turning down over the head of each batten.
6. Fix slates close to abutment to allow installation of a metal apron flashing, ensuring a weather tight junction.

NOTE! Where there is a risk of water penetration of the soakers, an alternative method of weathering is to construct either an open or hidden secret gutter.

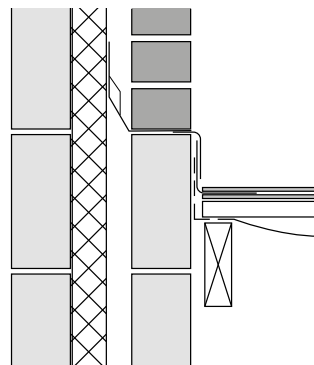

Advice

Swisspearl recommend that any cover flashing, rendering or painting of areas projecting above a slated roof be completed before roofing begins to avoid damage to or staining of the slates. Clean the roofing underlay of any mortar droppings before slating begins.

Maintenance

In order to ensure a long lifespan of your roof, please inspect the roof at least twice a year; end-autumn after leaf fall, and late-spring, after heavy rain and snow fall is over – and otherwise, when the weather conditions have been exceptional.

Inspection Guide

- ✓ Ensure that there is no evidence of water penetration in internal roof space.
- ✓ Clear any blocking of ventilators, especially near eaves, to avoid condensation.
- ✓ Clear eaves gutters of leaves and other plants.
Ensure that the joints in the gutters are tight - metal-lined valley gutters should be examined for deterioration, creep, cracking etc.
- ✓ Ensure free-flow of water to outlets.
- ✓ Remove growth of algae, mosses and lichens by gently spraying the roof with an appropriate herbicide.
The use of a pressure washer is not recommended when cleaning fibre cement slates.
- ✓ Examine the ridges and hip cappings and replace, bed and re-point where needed.
- ✓ Examine metal flashings and pointings at abutments.
- ✓ Examine the roof for damaged, slipped or missing slates – if several slates have slipped, the entire roof should be examined by a professional.

NOTE! Never walk on a slated roof as this does not provide a safe and non-skid surface which may lead to a fall causing serious injury and may also damage the slates.

Replacing Damaged Slates

If, during the inspection of your roof, you encounter any damaged slates, you need to evaluate the degree of the damage; is it a minor damage such as a chipped corner or a more severe damage? More severe damages to the slates are important to repair or replace as the weathering function of the roof might be affected.

Unfortunately, the installation method applied when roofing with slates does not allow you to easily remove one slate and replace this by a new one. To ensure proper and sustainable replacement of the damaged slates, follow the below procedure:

You will need the following tools:

- Hammer
- “Slater’s ripper”
- Stainless steel hook
- Copper nails (if more slates are to be replaced).

Do as follows:

1. Place the “slater’s ripper” underneath the damaged slate.
2. Bend up the crampion stems in the area around the damaged slate.
3. Cut or pull out the nails one by one, by placing the “slater’s ripper” around the shank of a nail. Then hammer downward on the upstand handle of the ripper, parallel to the pitch of the slope.
4. Carefully remove the slate as well as any small pieces of slate and nail.
5. Insert the stainless steel hook into the batten above the head of the slate. The length of the stainless steel hook must be length of head lap + 10 mm.
6. Bend the hook back slightly.
7. Use the “slater’s ripper” to carefully lift the existing slates lying over the head and concealed margin of the new slate.
8. Slide in the new slate with its head resting on a batten.
9. Tighten the hook back into position, by sliding the slate down into the hook.

The replaced slate relies solely on the hook, but the surrounding well-fixed slates help to prevent movement to the sides and upwards. If you need to replace an area of damaged slates, carefully remove the slates in a “V”-formation with the damaged slate as the base.

General Information

Service

If you have any questions regarding Swisspearl Berona, Berona Xxtra, Berona Stonedged & Berona Structured slates, our well-trained staff will be ready to assist you with advice and guidance.

Warranty

Warranty conditions can be commissioned at your nearest Swisspearl office.

Disclaimer

The information contained in this publication and otherwise supplied to users of Swisspearl's products is based on Swisspearl's general experience, best knowledge and belief. However, because of factors that fall beyond Swisspearl's knowledge and control, which can affect the use of the products, no warranty is given or implied with respect to such information.

Swisspearl's policy is one of continuous improvement. Swisspearl therefore reserve the right to alter specifications at any time and without notice.

Colours and textures may vary according to light and weather conditions. Owing to this and limitations of the printing process, colours in this brochure may vary.

Please, ensure that you have the latest version of this publication by checking that the publication date corresponds with the downloadable version from our website swisspearl.com. In case of doubt, please contact your local Swisspearl representative.

About Swisspearl

Swisspearl is one of the leading European manufacturers of fibre cement building products. Our products and solutions add exciting new design opportunities for moulding attractive, durable settings for people's lives. But Swisspearl is more than mere products. We also help make all kinds of design and construction projects easier as well as more profitable, inspiring and effective. And for us, all construction also involves building relations with people, making your day better, and helping you make the day better for others.



Swisspearl Ireland Ltd

Unit 6 Northwest Business Park
Ballycoolin
Dublin D15 WY6X
Ireland
+353 1 905 8300
info@ie.swisspearl.com

swisspearl.com